

**PARTS LIST: BB-FD006-BK BB-FD006-SS**

1	3.5in Bull Bar	4	10-1.5mm x 35mm Hex Bolts
1	20" LED Bar Style Light	8	10mm x 27mm OD x 3 mm Flat Washers
1	Driver/left Frame Bracket	4	10-1.5mm Nylon Lock Nuts
1	Passenger/Right Frame Bracket	4	8-1.25mm x 35mm Hex Bolts
1	Driver/left Tube Bracket	2	8-1.25mm x 16mm Hex Bolts
1	Passenger/Right Tube Bracket	2	8mm x 24mm x 2mm Flat Washers
2	Skid Plate Mounting Brackets	4	8mm x 22mm x 2mm Flat Washers
4	12-1.75mm x 45mm Hex Bolts	6	8mm Lock Washers
4	12mm x 37mm OD x 3.5mm Flat Washers		
4	12mm Lock Washers		

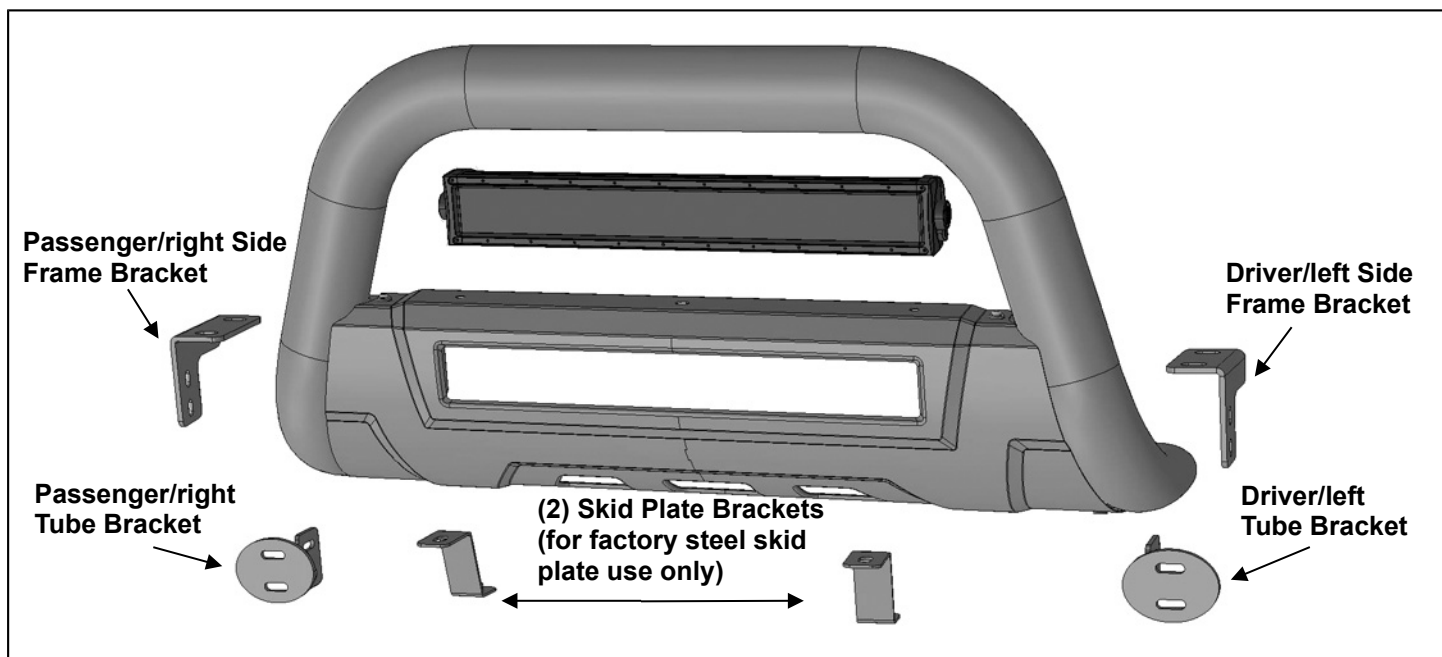

**PROCEDURE:**

**REMOVE CONTENTS FROM BOX AND VERIFY ALL PARTS ARE PRESENT. READ INSTRUCTIONS CAREFULLY. CUTTING MAY BE REQUIRED. INSTALLATION MAY INTERFERE WITH FRONT MOUNTED SENSORS.**

1. Start installation from under the front of the vehicle.
2. Determine if the vehicle is equipped with tow hooks. **IMPORTANT:** Tow hooks cannot be reinstalled with the Bull Bar.

**Tow Hook equipped vehicles:**

- a. Remove the plastic cover attached to the tow hook, (**Figure 1**). Next, remove the tow hook from the bottom of the frame, (**Figures 2—4**). On models with steel skid plate, temporarily remove skid plate, (**Figure 3**).
- b. Proceed to **Step 3**.

**Vehicles without tow hooks:**

- a. Cut out the lower section of the indented area in both sides of the plastic bumper insert to clear the Brackets as pictured, (**Figure 5**). **NOTE:** Hold the Frame Mounting Bracket up to the back of the bumper to determine area to remove to clear Bracket. **IMPORTANT:** Make several small cuts for best fit.
  - b. Insert the Mounting Brackets through the openings in the bumper to check for clearance around Brackets and hardware. Trim the plastic as required to clear the Brackets.
3. Select the driver/left Frame Mounting Bracket, (**Figure 6**). Hold the Bracket up to the bottom of the frame. Line up the holes in the Bracket with the (2) mounting bolt holes for the tow hook. Attach the Bracket to the

**3-1/2" OVAL BULL BAR  
19-20 FORD RANGER**

threaded holes in the frame with (2) 12mm x 45mm Hex bolts, (2) 12mm Lock Washers and (2) 12mm Flat Washers, (**Figures 6 & 7**). **IMPORTANT:** Models with steel skid plate, attach (1) Skid Plate Bracket to the rear mounting Bolt, (**Figure 6**). Leave hardware loose. Repeat this **Step** to attach the passenger/right Frame Bracket and Skid Plate Bracket if equipped.

4. Next, select the driver/left Tube Bracket, (**Figure 8**). Attach the Tube Bracket to the end of the Bull Bar with the included (2) 8mm x 35mm Hex Bolts, (2) 8mm Lock Washers and (2) 8mm Flat Washers, (**Figure 8**). Center the flange on the Bracket with the tube and snug but do not fully tighten hardware. Repeat this **Step** to attach the passenger/right Tube Bracket.
5. **Center LED Light Installation, (LED Light Bar Included):**
  - a. Attach the LED Light Bar to the back of the Bull Bar using the included (2) 8mm x 16mm Hex Bolts, (2) 8mm Lock Washers and (2) 8mm x 24mm Flat Washers, (**Figure 9**).
6. With assistance, hold the Bull Bar up in position on the outside of the Mounting Brackets. Attach the Bull Bar to the Brackets with (4) 10mm x 35mm Hex Bolts, (8) 10mm Flat Washers and (4) 10mm Nylon Lock Nuts, (**Figure 10 & 11**). Do not tighten hardware at this time.
7. Check the Bull Bar alignment with the vehicle and for clearance between the Bull Bar, light and the bumper. Adjust as required then fully tighten all hardware at this time.
8. Do periodic inspections to the installation to make sure that all hardware is secure and tight.

**To protect your investment**, wax this product after installing. Regular waxing is recommended to add a protective layer over the finish. Do not use any type of polish or wax that may contain abrasives that could damage the finish.

**For stainless steel:** Aluminum polish may be used to polish small scratches and scuffs on the finish. Mild soap may be used also to clean the Bull Bar.

**For gloss black finishes:** Mild soap may be used to clean the Bull Bar.

**Passenger/right Side Installation Pictured**

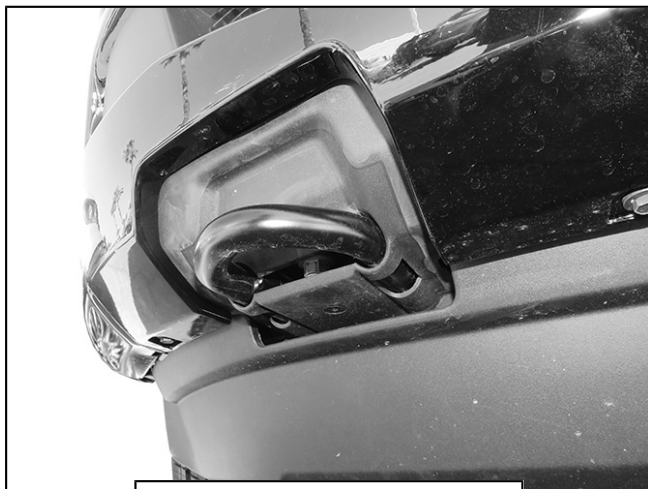

(Fig 1) Example of Tow hook

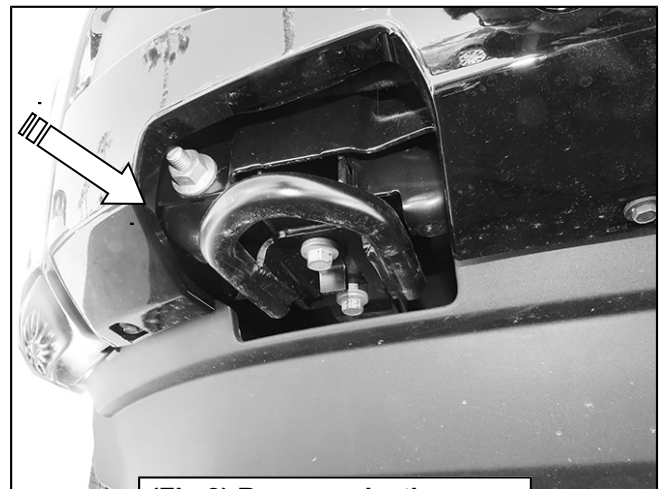

(Fig 2) Remove plastic cover surrounding tow hook

Driver/left Side Installation Pictured



(Fig 3) Models with steel skid plate, temporarily remove skid plate to access tow hooks

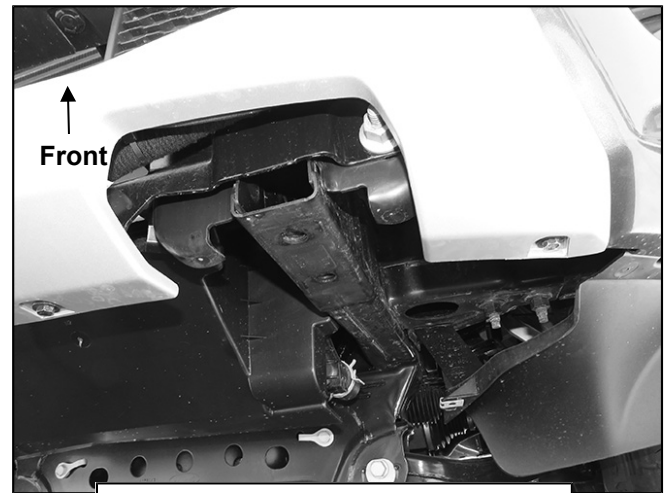

(Fig 4) Driver/left mounting location



(Fig 5) Models without tow hooks, cut openings in lower plastic cover to clear Brackets

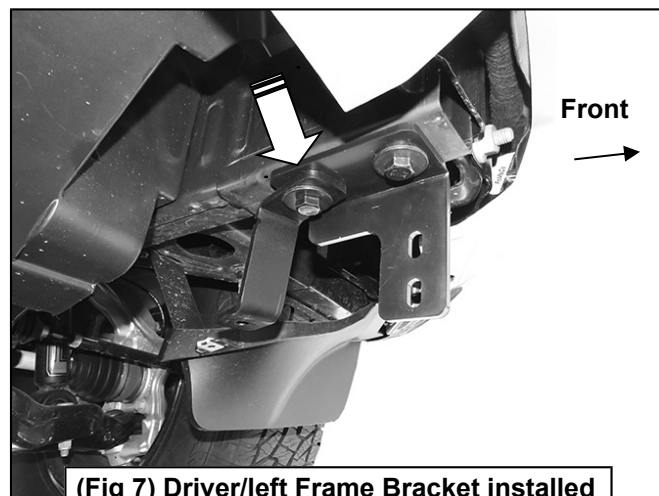

(Fig 7) Driver/left Frame Bracket installed with optional Skid Plate Bracket (arrow)

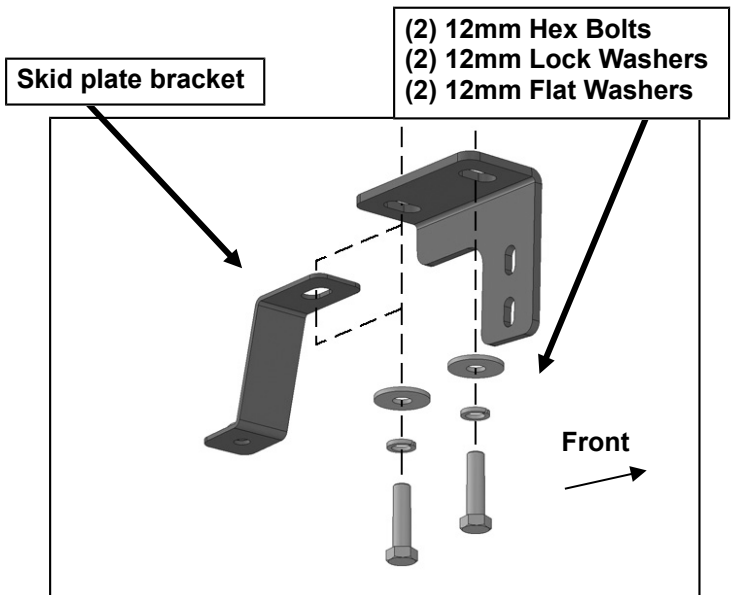

(Fig 6) Attach driver/left Frame Bracket to bottom of frame. Attach skid plate bracket to rear mounting bolt if equipped with steel skid plate

**3-1/2" OVAL BULL BAR  
19-20 FORD RANGER**

**Driver/left Side Installation Pictured**

