



IMPORTANT OWNER-OPERATOR INSTALLATION INSTRUCTIONS

M9001/20K MAGNUM SHANK XL 3/4" HOLES

APPLICATION FITS

- ORIGINAL 17 K SUPERHITCH
- 20K SUPERHITCH MAGNUM

PARTS INVENTORY-

1- DOUBLE SHANK 20K MAGNUM
BALL MOUNT XL WITH 3/4" HOLES.

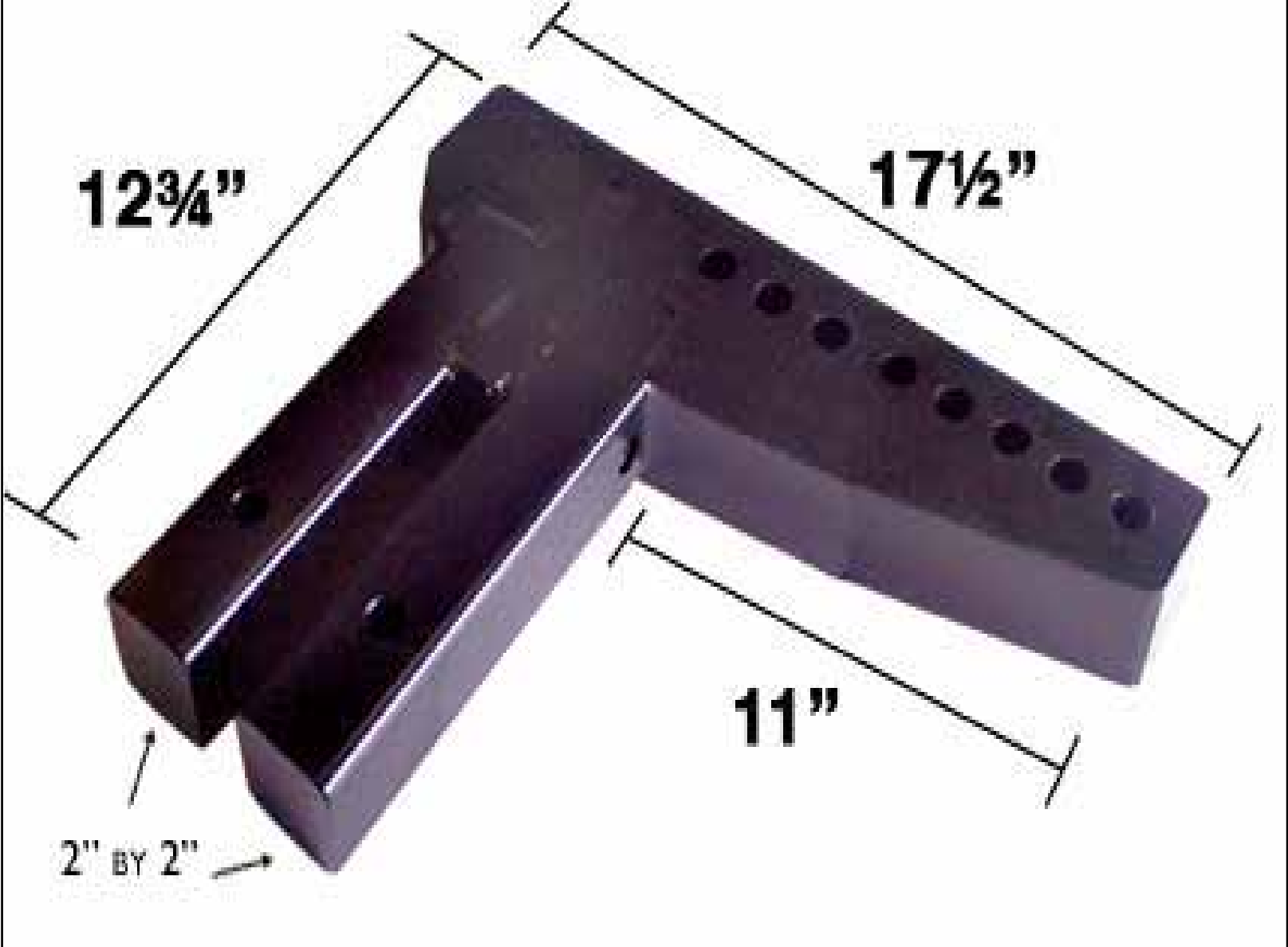

ALSO AVAILABLE:

M9001 20K BALL MOUNT XL ACCESSORIES-
(SOLD SEPERATELY)

M9002- MAGNUM PINTLE ADAPTER 20K

M9005- MAGNUM BALLMOUNT ADAPTER

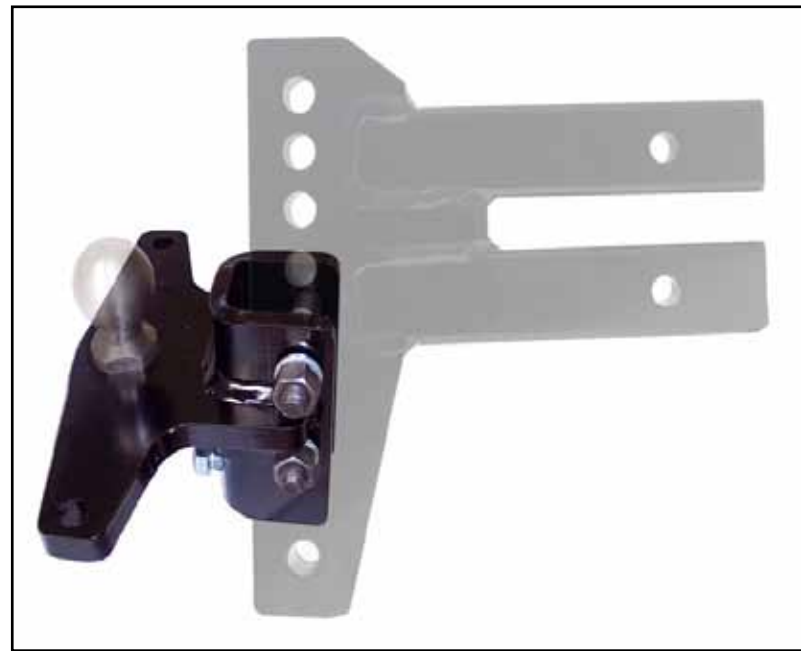

NOTE- TRANSPARENT PARTS DO NOT COME WITH LISTED PARTS.

INSTRUCTIONS FOR FINISH MAINTENANCE **OF TORKLIFT PRODUCTS**

POWDER COATED STEEL:

To keep your Torklift products looking good follow these guidelines. All steel powder coated Torklift products are sandblasted for maximum adhesion and use a high quality industrial urethane based powder coat. Due to the extreme, harsh, undercar environment that your Torklift products live in, (consistently sprayed with corrosive road chemicals such as salt, and road debris), **Torklift does not warranty the power coated finish.**

To minimize corrosion from these factors on powder coated steel products, Torklift recommends regularly cleaning and inspecting the powder coated surface and touching up any affected areas with an enamel or urethane based aerosol paint product. If there are any areas of surface rust, there are also aerosol spray rust converters available on the market that can be used as **a preparation to touch-up paint application.** These finish maintenance products are available at any automotive parts supplier.

POLISHED STAINLESS STEEL :

Torklift utilizes quality grade 304 stainless steel in our stainless steel polished products. 304 stainless steel is well known for its anti-corrosive properties. However, in some environments such as coastal regions or when coming in contact with some road chemicals, corrosion may occur.

For a quick clean simply use WD40 and a cloth rag. We also recommend occasional polishing of our polished stainless products to maintain their attractive finish. **Use an approved stainless steel chrome or aluminum mag wheel polish cleaning product** which can be purchased from any automotive parts supplier.