



TRUE FRAME MOUNTED CAMPER TIE DOWNS

IMPORTANT OWNER-OPERATOR INSTALLATION INSTRUCTIONS

C3203/FMTCHRO-6.5

REAR TIEDOWNS W/ FACTORY INSTALLED RECEIVER

Minor movement (or settling) can occur in some incidental harsh driving conditions (on or off road).

A rubber bed mat is not a requirement to maintain the lifetime warranty on a Torklift system, but a strong recommendation, simply as a safety precaution to protect the truck bed, the bottom of the camper and to give the camper additional support.

Warning!!

TORKLIFT DOES NOT RECOMMEND: Installing your truck camper in your truck on top of a drop in plastic bed liner!!! THIS WILL VOID YOUR WARRANTY!

The drop in plastic bed liners can slide on top of the truck bed surface, and the camper can slide on top of the slick surface of the bed liner. The liner can also act as a spring causing a trampoline effect increasing vertical truck camper movement, independent of the vehicle, possibly resulting in truck bed damage and/or camper damage!

C3203 PARTS INVENTORY

2 - TIEDOWN RECEIVERS

2 - BENT TIEDOWN INSERTS

2 - 1/4" PINS

THIS KIT USES FACTORY
FASTENERS FOR INSTALLATION

INSTALLATION INSTRUCTIONS

1. Locate and inventory all parts to become familiar with all brackets.
2. Hold the tiedown receiver into place to locate the proper pre-existing holes in the frame at the end of frame rails near the bumper and bottom of frame (see **photos page 3**). Remove the bolts in the side of the frame and remove the bolts in the bottom of the frame. These bolts will be re-used in the installation of the tiedown.
3. Hold the tiedown receiver into place reinstall the two bolts in the bottom of the frame and the two bolts in the side of the frame (see **page 3**).
4. Find one insert and 1/4" pin and put the bent insert into the receiver using either hole in the insert. Install 1/4" pin.

***NOTE:** The included tie down inserts come with 2 predrilled pin hole locations. When hooking up your camper, either hole may be used providing there is a **MINIMUM** of 2" clearance between the chain/turnbuckle attaching assembly and the truck bed wall. **THERE ARE ALSO 2 PRE-PUNCHED HOLES LOCATED ON THE TRIANGULAR BULLET PLATE ON THE END OF EACH TIE DOWN INSERT, EITHER OF THE TWO HOLES CAN BE USED, BUT THE HOLE THAT PROVIDES THE GREATEST ANGLE IS PREFERRED.**

5. You should have at least 1" clearance between the insert and the lip of the truck bed or aftermarket accessory. Tighten all fasteners. 1/2" bolts to 60 ft. lbs.

INSTALLATION DIAGRAM

DRIVERS SIDE LOOKING FROM UNDERNEATH BUM-



NOTE: Short bed trucks will use the two factory bolts that currently attach the corner bumper brackets to the frame (**SEE PHOTO BELOW**). Loosen the corner bumper support bracket at the bumper (both the upper and lower fastener) as this will allow the corner bracket to hinge out from the frame after removing the two nuts which attach the corner bracket to the frame.

DRIVERS SIDE LOOKING FROM REAR CORNER



*USE
THESE
FACTORY
FASTENERS*

INSTRUCTIONS FOR MAINTENANCE OF POLISHED STAINLESS STEEL PRODUCTS



Torklift utilizes quality grade 304 stainless steel in this product.

304 stainless steel is well known for its anti corrosive properties, however in some environments such as coastal regions or when in contact with some road chemicals, corrosion may occur.

We recommend occasional polishing of our product to maintain its attractive finish. Use an approved stainless steel cleaning/polishing product which can be purchased from any automotive supplier.

Frame Mounted Tie Downs



Leading the camper tie down industry in strength, quality, advanced design and installation. TorkLift TRUE frame mounted tie downs are far superior to all tie down systems available.

The TorkLift system is unique in its design and is patented. Four independent tie down points (with no belly or crossbar) working much like your receiver type trailer hitch as the inserts are removable allowing the system to be virtually undetectable when not in use.

They are designed for each make and model to fit tight to the frame so as not to compromise ground clearance. TorkLift tie downs are not universal 'one size fits all' therefore all the problems with correct fit for each particular application have been eliminated.

Super Hitch

High strength extended hitch system engineered for safely towing all types of trailers behind your truck and camper. With a towing capacity of 12,000 lbs. with an extension, (17,000 lbs. without) the SuperHitch is rated the strongest in the industry.



CONTACT YOUR LOCAL DEALER FOR MORE DETAILS

TORKLIFT'S BOLT FISHING GUIDE

Your guide to understanding the installation of our frame mounted tie downs.

Coiled End of Bolt Fisher

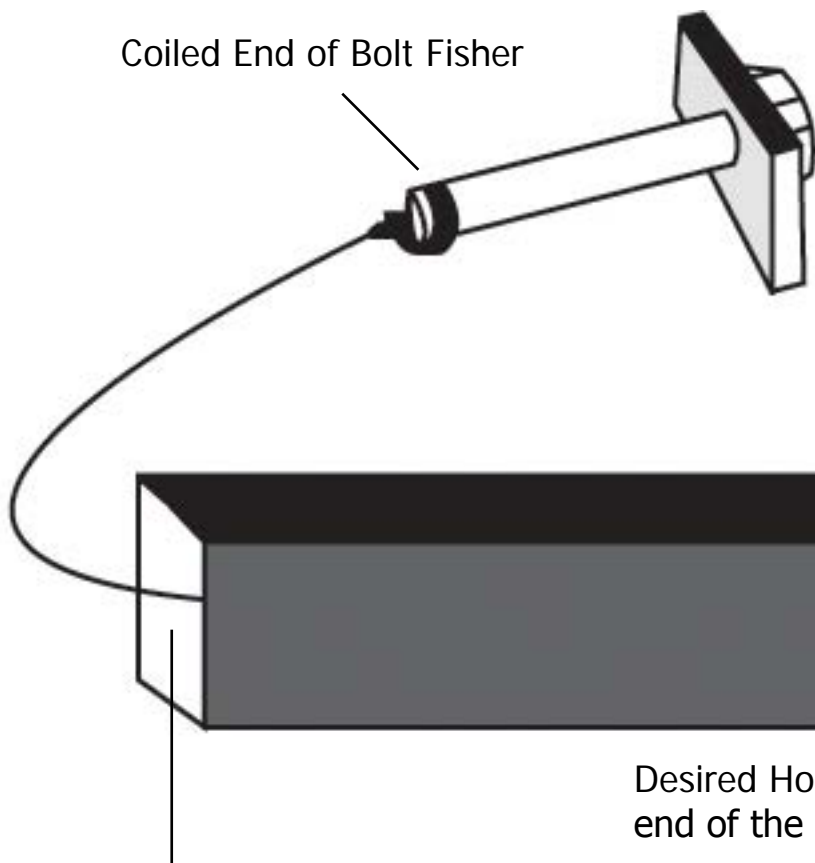

Note: The hardware may vary as to what is being fished along with the bolt. In this instance a 1" X 2" plate washer is being fished along with the hex bolt. Different applications may require fishing through various star washers and flat washers for example.

Desired Hole on Vehicle (Place the coiled end of the bolt fisher through this hole).

This side of the Bolt Fisher should come out of a hole where the required hardware (for example 1" X 2" plate washer) can pass through

Opposite End of Bolt Fisher

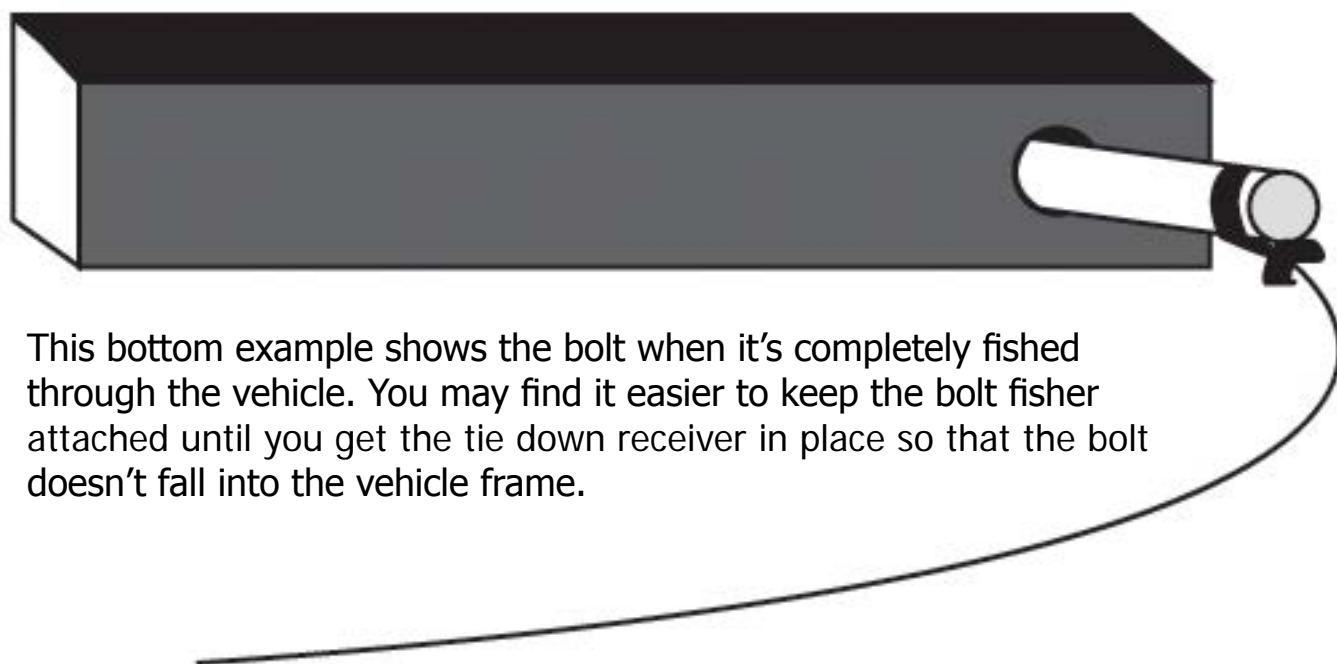

This bottom example shows the bolt when it's completely fished through the vehicle. You may find it easier to keep the bolt fisher attached until you get the tie down receiver in place so that the bolt doesn't fall into the vehicle frame.

WARNING: PULLING TOO HARD ON THE BOLT FISHER CAN RESULT IN LOST FASTENERS, OR BROKEN BOLT FISHER.

TIEDOWN INSERT INSTALLATION INSTRUCTIONS

On one end of each of your tiedown inserts is a triangular plate referred to by Torklift as a bullet plate. Your tiedown inserts should be installed with the shorter side of the bullet plate facing away from each other, i.e.. The shorter side of the front insert should point to the front of the truck and the shorter side of the rear insert should point towards the rear of the truck.

Once installed, attach the TorkLift directional stickers to the face of the bullet plate on the insert as a reminder.

DRIVERS SIDE FRONT

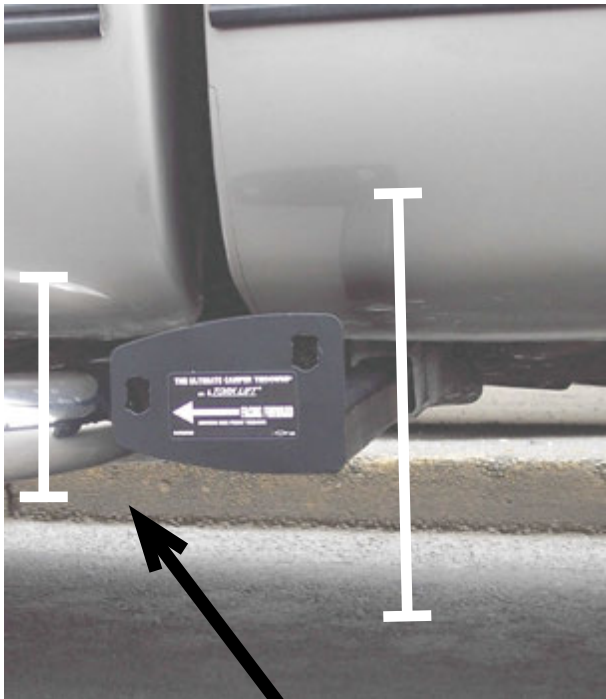

DRIVERS SIDE REAR

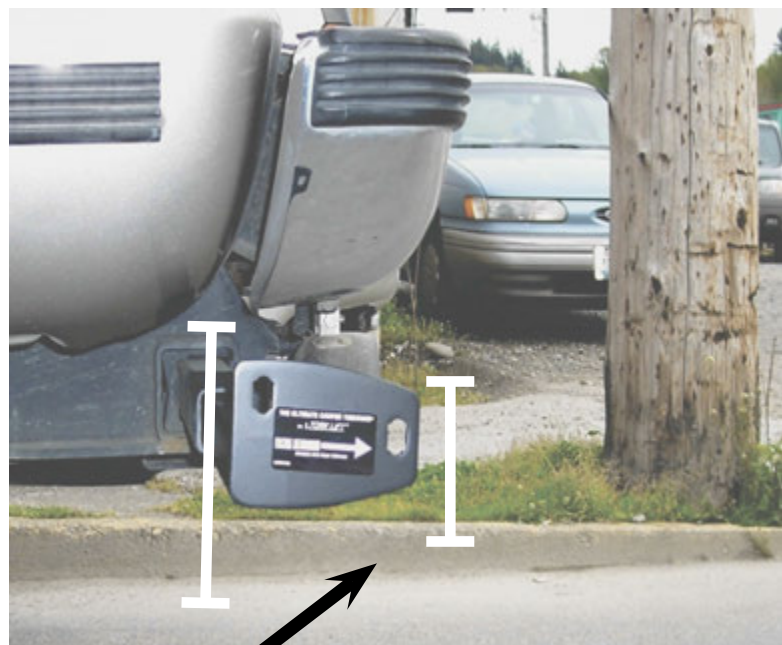

SHORTER SIDE

TURNBUCKLE SPRINGLOAD OPTIONS

CONTACT YOUR LOCAL DEALER FOR MORE DETAILS

Torklift requires all 4 tiedown points to be spring loaded in order to qualify for our manufacturer's

Industry Exclusive Camper Anchor and Truck Frame Warranty

BASIC SPRINGLOAD KIT - \$9000

Includes 2 External Springload Units
& 2 Heavy Duty Forged Turnbuckles.
Lifetime Guarantee



FASTGUNS LEVER ACTION TURNBUCKLES

S9520-GREY SS / S9521-WHITE SS / S9527-POLISHED SS
FOR BED MOUNTED TIEDOWNS

S9522-GREY SS/ S9523-WHITE SS/ S9526-POLISHED SS
S9529-BLACK SS

FRAME OR BUMPER MOUNTED TIEDOWNS

Includes 2 Stainless Steel Turnbuckles with an Internal
"Set" Spring. Available in 2 Lengths and 3 Finishes
(Grey, White or Polished Stainless Steel)
Lifetime Guarantee



FASTGUN DERRINGERS

Zinc S9524

Stainless Powdercoat S9525

Polished Stainless S9528

Transforms Your Pre-Existing Conventional
Turnbuckles into a Lever Action
FastGun Style Turnbuckle.
Kit includes 4 lever action Derringers



SPRINGLOAD XL KIT - \$9050

This set includes 2 Long Chrome Barreled
Turnbuckles with an Internal "Set" Spring.
The Springload XL Kit comes with a Pol-
ished Chrome Finish and is compatible
with the FastGun Derringers.
2 year warranty

RECOMMENDED TRUCK CAMPER

INSTALLATION INSTRUCTIONS

When securing any heavy load (especially a camper) in your truck bed, your front tie down points should pull the load forward as much as possible. Some camper anchor points may differ with different manufacturers, as well as the camper jack mounting locations. Your Torklift tie down inserts have offset triangular brackets to increase the angle of pull. These are designed to be used in the front facing forward, and the rear facing rearward but can be used in either front or rear. These recommendations are to be considered and followed as a basic rule of thumb . Obviously there will be some applications where this may not be possible. At a minimum, if opposite pull of both front and rear tiedowns cannot be achieved for whatever reason, you should have at least a forward pull at the front or rear location.

If your camper does not come with Rubber Bumpers on the front lower portion of the camper, installing Rubber Bumpers (Torklift has Rubber Bumpers available Part A7001) or using a block of wood such as a 2 x 4 in the bed, will prevent the camper from damaging the front bulk head of the truck bed.

Minor movement (or settling) can occur in some incidental harsh driving conditions (on or off road). A rubber bed mat is not a requirement to maintain the lifetime warranty on a Torklift system, but a strong recommendation simply as a safety precaution to protect the truck bed, the bottom of the camper and to give the camper additional support.

TORKLIFT DOES NOT RECOMMEND: Installing your truck camper in your truck on top of a drop in plastic bed liner!!! The drop in plastic bed liners can slide on top of the truck bed surface, and the camper can slide on top of the slick surface of the bed liner. The liner can also act as a spring causing a trampoline effect increasing vertical truck camper movement, independent of the vehicle, possibly resulting in truck bed, and camper damage!

INSTRUCTIONS FOR FINISH MAINTENANCE **OF TORKLIFT PRODUCTS**

POWDER COATED STEEL:

To keep your Torklift products looking good follow these guidelines. All steel powder coated Torklift products are sandblasted for maximum adhesion and use a high quality industrial urethane based powder coat. Due to the extreme, harsh, undercar environment that your Torklift products live in, (consistently sprayed with corrosive road chemicals such as salt, and road debris), Torklift does not warranty the powder coated finish.

To minimize corrosion from these factors on powder coated steel products, Torklift recommends regularly cleaning and inspecting the powder coated surface and touching up any affected areas with an enamel or urethane based aerosol paint product. If there are any areas of surface rust, there are also aerosol spray rust converters available on the market that can be used as a preparation to touch-up paint application. These finish maintenance products are available at any automotive parts supplier.

POLISHED STAINLESS STEEL :

Torklift utilizes quality grade 304 stainless steel in our stainless steel polished products. 304 stainless steel is well known for its anti-corrosive properties. However, in some environments such as coastal regions or when coming in contact with some road chemicals, corrosion may occur.

For a quick clean simply use WD40 and a cloth rag. We also recommend occasional polishing of our polished stainless products to maintain their attractive finish. Use an approved stainless steel chrome or aluminum mag wheel polish cleaning product which can be purchased from any automotive parts supplier.