

TORKLIFT

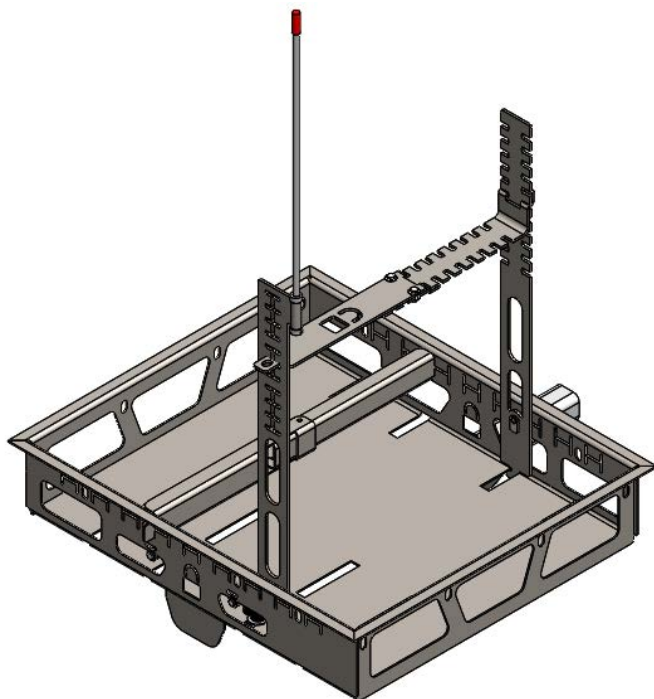







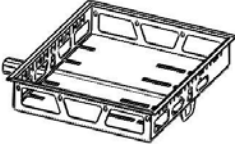

INTERNATIONAL

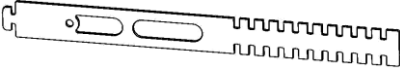





**OVER 35 YEARS OF INNOVATION, QUALITY, SAFETY.
IMPORTANT OWNER-OPERATOR INSTALLATION INSTRUCTIONS**

Part A7752

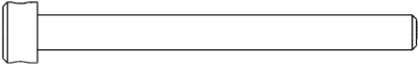
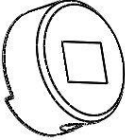

Parts Inventory

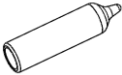
Item Image	Item Description	Quantity
	Lock and Load Base	1
	Movable Vertical Strap	1
	Fixed Vertical Strap	1
	Straight Horizontal Strap	1
	Bent Horizontal Strap	1
	Inner Divider Channel	1
	Outer Divider Channel	1
	5/8" Hitch Pin and Clip	1
	3/8"-16 T-Knob	2
	3/8"-16 x 1" Grade 5 Hex Bolt	1
	3/8" USS Flat Washer	1

Item Image	Item Description	Quantity
	3/8" Fender Washer	1
	1/4" x 2-1/4" Snapper Pin	1
	Heavy Duty Lock	1
	1/4"-20 x 3/4" Grade 5 Hex Bolts	4
	1/4" USS Flat Washers	8
	1/4"-20 Thin SS Nylock Hex Nuts	4
	3/8" Fiberglass Rod	1
	3/8" Red Vinyl Cap	1
	3/8" Set Screw Collars	2
	1/8" Allen Key	1

Step 1:

Remove the **Lock and Load Base** from the packaging. Insert it into the receiver hitch of your vehicle and pin it in place with the supplied **5/8" Pin and Clip**

Place the item you want to secure into the **Lock and Load Base** and slide it to one of the corners of the base closest to the vehicle.

Step 2:

Note the location of the slot in the bottom of the tray that will work the best for mounting the adjustable strap assembly. Typically, this is the slot closest to the middle of the item.

Also, note the location of the divider slots in the front and back of the **Lock and Load Base** that are closest to the edge of the item you wish to secure. See figure 2.1 below.

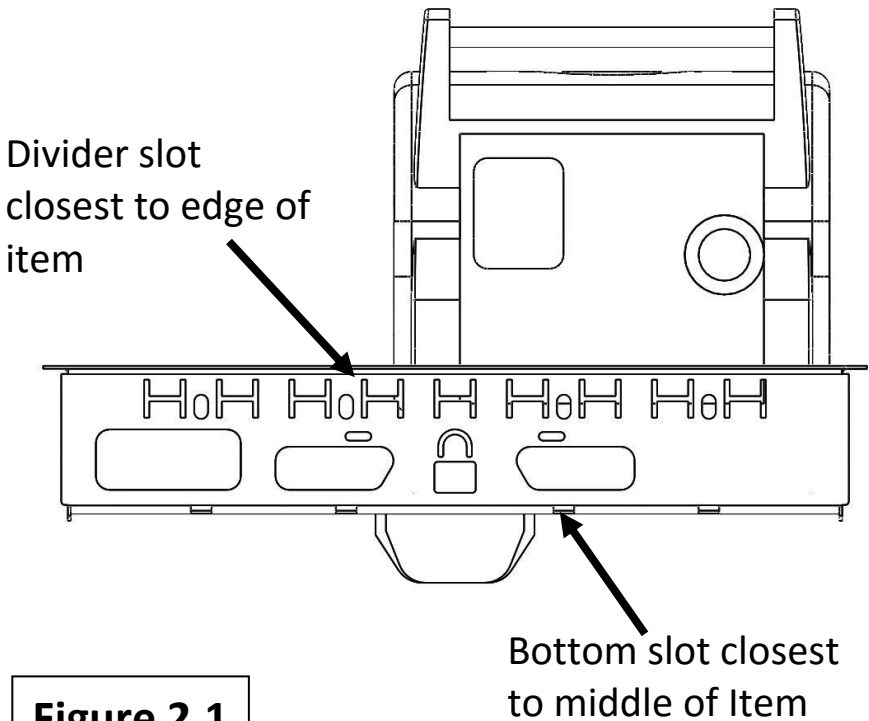

Figure 2.1

Step 3:

Remove the Item from the **Lock and Load Base**, and insert the **Fixed Vertical Strap** into the desired **Bottom Slot** on the side closest to the vehicle as shown in figure 3.1

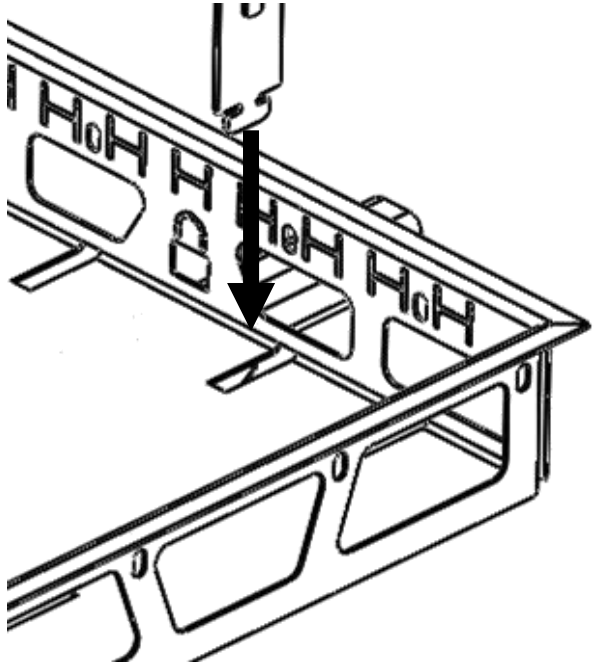

Figure 3.1

Twist the **Vertical Strap** so that the weld nut at the bottom is facing in towards the middle of the **Lock and Load Base**, and then secure it to the side of the **Lock and Load Base** with a **3/8" USS Flat Washer** and one **3/8"-16 T-Knob** as shown in figure 3.2.

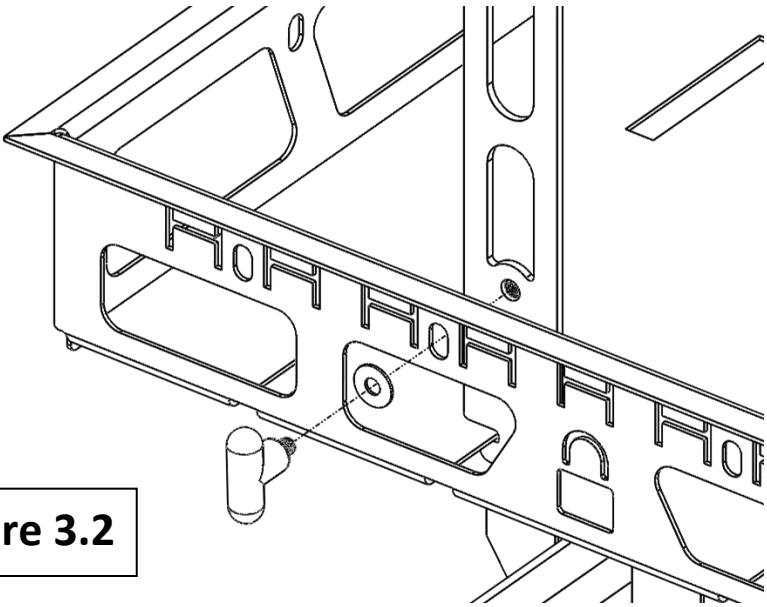

Figure 3.2

Step 4:

Hold the **Movable Vertical Strap** at an angle and install it into the slot opposite of the **Fixed Vertical Strap** as shown in figure 4.1.

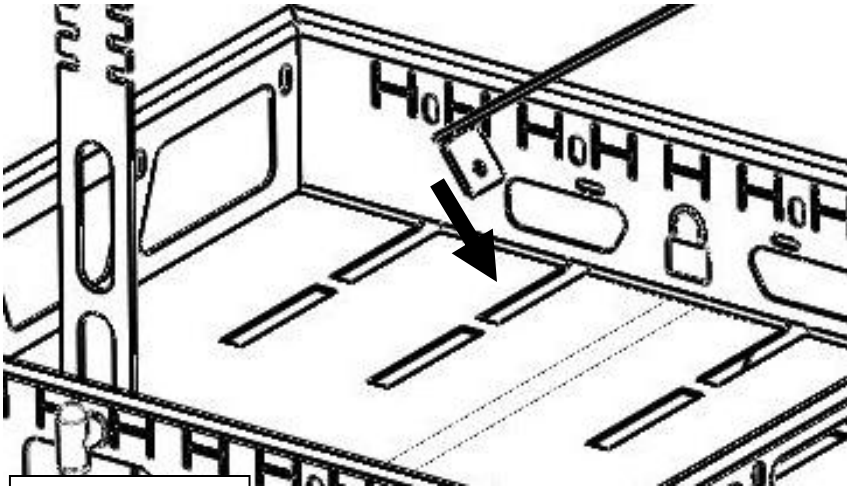

Figure 4.1

Once inserted, rotate the strap so that the bottom tab is facing towards the outside of the **Lock and Load Base**. Loosely secure the **Movable Vertical Strap** with one **3/8" Fender Washer** and a **3/8"-16 T-Knob**. See figure 4.2 below.

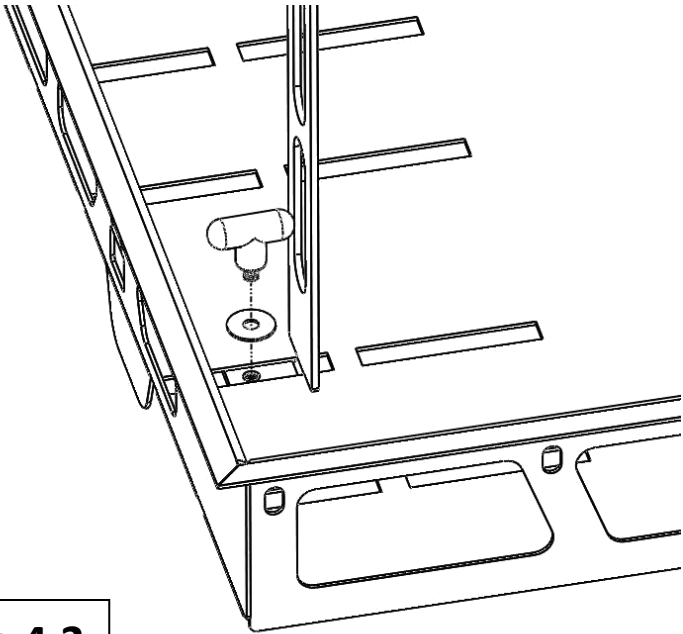

Figure 4.2

Note: If more space is required for the item to fit, the **movable strap** can be reversed in the slot with the bend tab facing inwards. The **3/8"-16 T-Knob** would be replaced with a **3/8"-16 x 1" Grade 5 Bolt**, which would sit under the item.

Step 5:

Hook the **Inner Divider Channel** around the hinge pin in the **Outer Divider Channel** as shown in figure 5.1

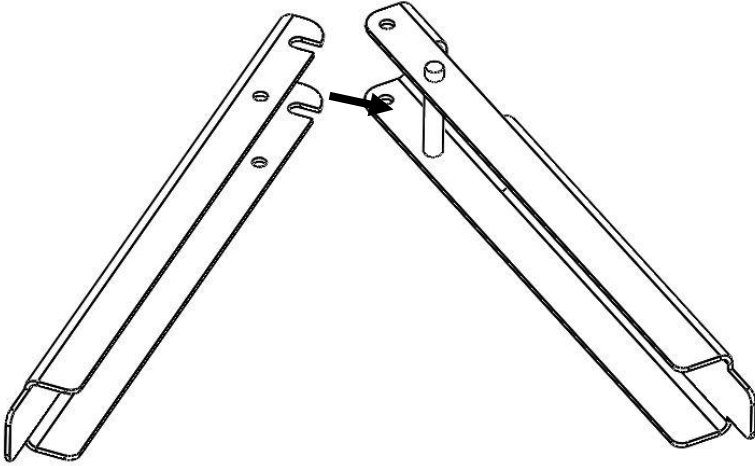

Figure 5.1

With the item removed from the **Lock and Load Base**, place the two tabbed ends of the assembled divider into the appropriate slots in the sides of the **Lock and Load Base** as shown in figure 5.2. The assembled divider should be bent towards the location where the item will sit. This will prevent removal of the divider once the item is in place.

Item to be located on this side

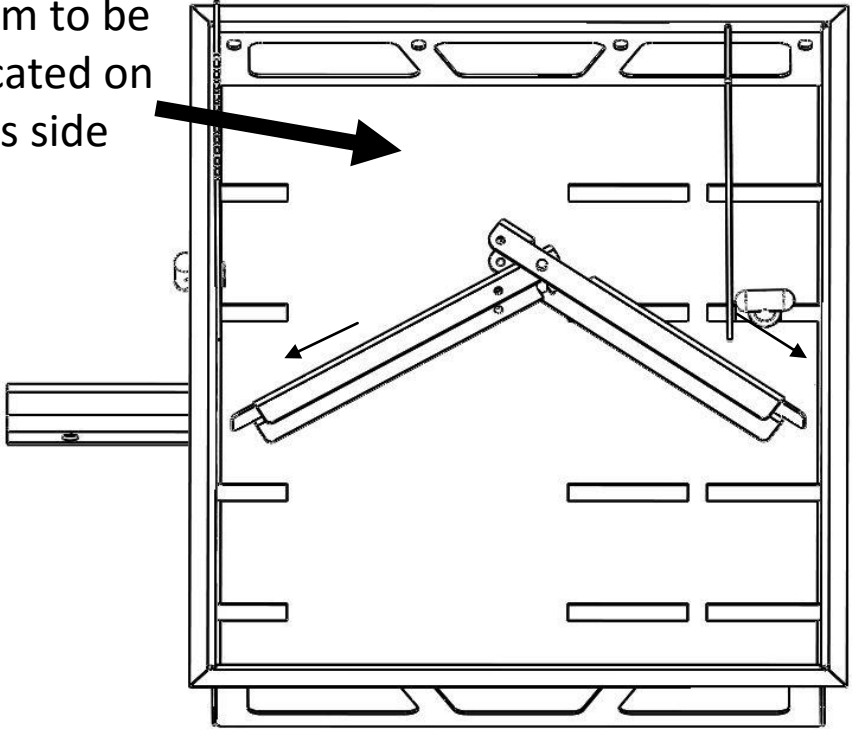

Figure 5.2

Straighten the divider and install a **1/4" x 2-1/4" Snapper Pin** in the hole as indicated in figure 5.3. With the item in place in the **Lock and Load Base**, the assembled divider will not be able to be removed.

Install 2.25"
Snapper Pin in
this hole

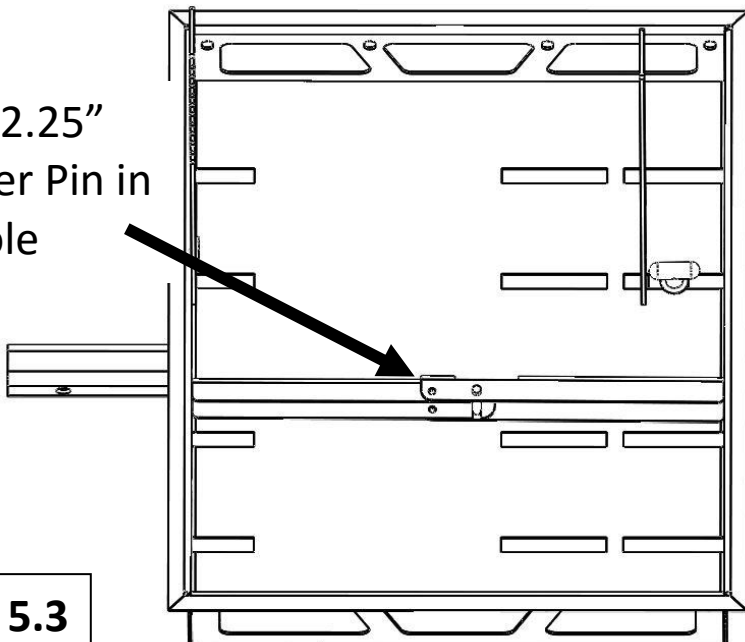

Figure 5.3

Step 6:

Place the item to be secured back into the **Lock and Load Base**. Slide the **movable strap** up against the item and tighten the **3/8"-16 T-Knob**.

Install the **Bent Horizontal Strap** into the teeth on the vertical strap. Choose the set of teeth that will position **Bent Horizontal Strap** as close to the item as possible. See figure 6.1

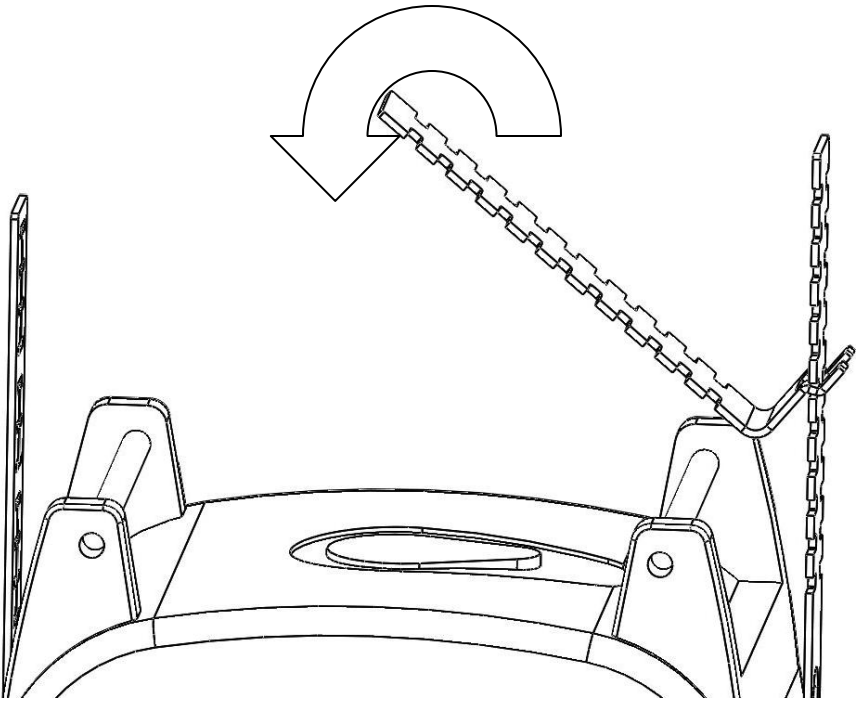

Figure 6.1

Step 7:

Install the **Straight Horizontal Strap** into the **Bent Horizontal Strap** at the location that will most closely match the **Movable Vertical Strap**. See figure 7.1

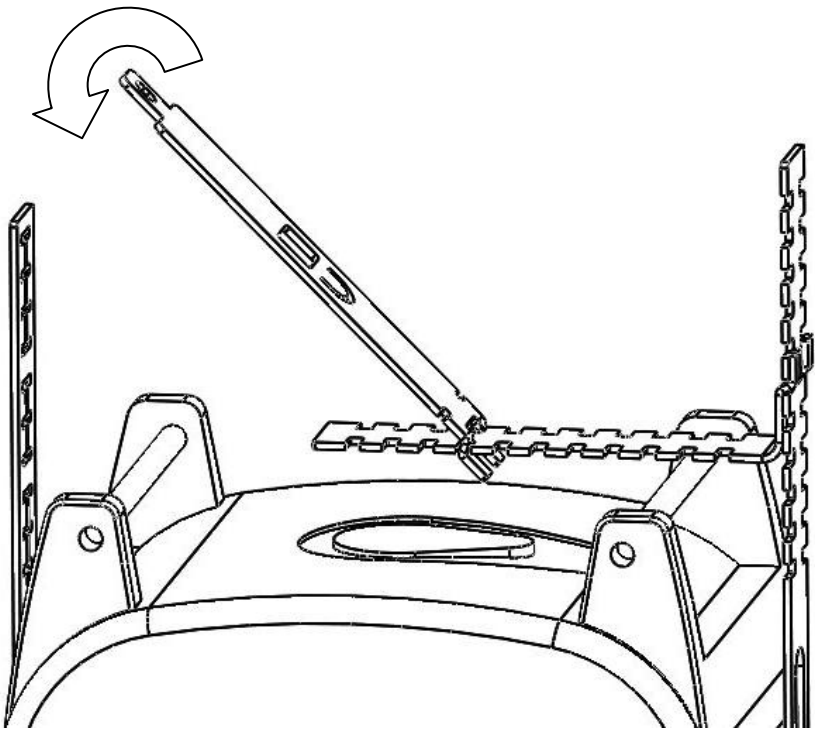

Figure 7.1

Step 8:

Flex the **Movable Vertical Strap** away from the item to allow for the locking tab on the **Straight Horizontal Strap** to be installed through it.

Secure the **Straight Horizontal Strap** through the **Movable Vertical Strap** with the supplied **Heavy Duty Lock**.

Step 9:

Using customer supplied straps, secure the item down so it does not move during transportation. Oval holes for hooking straps can be found throughout the vertical sides of the Lock and Load Base.

The item is now locked and ready for travel.

Lock maintenance

To ensure your **Heavy Duty Lock** is in optimal working condition and corrosion resistant, we recommend lubing the inside of the lock with a silicone spray at least every six months.

Optional Steps

Step 10 (securing horizontal straps):

If the customer wishes to limit movement of the horizontal straps, they can be secured together using two **1/4"-20 x 3/4" Grade 5 Hex Bolts**, four **1/4" USS Flat Washers**, and two **1/4"-20 Thin SS Nylock Hex Nuts** as shown in figure 10.1

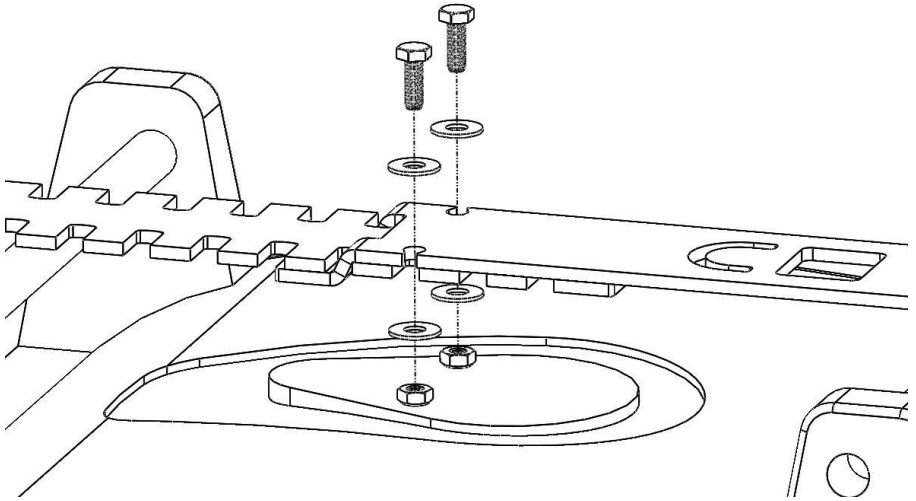

Figure 10.1

Step 11 (license plate relocation):

If the Lock and Load obstructs the vehicle's License Plate, the License Plate can be relocated to the side of the Lock and Load farthest away from the vehicle. Using two **1/4"-20 x 3/4" Grade 5 Hex Bolts**, four **1/4" USS Flat Washers**, and two **1/4"-20 Thin SS Nylock Hex Nuts**, secure the license plate to the **Lock and Load Base** as shown in figure 11.1

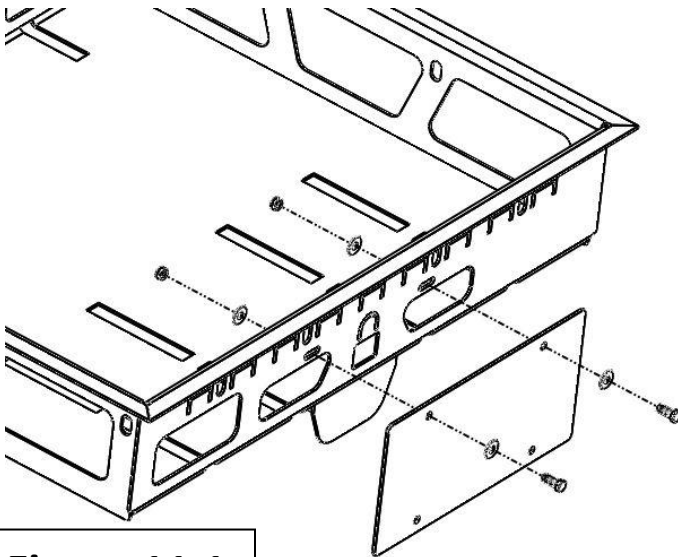

Figure 11.1

Step 12 (visual indicator kit):

To increase safety and visibility of the Lock & Load, a visual indicator kit has been included.

Install the **Red Vinyl Cap** onto one end of the **3/8" Fiberglass Rod**. Slide one **3/8" Set Screw Collar** onto the rod and install the assembly down through the welded pipe on the top of the **Moveable Vertical Strap**.

Install the second **Set Screw Collar** onto the bottom of the **3/8" Fiberglass Rod** that is protruding downwards.

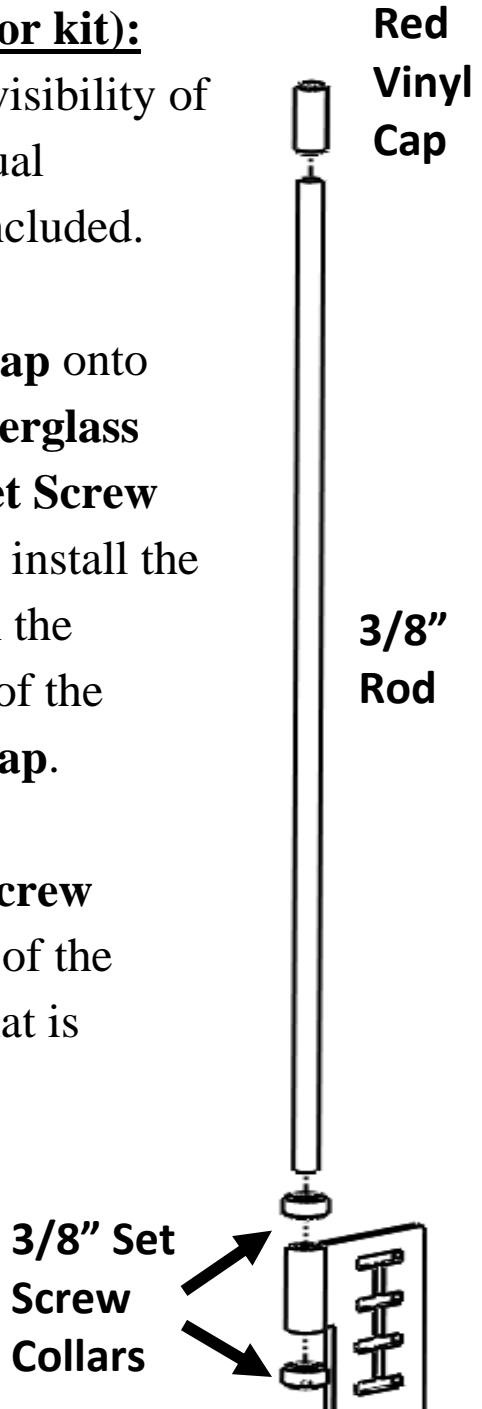

Adjust the height of the **3/8" Fiberglass Rod** until the **Red Vinyl Cap** is clearly visible from inside the vehicle. Secure the **3/8" Rod** in place by tightening the **Set Screw Collars** snugly on each side of the welded pipe. Use the supplied **Allen Wrench** and reference Figure 12.1.

Figure 12.1

