



OVER 35 YEARS OF INNOVATION, QUALITY, SAFETY.
IMPORTANT OWNER-OPERATOR INSTALLATION INSTRUCTIONS

A7740

HIDDEN POWER

2003-2009

2500, 3500 - Quad Cab Long Bed - No Drill Application

2006-2012

2500, 3500 - Mega Cab Short & Long Bed - No Drill Application

2009-2012

2500, 3500 - Crew Cab Long Bed - No Drill Application

All Years - Universal Fit

E450 Based RVs - Drill Application

A7740 INVENTORY LIST

- | | |
|---|--------------------------------------|
| 1- Frame Plate | 1- Triangular Strap |
| 1- Battery Tray | 4- 0.25"-20 x 0.75" Hex Bolt |
| 4- 1/4" Lock Washer | 4- 1/4"-20 Hex Nut |
| 4- 1/4" Washer USS | 4- 1/4" Fender Washer |
| 2- 3/8"-16 x 2" Hex Bolt Grade 8 | 2- 3/8"-16 Flanged Nylock Nut |
| 2- 3/8"-16 Hex Nut | 1- Battery Box Strap |
| 3- 1/2"-13 x 4" Hex Bolt Grade 5 | 2- 7" Black Zip Tie |
| 6- 1/2" Washer SAE | 3- 1/2" Lock Washer |
| 3- 1/2"-13 Hex Nut | 1- 1/4" x 1-3/8" Bail Pin |
| 2- 50A Power Connector | 1- Group 24-31 Battery Box |
| 3- 1/2" x 1.5" Hex Bolt | 1- 1/2" Bolt Fisher |
| 3- 1/2" Star Washer | |

Locate and inventory all parts to become familiar with all brackets. Read and understand all instructions prior to installation. Make sure the vehicle is in park, on a level surface and wheels are chocked before starting the installation.

For Installation on Ram Trucks, Continue to Step 1

For Installation on E450 Based RVs, Continue to Step 3

RAM Installation:

Step 1-

Slide the **Frame Plate** up between the inside of the frame and the fuel lines. On some quad cabs, you will need to slide the **Frame Plate** up so it straddles the fuel line retainer. With the **Triangular Strap** on the outside of the frame, place two **1/2"-13 x 4" Hex Bolt Grade 5** with one **1/2" Washer SAE** each through the **Frame Plate** and **Triangular Strap**. Secure each bolt with an additional **1/2" Washer SAE, 1/2" Lock Washer, and 1/2"-13 Hex Nut**. Leave nuts loose at this time. Some trucks have a wiring harness attached to the top of the frame with plastic zip ties. If the wiring harness cannot be moved enough to allow the bolts to fit under it, then cut the zip ties. **See Photo 1.1**

Secure the bottom of the **Frame Plate** to the **Triangular Strap** with a **1/2"-13 x 4" Hex Bolt Grade 5** and a **1/2" Washer SAE** on either side, followed by a **1/2" Lock Washer** and **1/2"-13 Hex Nut**. **See Figure 1.2**

Photo 1.1



Figure 1.2

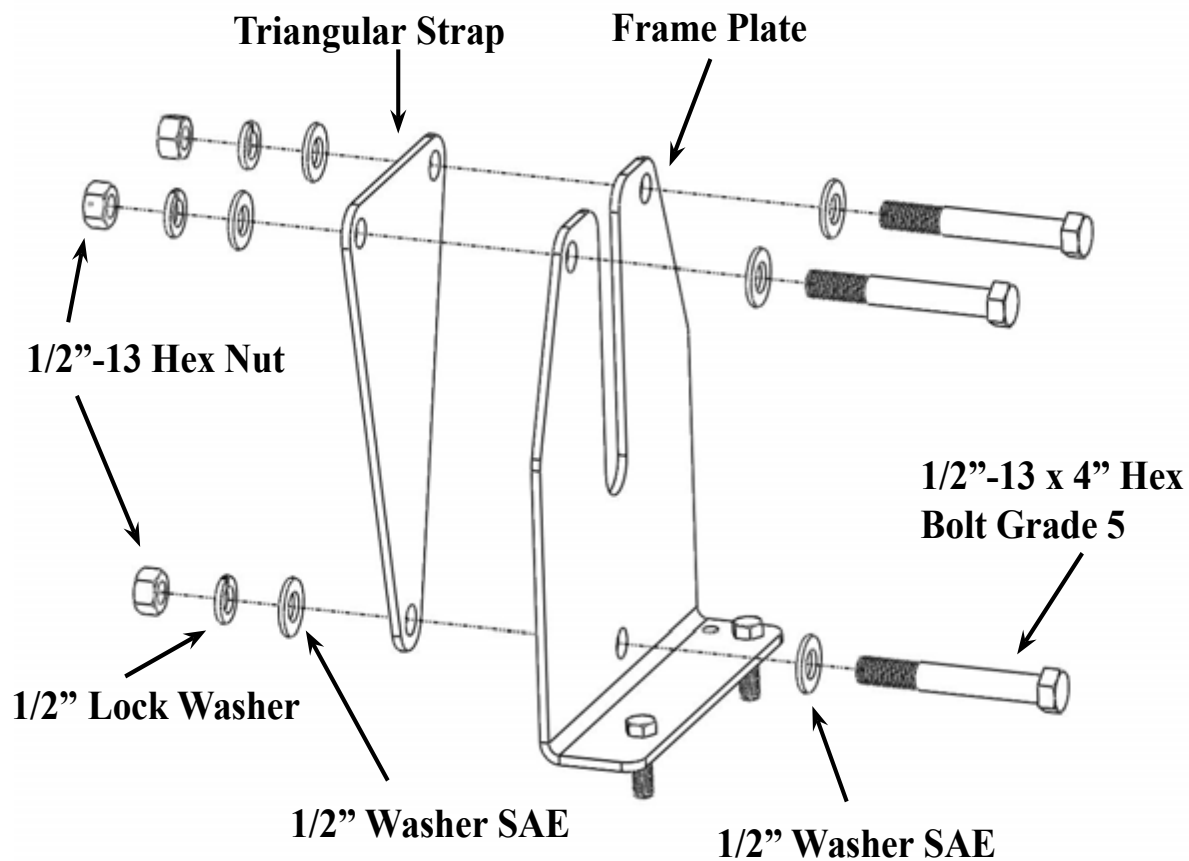

Step 2-

While holding the **Triangular Strap** against the frame, finger tighten all **1/2"-13 Hex Nuts**. Once the nuts are finger tight and the **Triangular Plate** is flat against the frame, torque all **1/2"-13 Hex Nuts** to 15 Ft-Lbs. (20nm)

If you previously cut the wiring harness zip ties, you can reattach the wiring harness to the upper **1/2"-13 x 4" Hex Bolt Grade 5** using the supplied **7" Black Zip Tie**. The zip tie will be able to fit under the **1/2"-13 x 4" Hex Bolt Grade 5** towards the side of the frame where the frame corners are curved.

Ram truck installation- Continue to Step 6.

E450 Based RV Installation

Step 3-

Locate a clear flat section on the outside of the frame where you would like to install the Hidden Power. Hold up the **Group 24-31 Battery Box** so ensure ample room for installation. Once installed, the bottom of the battery box will sit between 1/4" and 1" below the frame. The battery box will also need enough space to slide fore and aft in the vehicle approximately 2" in order to be installed and removed.

Step 4-

Hold the **Frame Plate** up against the frame. With the bottom of the **Frame Plate Flange** between 1/4" and 1" below the bottom of the frame, use a felt tipped pen to transfer the location of three holes to the frame.

Double check the back side of the frame to make sure fuel lines and wiring harnesses will be clear of the hole locations. Multiple holes are available on the hidden power to aid in avoiding critical components. Drill the marked locations with a 1/2" drill bit. If the back of the frame is obstructed, it will be required to drill the holes to 5/8" in order to accommodate the **bolt fisher**.

Step 5-

Depending on clearance, the **bolt fisher** may be required to install the hardware. Insert the coiled end of the **bolt fisher** into one of the holes drilled in the frame. Guide the **bolt fisher** out the nearest opening large enough to fit the hardware. Place one **1/2" Star Washer** onto a **1/2"-13 x 1.5" Hex bolt**, and then attach the hex bolt to the coiled end of the **bolt fisher**.

Pull the **bolt fisher** with bolt and washer back through the frame so the threads of the bolt stick out from the frame.

Place the **Frame Plate** over the **bolt fisher** and bolt. Carefully remove the **bolt fisher** and secure the bolt with one **1/2" Washer SAE**, one **1/2" Lock Washer**, and one **1/2"-13 Hex Nut**.

Repeat the process for the remaining two holes, and torque the bolts to 50 ft-lbs (68 nm). See figure 5.1.

Figure 5.1

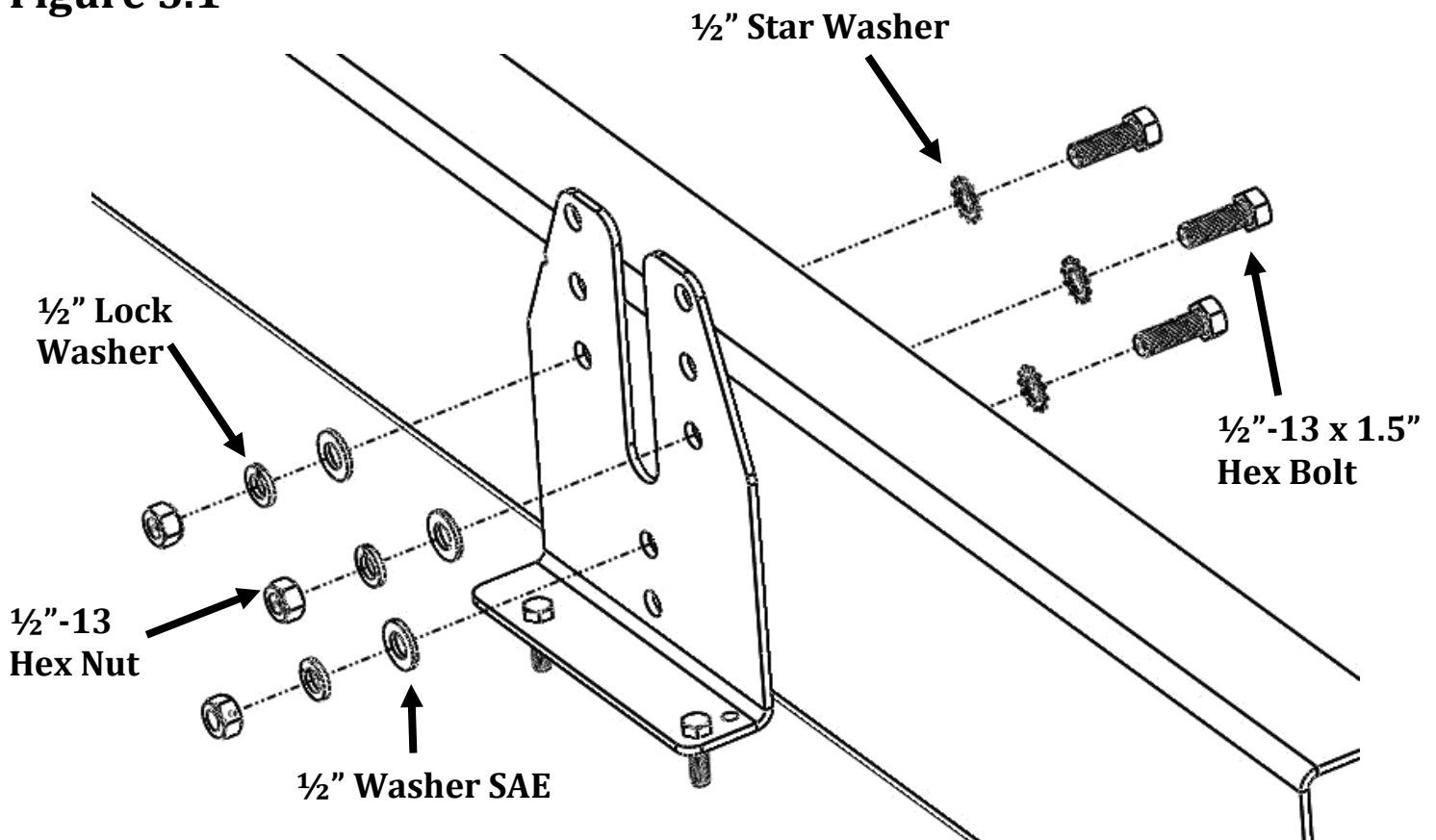

Step 6-

Place a **3/8"-16 Flanged Nylock Nut** on the bottom of each **Frame Plate** stud. Leave approximately **3/8"** of space between the **Frame Plate** and **3/8"-16 Flanged Nylock Nut**.

Step 7-

Lift the **Battery Tray** up to the **Frame Plate**, with the **Frame Plate** studs going through the large portion of the keyholes in the **Battery Tray**. Slide the **Battery Tray** to the rear of the vehicle and lightly tighten the **3/8"-16 Flanged Nylock Nut** with a wrench. With the **Battery Tray** in place, lift the empty **Group 24-31 Battery Box** onto the **Battery Tray**. Place the **Group 24-31 Battery Box** in a position where it will not interfere with any moving parts, fuel lines, or brake lines, then mark the **Battery Tray** holes onto the bottom of the **Group 24-31 Battery Box**. If the **Group 24-31 Battery Box** is not centered on the **Battery Tray**, make sure that the empty side of the **Group 24-31 Battery Box** is the side that overhangs the **Battery Tray** the most. In some cases, it may be necessary to cut one or both handles off of the **battery box** lid for the **battery box** to fit in place.

Step 8-

Remove the **Group 24-31 Battery Box** and **Battery Tray**. Drill four 1/4" holes in the previously marked locations. With the supplied **Battery Box Strap** placed between the **battery box** and **battery tray**, secure the **Group 24-31 Battery Box** to the **Battery Tray** using four **1/4"-20 x 3/4" Hex Bolts**, **1/4" Fender Washer**, **1/4" Washer USS**, **1/4" Lock Washers** and **1/4"-20 Hex Nut**. Torque to 7 Ft-Lbs. (9nm) **See Figure 8.1**. Install the battery (*not included*) into the **Group 24-31 Battery Box**, and connect the leads to the appropriate terminals. For your convenience, two **50A Power Connectors** have been included to aid in the installation and future removal of the battery.

**For all questions relating to connecting your new battery to your current system, please contact your local RV Service Center.*

Figure 8.1

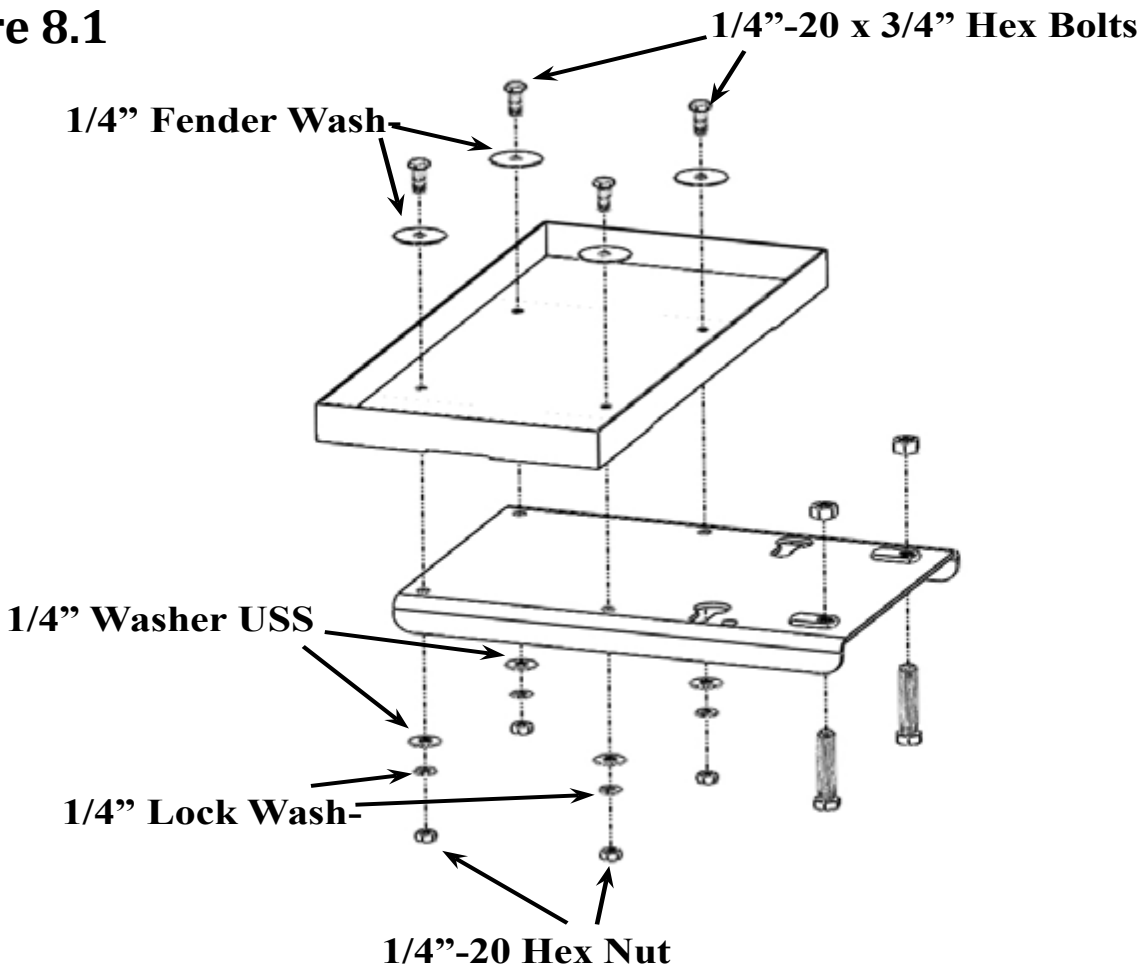

Step 9-

With the battery installed into the **Group 24-31 Battery Box**, lift the **Group 24-31 Battery Box** and **Battery Tray** up to the **Frame Plate** and guide the **Battery Tray** so the **Frame Plate** studs go through the large part of the keyholes in the **Battery Tray**. Slide the **Battery Tray** to the rear of the vehicle so the **Frame Plate** studs are in the small part of the keyholes. While supporting the battery with one hand, install the included **1/4" x 1-3/8" Bail Pin** through the safety hole in the **Frame Plate** and **Battery Tray**. See **Figure 9.2**.

Torque the **3/8"-16 Flanged Nylock Nut** on the **Frame Plate** studs to 25 Ft-Lbs.(33nm)

Figure 9.2

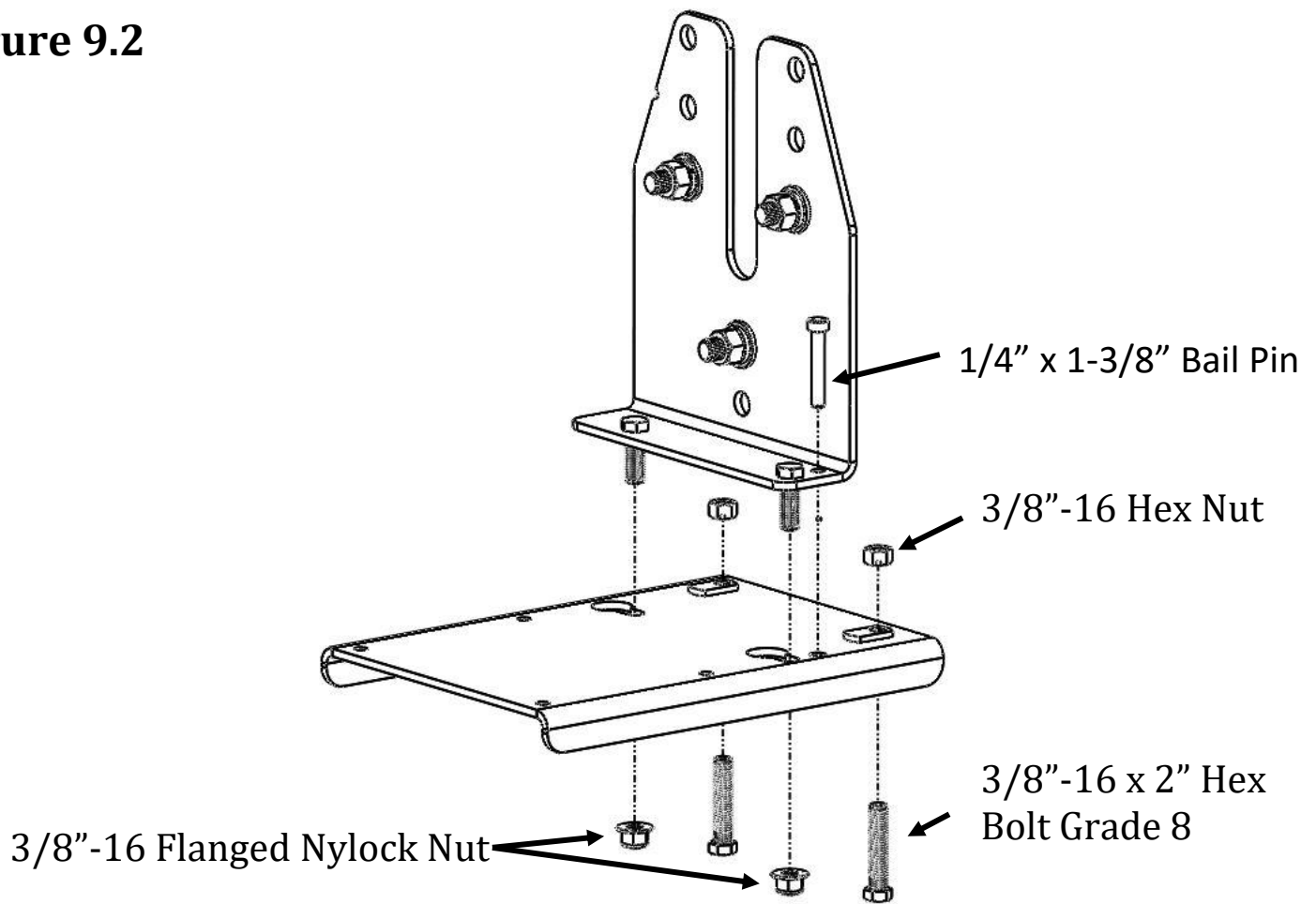

Step 10-

Install the **3/8"-16 x 2" Hex Bolt Grade 8** through the weld nuts in the **Battery Tray** from the bottom side. Install a **3/8"-16 Hex Nut** onto the **3/8"-16 x 2" Hex Bolt Grade 8** from the topside of the **Battery Tray**. Thread the **3/8"-16 x 2" Hex Bolt Grade 8** up by hand until they contact the frame of the truck. Thread the **3/8"-16 Hex Nuts** down on the bolts until they contact the weld nuts on the **Battery Tray**. Snug the nuts tight with a wrench to lock the **3/8"-16 x 2" Hex Bolt Grade 8** in place.

Battery Charging Wire Diagrams

To test if you have a factory battery separator, use a voltmeter or a 12V test light to test for key on/ key off positive power at the RV Plug. See RV Plug Diagram on next page.

***NOTE:** Wire color is going to vary from manufacturer to manufacturer which is why you should always wire by function and use a Volt Meter or a 12V test light when wiring. There is no official industry standard for wire color. If you are trying to wire by matching colors, there is a very good chance that it will be wired incorrectly. Be sure to test each wire to ensure you are wiring for the correct function.*

<u>Pin #</u>	<u>Function</u>
(1)	Ground
(2)	Trailer Brakes
(3)	Tail / Running Lights
(4)	Aux 12V+ (Charging)
(5)	Left Turn / Stop
(6)	Right Turn / Stop
(7)	Backup Lights

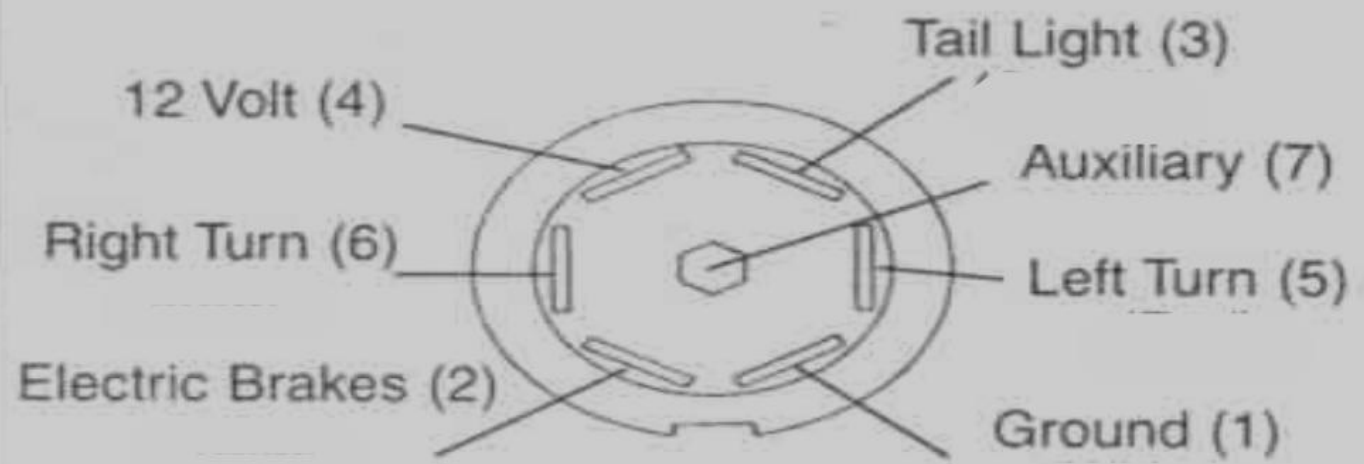

#1 For Trucks with Factory Installed Ignition Activated Tow Package

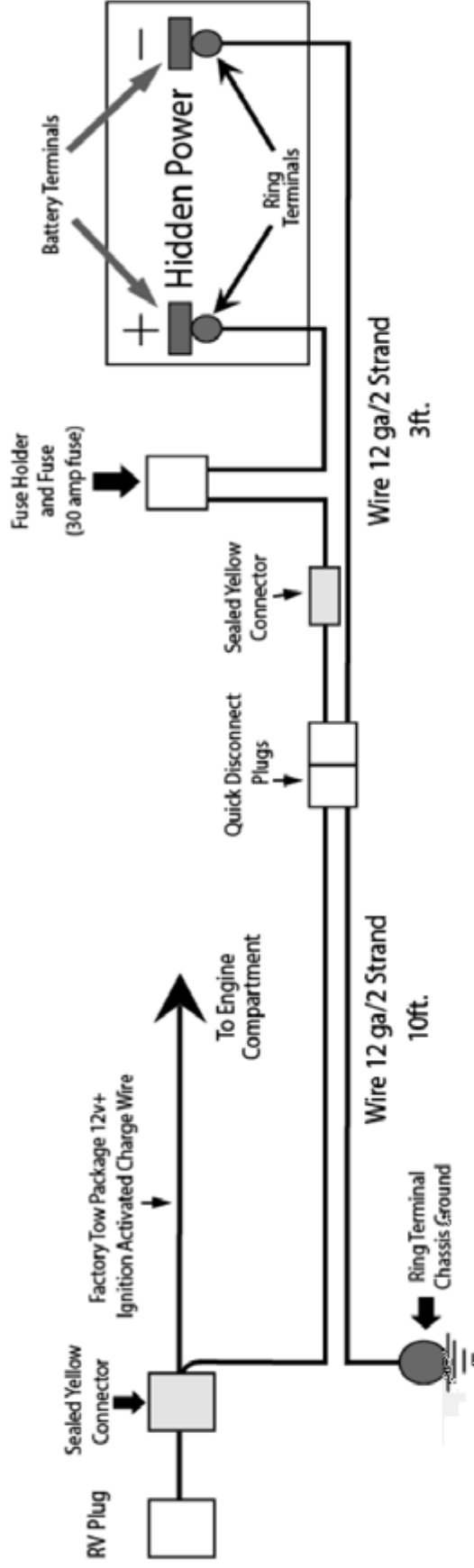

For Trucks without Factory Installed #2 Ignition Activated Tow Package

