

TCE *Professional Series*

3 Ton Low Profile Service Jack

6,000 lbs. LIFTING CAPACITY
Lifting Range: 3-7/8" – 21-1/4"

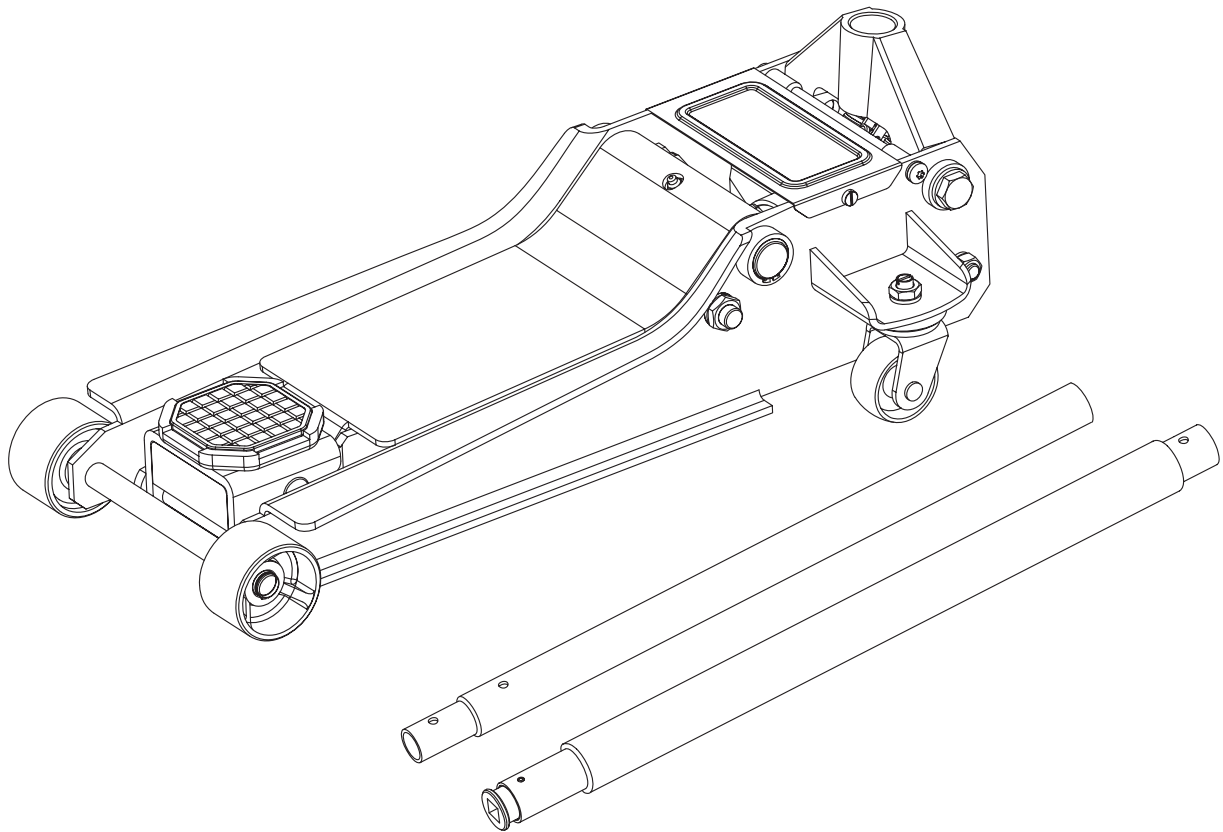

This is the safety alert symbol. It is used to alert you to potential personal injury hazards. Obey all safety messages that follow this symbol to avoid possible injury or death.

PACKAGE CONTENTS

Part	Description	Quantity
A	Jack	1
B	Pump Handle	1

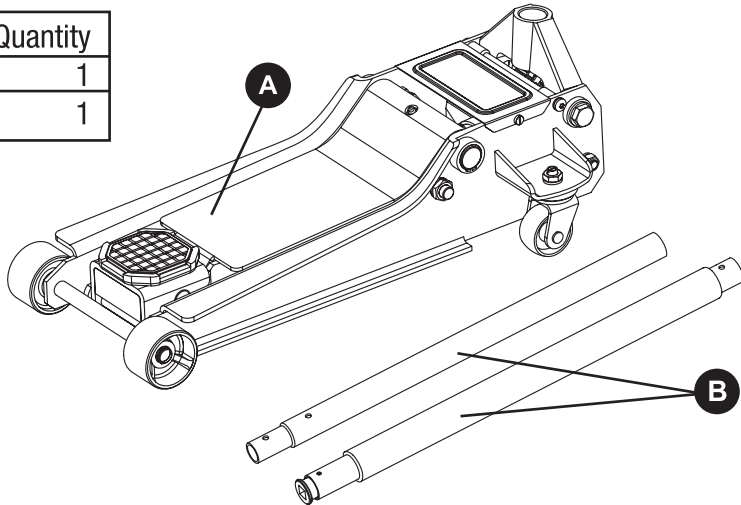

SAFETY INFORMATION

Save these instructions. For your safety, read, understand, and follow the information provided with and on this jack before using. The owner and/or operator of this equipment shall have an understanding of this jack and safe operating procedures before attempting to use. The owner and/or operator shall be aware that the use and repair of this product may require special skills and knowledge. Instructions and safety information shall be conveyed in the operator's native language before use of this jack is authorized. If any doubt exists as to the safe and proper use of this jack, remove from service immediately.

Inspect before each use. Do not use if broken, bent, cracked, or damaged parts (including labels) are noted. Any jack that appears damaged in any way, operates abnormally or is missing parts, shall be removed from service immediately. If you suspect that the jack was subjected to a shock load (a load suddenly dropped unexpectedly upon it), immediately discontinue use until the jack has been checked by a factory authorized service center (contact distributor or manufacturer for list of Authorized Service Centers). It is recommended that an annual inspection be done by qualified personnel. Labels and owner's manuals are available from manufacturer.

PRODUCT DESCRIPTION

Hydraulic Floor Jacks are designed to lift, but not support, one end of a vehicle. Hydraulic Floor Jacks must be used in conjunction with a pair of appropriately rated jack stands.

 **NEVER** use an automotive jack as a stand-alone device. After lifting, immediately support the lifted load with a pair of appropriately rated vehicle support stands

WARNING!

1. READ, STUDY AND UNDERSTAND ALL WARNINGS AND OPERATING INSTRUCTIONS PRIOR TO USE.
2. DO NOT OVERLOAD THIS JACK BEYOND THE RATED CAPACITY.
3. THIS JACK IS DESIGNED FOR USE ONLY ON HARD LEVEL SURFACES CAPABLE OF SUSTAINING THE LOAD.
4. THIS IS A LIFTING DEVICE ONLY. THE LOAD MUST BE SUPPORTED IMMEDIATELY BY JACK STANDS.
5. DO NOT GET UNDER OR ALLOW ANYONE UNDER THE VEHICLE UNTIL IT HAS BEEN SUPPORTED BY JACK STANDS.
6. LIFT ONLY ON AREAS OF THE VEHICLE AS SPECIFIED BY THE VEHICLE MANUFACTURER.
7. CENTER LOAD ON SADDLE PRIOR TO LIFTING.
8. SOME VEHICLES REQUIRE AN ADAPTER TO PROPERLY ENGAGE THE FRAME FOR LIFTING. USE VEHICLE MANUFACTURERS INSTRUCTIONS ON PROPER LIFTING.
9. NO ALTERATIONS TO THE JACK SHALL BE MADE.
10. ONLY ATTACHMENTS, RESTRAINTS, OR ADAPTERS SUPPLIED BY THE MANUFACTURER SHALL BE USED.
11. FAILURE TO HEED THESE WARNINGS MAY RESULT IN PERSONAL INJURY AND/OR PROPERTY DAMAGE.

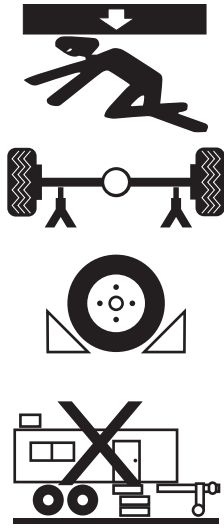
	<p style="text-align: center;">! WARNING!</p> <p>To avoid crushing and related injuries:</p> <ul style="list-style-type: none"> • Never work on, under, or around a load supported only by a hydraulic jack. • Read, understand and follow all printed materials provided with and on this jack. • Immediately support the lifted load with a pair of appropriately rated jack stands. • Use ONLY on vehicles whose lift points are compatible with the saddle of this jack. Incompatibility may result in structural damage to the vehicle and/or jack. • Chock each un-lifted tire in both directions. • Be alert and sober when servicing a vehicle! Never operate this equipment when under the influence of drugs or alcohol. • DO NOT use this device to lift, level, lower, support, adjust or otherwise move a house, mobile home, travel trailer, camper, or building structure of any type, size or configuration.
---	--

! Be sure all tools and personnel are clear before lowering load. Only attachments and/or adapters supplied by the manufacturer shall be used. Lift only on areas of the vehicle as specified by the vehicle manufacturer.

PREPARATION

BEFORE USE (refer to Fig 1)

1. Verify that the product and the application are compatible. If in doubt, contact Customer Support.
2. Before using this product, read the owner's manual completely and familiarize yourself thoroughly with the product and its components, and recognize the hazards associated with its use.
3. To familiarize yourself with basic operation, use the stamped end of the provided handle to engage and turn the release valve:
 - a. Clockwise until firm resistance is felt to further thread engagement. This is the 'CLOSED' release valve position used to raise the load.
 - b. Counterclockwise, but no more than 1/2 turn from the closed position. This is the 'OPEN' release valve position used to lower the load.
4. With saddle fully lowered, locate and remove the cover plate, then remove the oil filler plug. Insert the handle into the handle sleeve; then pump 6 to 8 full strokes. This will help release any pressurized air which may be trapped within the reservoir. Check oil level. Proper oil level will vary from just covering the ram cylinder to 3/16 in. above it as seen from the oil filler plug hole. Reinstall the oil filler plug.
5. Check to ensure that jack rolls freely (if so equipped) and that the pump operates smoothly before putting into service. Replace worn or damaged parts and assemblies with factory authorized replacement parts only. Contact the manufacturer or distributor of this product for a list of factory authorized service centers. Lubricate as instructed in Maintenance Section.

Bleeding / Venting Trapped Air

With the release valve in the OPEN position and with saddle fully lowered, locate and remove the oil filler plug. Insert the handle into the handle sleeve; then pump 6 to 8 full strokes. This will help release any pressurized air which may be trapped within the reservoir. Oil level should be even with the bottom of the oil filler plug hole. Reinstall the oil filler plug.

OPERATING INSTRUCTIONS (Refer to Fig.1)

 This is the safety alert symbol. It is used to alert you to potential personal injury hazards. Obey all safety messages that follow this symbol to avoid possible injury or death.

Lifting

1. Place vehicle in park with emergency brake on and wheels securely chocked to prevent inadvertent vehicle movement.
2. Locate and close release valve by turning handle clockwise until firm resistance is felt to further thread engagement. Center jack saddle under lift point.
3. Verify lift point, insert handle into handle sleeve and pump to contact lift point. To lift, pump handle until load reaches desired height.
4. Transfer the load immediately to a pair of appropriately rated jack stands.

 Use only the handle assembly provided by the jack manufacturer. The handle assembly provided with this jack will safely engage the release valve and operate the handle sleeve. If the handle is worn, operates abnormally, or will not positively engage the release valve, STOP. Discontinue use of the jack until a factory replacement handle assembly can be acquired.

Lowering

1. Raise load high enough to clear the jack stands; then, carefully remove jack stands.
2. Slowly turn the handle counterclockwise, but no more than a ½ turn.
If the load fails to lower:
 - a. Use another jack to raise the vehicle high enough to reinstall jack stands
 - b. Remove the affected jack and then the stands.
 - c. Using the other jack, lower the load by turning the operating handle counterclockwise, but no more than a ½ turn.
3. After removing jack from under the load, push saddle down to reduce ram exposure to rust and contamination.

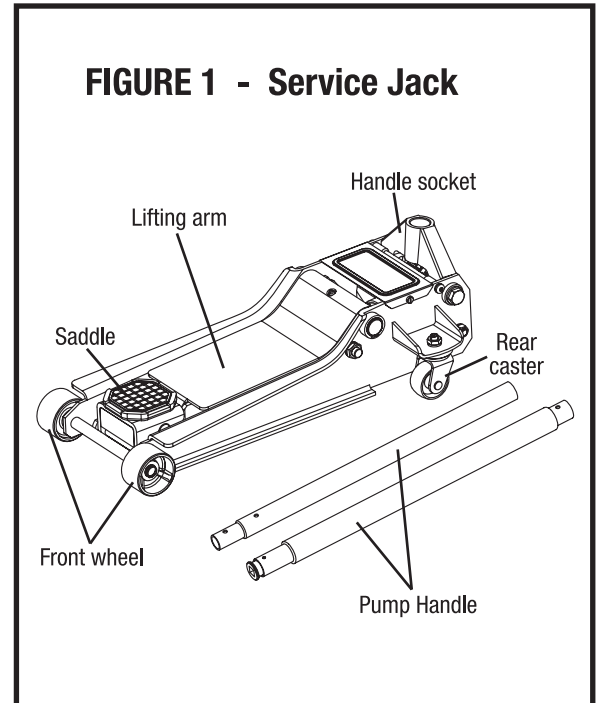

CARE AND MAINTENANCE

Important: Use only a quality grade hydraulic jack oil. Avoid mixing different types of fluid and NEVER use brake fluid, turbine oil, transmission fluid, motor oil or glycerin. Improper fluid can cause failure of the jack and the potential for sudden and immediate loss of load.

Adding oil

1. With saddle fully lowered, set jack in its upright, level position. Locate and remove oil filler plug.
2. Fill with oil even with the bottom of oil filler plug hole. Reinstall the oil filler plug.

Changing oil

For best performance and longest life, replace the complete fluid supply at least once per year.

1. With saddle fully lowered, remove the oil filler plug.
2. Lay the jack on its side and drain the fluid into a suitable container.

Note: Dispose of hydraulic fluid in accordance with local regulations.

3. Fill with oil even with the bottom of oil filler plug hole. Reinstall the oil filler plug.

Lubrication

A periodic coating of light lubricating oil to pivot points will help to ensure that pump piston linkages move freely.

Note: Never apply oil to the saddle. If saddle extension threads require lubrication; clean thread surfaces with a clean, dry cloth, then apply a drop of bearing grease to the threads. Distribute as evenly as possible along the threaded post.

Cleaning

Periodically check the pump piston and ram for signs of rust or corrosion. Clean as needed and wipe with an oily cloth.

Note: Never use sandpaper or abrasive material on these surfaces.

Storage

Store the jack with the pump piston, ram plunger, and saddle fully lowered. Ensure the release valve is open, but never more than ½ turn. This will help prevent rust and corrosion to those critical surfaces.

TROUBLESHOOTING

Symptom	Possible Causes	Corrective Actions
Jack will not lift load	<ul style="list-style-type: none"> Release valve not tightly closed Load is too heavy 	<ul style="list-style-type: none"> Ensure release valve is closed. Use the provided handle to engage the release valve. Turn the release valve clockwise until firm resistance is felt. Consider higher capacity jack.
Jack bleeds off* after lift * "bleeds off" means the load slowly and unintentionally lowers after lifting	<ul style="list-style-type: none"> Hydraulic unit malfunction 	<ul style="list-style-type: none"> Contact Customer Support
While lowering, fluid leaks from reservoir area Jack saddle will not descend to lowest advertised height	<ul style="list-style-type: none"> Reservoir overfilled Ram plunger/cylinder deformed, seized up in ram cylinder and/or top nut, likely the result of off-center loading 	<ul style="list-style-type: none"> Drain fluid to proper level. Contact Customer Support.
Ram plunger will not remain lowered after released from contact with load (creeps back up)	<ul style="list-style-type: none"> Air trapped in system 	<ul style="list-style-type: none"> IF there is no longer contact between the lifted load and the jack saddle, simply remove the jack and follow the Owners Manual Maintenance instructions for bleeding air from system. However, IF there is any loaded contact between the saddle and the vehicle, <u>STOP</u>. Use another jack to raise the load high enough to re-install jack stands. Remove the affected jack, then the stands. Using the other jack, lower the load by turning the release valve counter-clockwise, but never more than 1/2 full turn, then follow the Owners Manual Maintenance instructions for bleeding air from system.
Poor lift performance	<ul style="list-style-type: none"> Fluid level low Air trapped in system Hydraulic unit malfunction 	<ul style="list-style-type: none"> Ensure proper fluid level. Carefully follow the Owners Manual instructions for bleeding/venting the jack. Contact Customer Support.
Will not lift to full extension	<ul style="list-style-type: none"> Fluid level low 	<ul style="list-style-type: none"> Ensure proper fluid level

REPLACEMENT PARTS LIST

Not all components of the jack are replacement items but are illustrated as a convenient reference of location and position in the assembly sequence. When ordering parts, give model number, serial number and description below.

Part No.	Description	Quantity
1	Front wheel assembly	2
2	Saddle	1
3	Socket Handle Screw	1
4	Power unit assembly	1
5	Rear wheel	2
6	Pump Handle	1

