



# 1/2 Ton Double Ram Transmission Jack

***Professional Series***

**1,000 lbs. LIFTING CAPACITY**  
**Lifting Range: 34" – 69-5/16"**  
**Saddle Forward Tilt 38°**  
**Saddle Backward Tilt 15°**

MODEL# TCE50055

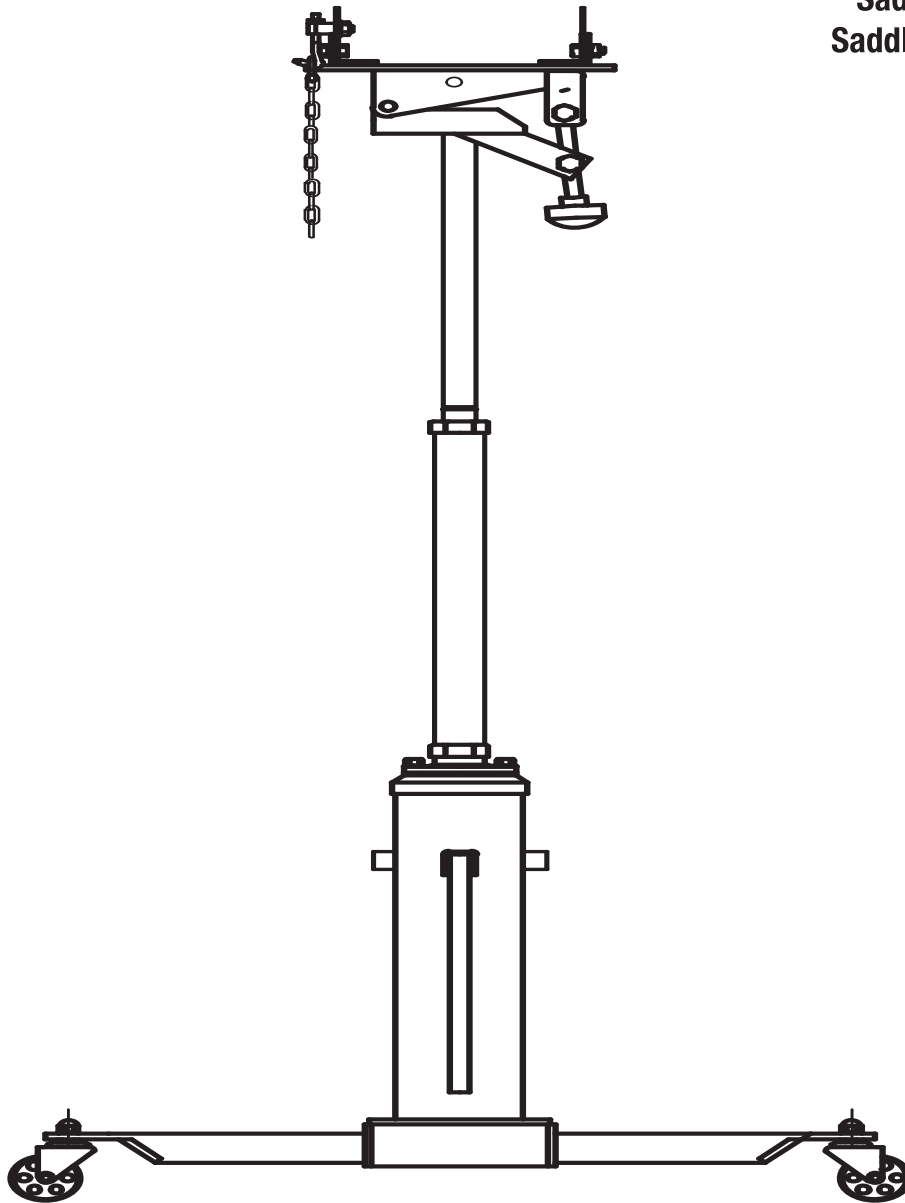

This is the safety alert symbol. It is used to alert you to potential personal injury hazards. Obey all safety messages that follow this symbol to avoid possible injury or death.

---

## PACKAGE CONTENTS

Part	Description	Quantity
A	Saddle Assembly	1
B	Jack Assembly	1
C	Base Frame	2
D	Swivel Caster	4

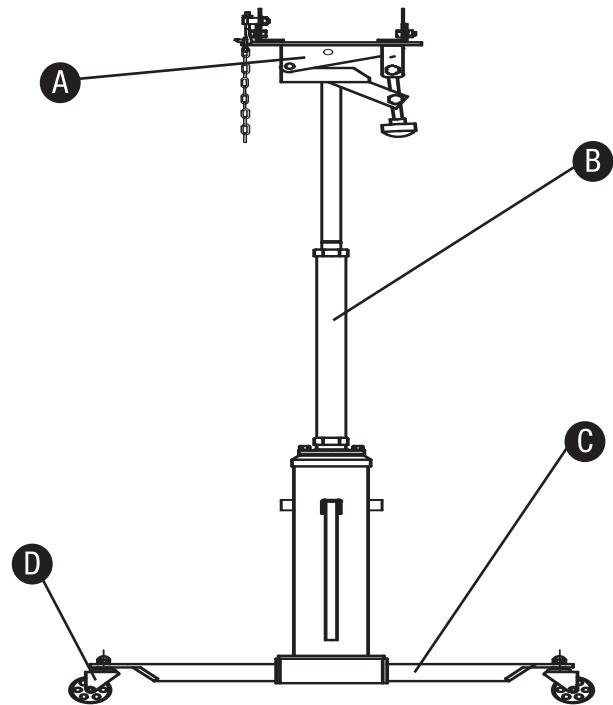

## ⚠ SAFETY INFORMATION

Save these instructions. For your safety, read, understand, and follow the information provided with and on this product before using. The owner and/or operator of this equipment shall have an understanding of safe use/operating procedures before attempting to use. The owner and/or operator shall be aware that the use of this product may require special skills and knowledge. Instructions and safety information shall be conveyed in the operator's native language before use of this device is authorized. If any doubt exists as to the safe and proper use of this product as outlined in this factory authorized manual, remove from service immediately.

Inspect before each use. Do not use if broken, bent, cracked, or damaged parts (including labels) are noted. If the product appears damaged in any way, operates abnormally or is missing parts, it should be removed from service immediately and the manufacturer notified. If you suspect that the product was subjected to a shock load (a load suddenly dropped unexpectedly upon it), immediately discontinue use until product has been checked by a factory authorized service center (contact distributor or manufacturer for list of Authorized Service Centers). It is recommended that an annual inspection be done by qualified personnel. Labels and owner's manuals are available from manufacturer.

### ⚠ WARNING!

1. READ, STUDY AND UNDERSTAND ALL WARNINGS AND OPERATING INSTRUCTIONS PRIOR TO USE.
2. DO NOT EXCEED RATED CAPACITY.
3. USE ONLY ON HARD LEVEL SURFACE.
4. ADEQUATELY SUPPORT THE VEHICLE BEFORE STARTING REPAIRS.
5. USE OF THIS PRODUCT IS LIMITED TO THE REMOVAL, INSTALLATION, AND TRANSPORTATION IN THE LOWERED POSITION, OF TRANSMISSIONS, TRANSFER CASES, AND TRANSAXLES.
6. NO ALTERATIONS SHALL BE MADE TO THIS PRODUCT.
7. ONLY ATTACHMENTS AND/OR ADAPTERS SUPPLIED BY THE MANUFACTURER SHALL BE USED.
8. FAILURE TO HEED THESE WARNINGS MAY RESULT IN PERSONAL INJURY AND/OR PROPERTY DAMAGE.

# PRODUCT DESCRIPTION

Transmission Jack is designed to be used as an aid in the removal and installation of automotive and light truck transmissions, transfer cases and transaxles. It is intended for use under an overhead lift or in a garage pit.

**!** Do not use this device for any purpose other than that for which it is expressly intended.

# ASSEMBLY INSTRUCTIONS

Part	Description	Qty
1	Jack Assembly	1
2	Base Frame	2
3	Bolt M16x70	4
4	Lock Washer 16	4
5	Washer 16	4
6	Swivel Caster 3"	4
7	Washer 12	4
8	Lock Washer 12	4
9	Nut M12	4
10	Bracket	1
11	Fix Bar Assembly	2
12	Bolt M10x20	2
13	Washer 10	2
14	Nut M10	2
15	Chain	2

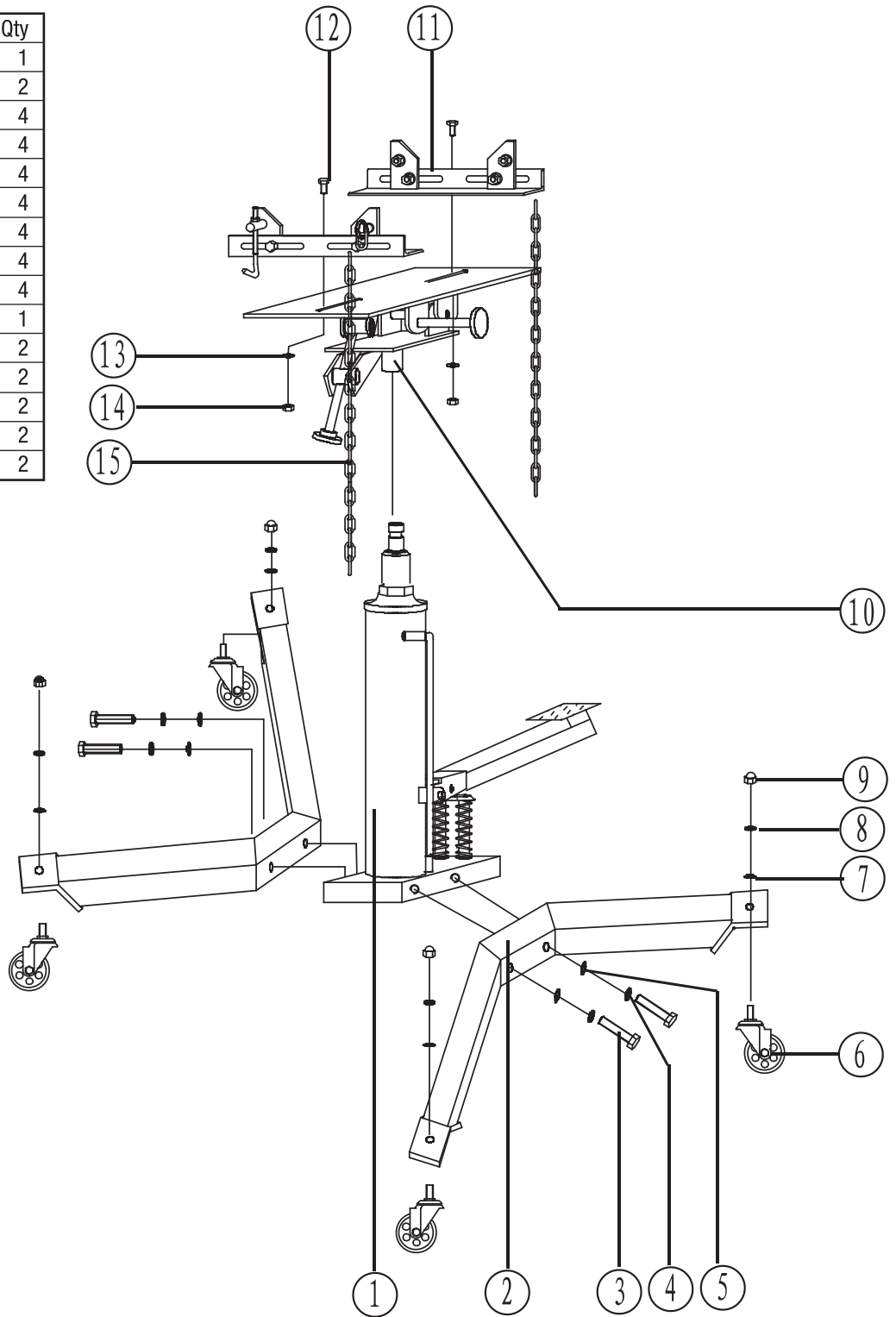

# ASSEMBLY INSTRUCTIONS

---

1. Assemble the swivel casters on the jack legs using lock washers and nuts provided. See assembly diagram.
2. Assemble the legs (with the casters) to the jack's base, and finger tighten the bolts and lock washers provided.
3. Position the jack (with legs) on a hard level surface. Tighten the bolts while all four casters are contacting the floor and the jack appears vertical to the floor.
4. Insert the draw bar into its socket on the cylinder, and secure it with the bolts provided.
5. Loosen the bolt from outside the saddle adapter. Mount the saddle adapter onto the top of the piston rod. Tighten the bolt and secure the entire saddle assembly.
6. Use the tilt adjusting knob to adjust the saddle angle to a relatively horizontal position.
7. Attach the two corner support brackets onto the universal saddle, and fasten with the bolts and nuts.
8. Assemble the fixing bracket on the corner support bracket and secure with the hook and screw caps. Assemble chains and chain hardware to the corner support bracket. The chains and chain hardware are provided to secure the transmission, transfer box, or differential to the saddle assembly by the different shape of their housing. When using, both ends of the chain should be anchored to the bracket.



**WARNING!** DO NOT RAISE, LOWER, OR TRANSPORT A TRANSMISSION UNLESS IT IS SECURED BY THE RESTRAINT SYSTEM. IT IS YOUR RESPONSIBILITY TO ADJUST THE RESTRAINT SYSTEM TO A SUITABLE POSITION. TEQ IS NOT SUBJECT TO ANY RESPONSIBILITY FOR INCORRECT SETUPS OF THE RESTRAINT SYSTEM THAT MAY CAUSE PERSONAL INJURY AND / OR PROPERTY DAMAGE.

# OPERATING INSTRUCTIONS

---

## Raise saddle:

1. Follow the vehicle's recommended service procedure for removal of the component.
2. Position the jack under the vehicle.
3. Raise the jack by operating the foot pump until the saddle touches the component.
4. Adjust the support brackets to fit the component.
5. Use the tilt crank to align the saddle with the component.
6. Finish raising the jack to the component. Secure the chain assembly around the component.

## Lower saddle:

1. Slowly, gently apply downward pressure to the release valve pedal until the component is completely lowered.
2. Immediately transfer the component to an appropriate repair fixture.

# CARE AND MAINTENANCE

---

**Important:** Use only a quality grade hydraulic jack oil. Avoid mixing different types of fluid and NEVER use brake fluid, turbine oil, transmission fluid, motor oil or glycerin. Improper fluid can cause failure of the jack and the potential for sudden and immediate loss of load.

## Adding oil

1. With saddle fully lowered, set jack in its upright, level position. Locate and remove oil filler plug.
2. Fill with oil even with the bottom of oil filler plug hole. Reinstall the oil filler plug.

## Changing oil

For best performance and longest life, replace the complete fluid supply at least once per year.

1. With saddle fully lowered, remove the oil filler plug.
2. Lay the jack on its side and drain the fluid into a suitable container.

**Note:** *Dispose of hydraulic fluid in accordance with local regulations.*

3. Fill with oil even with the bottom of oil filler plug hole. Reinstall the oil filler plug.

## Lubrication

A periodic coating of light lubricating oil to pivot points will help to ensure that pump piston linkages move freely.

Note: Never apply oil to the saddle. If saddle extension threads require lubrication; clean thread surfaces with a clean, dry cloth, then apply a drop of bearing grease to the threads. Distribute as evenly as possible along the threaded post.

## Cleaning

Periodically check the pump piston and ram for signs of rust or corrosion. Clean as needed and wipe with an oily cloth.

Note: Never use sandpaper or abrasive material on these surfaces.

## Storage

Store the jack with the pump piston, ram plunger, and saddle fully lowered.

# TROUBLESHOOTING

Symptom	Possible Causes	Corrective Actions
Jack will not lift load	<ul style="list-style-type: none"> <li>Release valve not tightly closed</li> <li>Load is too heavy</li> </ul>	<ul style="list-style-type: none"> <li>Ensure release valve is closed. Use the provided handle to engage the release valve. Turn the release valve clockwise until firm resistance is felt.</li> <li>Consider higher capacity jack.</li> </ul>
Jack bleeds off* after lift  * "bleeds off" means the load slowly and unintentionally lowers after lifting	<ul style="list-style-type: none"> <li>Hydraulic unit malfunction</li> </ul>	<ul style="list-style-type: none"> <li>Contact Customer Support</li> </ul>
While lowering, fluid leaks from reservoir area  Jack saddle will not descend to lowest advertised height	<ul style="list-style-type: none"> <li>Reservoir overfilled</li> <li>Ram plunger/cylinder deformed, seized up in ram cylinder and/or top nut, likely the result of off-center loading</li> </ul>	<ul style="list-style-type: none"> <li>Drain fluid to proper level.</li> <li>Contact Customer Support.</li> </ul>
Ram plunger will not remain lowered after released from contact with load (creeps back up)	<ul style="list-style-type: none"> <li>Air trapped in system</li> </ul>	<ul style="list-style-type: none"> <li>IF there is no longer contact between the lifted load and the jack saddle, simply remove the jack and follow the Owners Manual Maintenance instructions for bleeding air from system. However, IF there is any loaded contact between the saddle and the vehicle, <b>STOP</b>. Use another jack to raise the load high enough to re-install jack stands. Remove the affected jack, then the stands. Using the other jack, lower the load by turning the release valve counter-clockwise, but never more than 1/2 full turn, then follow the Owners Manual Maintenance instructions for bleeding air from system.</li> </ul>
Poor lift performance	<ul style="list-style-type: none"> <li>Fluid level low</li> <li>Air trapped in system</li> <li>Hydraulic unit malfunction</li> </ul>	<ul style="list-style-type: none"> <li>Ensure proper fluid level.</li> <li>Carefully follow the Owners Manual instructions for bleeding/venting the jack.</li> <li>Contact Customer Support.</li> </ul>
Will not lift to full extension	<ul style="list-style-type: none"> <li>Fluid level low</li> </ul>	<ul style="list-style-type: none"> <li>Ensure proper fluid level</li> </ul>

# REPLACEMENT PARTS LIST

Not all components of the jack are replacement items but are illustrated as a convenient reference of location and position in the assembly sequence. When ordering parts, give model number, serial number and description below.

Part	Description	Qty
1	Jack Assembly	1
2	Base Frame	2
3	Bolt M16x70	4
4	Lock Washer 16	4
5	Washer 16	4
6	Swivel Caster 3"	4
7	Washer 12	4
8	Lock Washer 12	4
9	Nut M12	4
10	Bracket	1
11	Fix Bar Assembly	2
12	Bolt M10x20	2
13	Washer 10	2
14	Nut M10	2
15	Chain	2

