



**THIS OPERATING MANUAL CONTAINS IMPORTANT SAFETY INFORMATION. READ CAREFULLY AND UNDERSTAND ALL INFORMATION BEFORE OPERATING TOOL. SAVE THIS MANUAL FOR FUTURE USE.**

## OPERATING INSTRUCTIONS AND PARTS BREAKDOWN

### BOTTLE JACKS

<b>MODEL T90203</b>	2 Ton	<b>MODEL T91003</b>	10Ton
<b>MODEL T90213</b>	2 Ton	<b>MODEL T91203</b>	12Ton
<b>MODEL T90403</b>	4Ton	<b>MODEL T91207A</b>	Stubby 12 Ton
<b>MODEL T90413</b>	4 Ton	<b>MODEL T91603</b>	16 Ton
<b>MODEL T90603</b>	6 Ton	<b>MODEL T92003</b>	20 Ton
<b>MODEL T90613</b>	6 Ton	<b>MODEL T92007A</b>	Stubby 20 Ton
<b>MODEL T90803</b>	8 Ton	<b>MODEL T93007</b>	Stubby 30 Ton
		<b>MODEL T95007</b>	Stubby 50 Ton

## OPERATING INSTRUCTIONS

### Before using the jack:

- Using the handle, open the release valve by rotating it counterclockwise one full turn.
- Place the handle in the handle socket and pump about 6 full strokes to purge the air from the pump and valving.
- Close the release valve. Pump the handle until the jack has reached full extension. Continue to pump several times to purge air from under the ram.
- Open the release valve and push ram into its lowest position. Close the release valve and operate normally.

**Note:** If the jack responds immediately to pump action, it is free of air and ready for operation. If not, repeat procedure.

### To use the jack:

- To raise a load**, close release valve by rotating the handle firmly in a clockwise direction (do not overtighten). Carefully position the jack under the load and pump the jack handle to raise the load to the desired height.
- If raising a vehicle, always support it with vehicle stands before working on the vehicle or getting under it for any reason.
- To lower the load**, slowly rotate the jack handle counterclockwise just enough to open the release valve. Opening the release valve more permits the load to descend faster.

**IMPORTANT:** As with any hydraulic unit, this unit may occasionally become "air bound" due to being tipped over during shipment. To purge the air from the oil lines, open the release and pump rapidly a few strokes. Close release and pump to full height, then open the release to allow the ram to descend rapidly. If the pump still seems "spongy", repeat the procedure.

**! WARNING**

- Read, study and understand all warnings and operating instructions prior to use.
- Do not overload this jack beyond the rated capacity.
- This jack is designed for use only on hard level surfaces capable of sustaining the load.
- This is a lifting device only, immediately after lifting, support the vehicle with jack stands.
- Do not get under or allow anyone under the vehicle until it has been supported by jack stands.
- Lift only on areas of the vehicle as specified by the vehicle manufacturer.
- Center load on saddle prior to lifting.
- Some vehicles require an adapter to properly engage the frame for lifting. Use vehicle manufacturers instructions on proper lifting.
- No alterations to the jack shall be made
- Only attachments, restraints, or adapters supplied by the manufacturer shall be used.
- Failure to heed these warnings may result in personal injury and/or property damage.

**! WARNING**

**USE JACK FOR LIFTING ONLY.**  
**LOAD MUST BE SUPPORTED IMMEDIATELY**  
**BY OTHER APPROPRIATE MEANS.**

## PARTS BREAKDOWN —

<b>MODEL T90203</b>	2 Ton
<b>MODEL T90213</b>	2 Ton
<b>MODEL T90403</b>	4 Ton
<b>MODEL T90413</b>	4 Ton
<b>MODEL T90603</b>	6 Ton
<b>MODEL T90613</b>	6 Ton
<b>MODEL T90803</b>	8 Ton
<b>MODEL T91003</b>	10Ton
<b>MODEL T91203</b>	12Ton
<b>MODEL T91207A</b>	Stubby 12 Ton
<b>MODEL T91603</b>	16 Ton
<b>MODEL T92003</b>	20 Ton
<b>MODEL T92007A</b>	Stubby 20 Ton

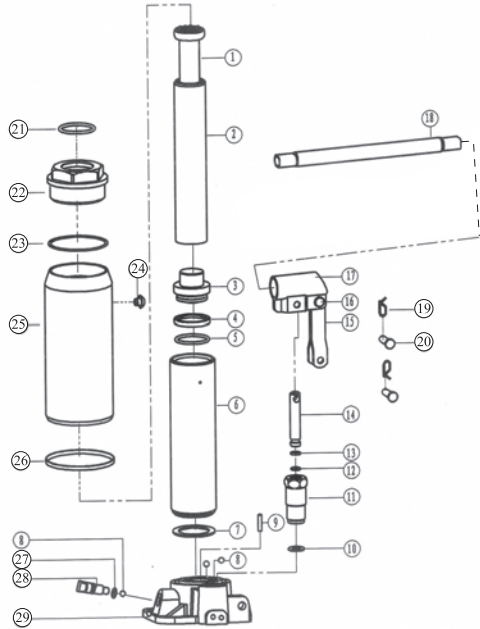

REF. NO.	PART NO.	DESCRIPTION	QTY.	REF. NO.	PART NO.	DESCRIPTION	QTY.
1		Extension Screw	1	17		Handle Sleeve	1
2		Ram	1	18		Handle	1
3		Ram Piston	1	19		Cotter Pin	2
4	*	Back Up Ring	1	20		Pin	2
5	*	O Ring	1	21	*	O Ring	1
6	*	Cylinder	1	22	*	Top Nut	1
7	*	Oil Seal Of Cylinder	1	23	*	Seal	1
8	*	Steel Ball	3	24	*	Filler Plug	1
9	*	Filter	1	25	*	Reservoir	1
10		Washer	1	26	*	Seal	1
11	*	Oil Fill Screw	1	27	*	Seal	1
12	*	Filler Screw Packing	1	28		Release Valve	1
13	*	Back Up Ring	1	29		Base	1
14		Pump Plunger	1				
15		Connecting Rod	1				
16		Short Pin	1				

## SPECIFICATIONS

Model No.	T90203 T90213	T90403 T90413	T90603 T90613	T90803	T91003	T91203	T91207A
<b>Capacity</b>	2 Tons	4 Tons	6 Tons	8 Tons	10 Tons	12 Tons	12 Tons
<b>Closed Height</b>	7-1/8"	7-5/8"	8-1/2"	9-1/8"	9-1/16"	9-1/8"	7-1/2"
<b>Raised Height</b>	13-5/8"	14-5/8"	16-1/4"	18"	18-1/8"	18-1/4"	13-13/16"

## INSPECTION

Visual inspection should be made before each use of the bottle jack, checking for damaged, loose or missing parts. Each jack must be immediately inspected by a manufacturer's repair facility if subjected to an abnormal load or shock. Any jack which appears to be damaged in any way, found to be badly worn, or operates abnormally **MUST BE REMOVED FROM SERVICE** until necessary repairs are made by a manufacturer's authorized repair facility. It is recommended that an annual inspection of the jack be made by a manufacturer's authorized repair facility and that any defective parts, decals or warning labels be replaced with manufacturer's specified parts.

A list of authorized repair facilities is available from the manufacturer.

## OWNER/USER RESPONSIBILITY

The owner and/or user must have a thorough understanding of the manufacturer's operating instructions and warnings before using this bottle jack. Personnel involved in the use and operation of equipment must be careful, competent, trained, and qualified in the safe operation of the equipment and its proper use when servicing motor vehicles and their components. Warning information must be emphasized and understood. If the operator is not fluent in English, the manufacturer's instructions and warnings must be read to and discussed with the operator in the operator's native language by the purchaser/owner, making sure that the operator comprehends its contents.

Owner and/or user must study and maintain for future reference the manufacturer's instructions. Owner and/or user is responsible for keeping all warning labels and instruction manuals legible and intact.

## MAINTENANCE

1. To add oil, place jack in upright position with pump plunger down. Remove filler plug and add hydraulic jack oil to level of filler hole. Be sure oil is clean and be careful to keep dirt out of jack. **DO NOT USE BRAKE, SHOCK ABSORBER, OR TRANSMISSION FLUID.**
2. Periodically lubricate the points indicated with SAE 30 oil. Keep jack clean.
3. Occasionally check extension screw and pump plunger for corrosion. Keep these parts lubricated to prevent corrosion.
4. When not in use, store jack in upright position in a dry location with pump plunger and extension screw in lowest position and release valve closed.

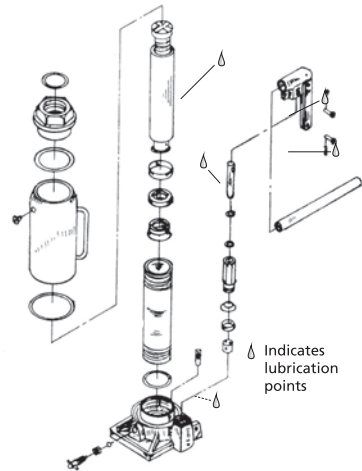

## SPECIFICATIONS

Model No.	T91603	T92003	T92007A
Capacity	16 Tons	20 Tons	20 Tons
Closed Height	9-1/8"	9-1/2"	6-5/8"
Raised Height	18-1/16"	17-3/4"	10-15/16"

## PARTS BREAKDOWN —

**MODEL T93007** Stubby 30 Ton  
**MODEL T95007** Stubby 50 Ton

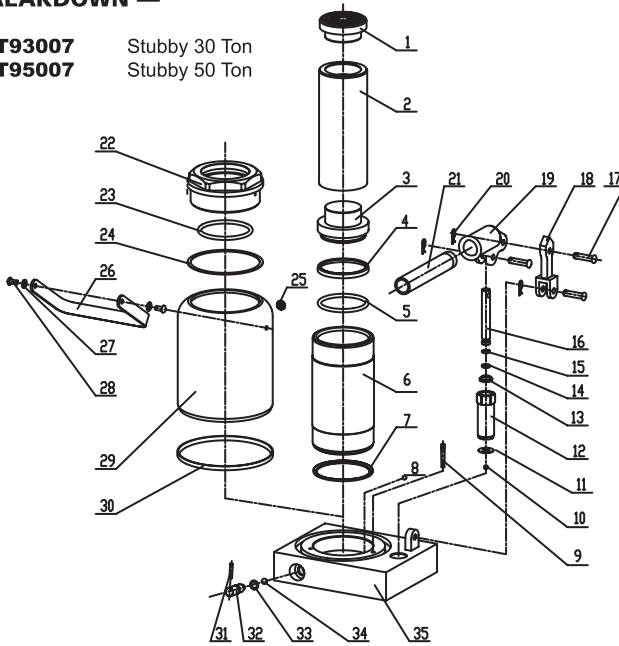

REF. NO.	DESCRIPTION	REF. NO.	DESCRIPTION
1	Saddle	18	Connecting Rod
2	Ram	19	Handle Sleeve
3	Ram Piston	20	Pin
4	Back Up Ring	21	Handle
5	O Ring	22	Top Nut
6	Cylinder	23	O Ring
7	Oil Seal Of Cylinder	24	O Ring
8	Steel Ball	25	Filler Plug
9	Filter	26	Handle
10	Steel Ball	27	Washer
11	Washer	28	Nut
12	Oil Fill Screw	29	Reservoir
13	O Ring	30	O Ring
14	O Ring	31	Pin
15	Washer	32	Release Valve
16	Pump Plunger	33	O Ring
17	Pin	34	Steel Ball
		35	Base

## SPECIFICATIONS

Model No.	T93007	T95007
<b>Capacity</b>	30 Tons	50 Tons
<b>Closed Height</b>	9-7/16"	9-5/16"
<b>Raised Height</b>	14-9/16"	14-1/16"

# TROUBLESHOOTING TIPS

Will not lift full height	Will not lower completely	Will not lift load	Pump Feels "spongy" under load	Handle raises under load	Handle lowers under load	<b>SOLUTIONS</b>
✓	✓					<b>Reservoir could be overfilled-</b> With jack upright; remove filler screw or filler plug, open release and SLOWLY push jack ram into lowered position. Any excess oil will run out fill hole. Replace filler screw or filler plug when oil has stopped flowing.
✓		✓	✓			<b>The Jack could be low on oil-</b> With jack in upright position and ram fully lowered, remove filler screw or filler plug and fill reservoir with clean hydraulic jack oil — correct oil level is reached when oil level is at bottom edge of fill hole.
		✓		✓	✓	<b>Valve might not be closing-</b> Make certain release valve is closed. Starting with ram in fully lowered position, SLOWLY raise ram out to full height. Open release valve and push ram down into lowered position. Jack should now operate properly.

**Attention:** Hydraulic oils represent a danger for the ground water. Uncontrolled draining of or improper disposal is under penalty (environmental liability law)

### Dispose of Your Used Oil

Used hydraulic oil is highly toxic to the environment and it is of the utmost importance that it is disposed of in a safe fashion. Transfer the used hydraulic oil to sealed container and consult your local garage about options for safe disposal. Chances are that a garage in your area will take the hydraulic oil off your hands and arrange for it to be recycled or safely disposed of. If, by chance, you are unable to find a garage in your vicinity willing to take your used hydraulic oil, your state / province should have an environmental agency that can direct you towards an alternative option.