



# FITTING INSTRUCTIONS

<b>Product:</b>	<b>Equipped Series Front Bumper</b>
<b>Vehicle:</b>	<b>2010-2016 Ram HD 2500/3500</b>
<b>Part No.</b>	<b>074SB17N07A</b>

- **Estimated Install Time: 3-4 Hours (two people recommended)**
- **It is advised that a minimum of two people perform the installation, so as to avoid damage to the vehicle and also reduce the risk of injury to the persons involved.**  
  
**NOTE: To achieve correct bumper fitment to body takes time by loosely fitting the winch tray and bumper to truck frame and adjusting its position slowly and carefully for the best looking finished install. To make this install easier - follow instructions completely.**
- **Where an OE component is to be removed and later reinstalled, it is recommended to take photos before removing anything to help you when reinstalling parts.**
- **Before starting installation read instructions and ensure all listed components are supplied.**
- **Left hand & right hand components are determined as seated in the vehicle.**
- **Check for (and remove) any build up in all threads fitted to the product.**
- **When fitting accessories to TJM products (ie. driving lights and aerials), ensure suitable washer plates are used under the mounting surface that allow the accessory to be secured in a way that prevents it from damaging the product.**
- **Where OE air guides require trimming, ensure minimal clearance between air guides and TJM components to prevent air leakage which may adversely affect vehicle cooling.**
- **When removing protective coatings, ensure all new edges are deburred, clean any swarf from the area and apply rust preventative to exposed surfaces.**
- **Always place the product on a soft work space to prevent damage prior to installation**

<b>Torque Table</b>	<b>Dia. (mm)</b>	<b>Nm</b>	<b>ft.lbs</b>	<b>Dia. (inch)</b>	<b>Nm</b>	<b>ft.lbs</b>
All bolt torque specs are as follows unless otherwise specified.	5	5	4	1/4"	9	7
	6	9	7	5/16"	22	15
	8	22	16	3/8"	33	27
	10	44	32	7/16"	55	43
	12	77	57	1/2"	86	66



# FITTING INSTRUCTIONS

<b>Product:</b>	<b>Equipped Series Front Bumper</b>
<b>Vehicle:</b>	<b>2010-2016 Ram HD 2500/3500</b>
<b>Part No.</b>	<b>074SB17N07A</b>

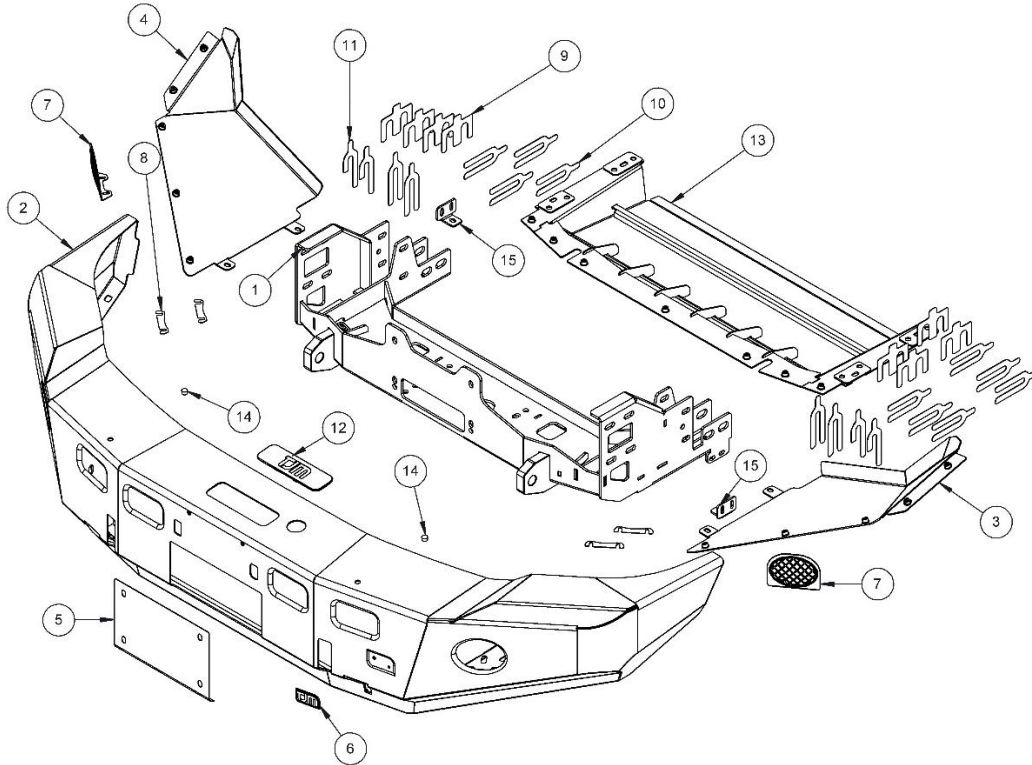

ITEM NO.	Description	Qty	Part Number
<b>PARTS LIST</b>			
1	Winch Frame with Chassis Mounts	1	DX31800
2	T17 Frontier Bumper	1	DX31000
4	Wing Guard RHS	1	DX31953R
3	Wing Guard LHS	1	DX31953L
13	Center Underguard	1	DX31901

<b>FITTING KIT</b>			
5	Fairlead Cover Plate	1	AB00100
7	Light Hole Cover Plates	2	F-12820
8	Light Cover Plate Shim	4	US-0803
9	1mm Rear Frame Shim	8	DX31970
10	1mm Inside Frame/Bumper Shim	14	DX31971
11	1mm Outside Frame Shim	4	DX31972
12	Winch Slot Cover Insert	1	92106
14	12.7mm Plastic Plug	2	K0765
15	Wing Guard Mount	2	DX31964

<b>FACTORY FITTED</b>			
6	TJM Logo Sticker	1	K3550

ITEM NO.	Description	Qty	Part Number
<b>BOLT KIT</b>			
N/A	6mm x 1.0 X 20mm Hex Bolt	4	-
N/A	6mm x 1.0 Nylock Nuts	4	-
N/A	6mm x 18 x 1.6mm Flat Washers	8	-
N/A	8mm x 1.25 x 25mm Hex Head Bolt	31	-
N/A	8mm x 1.25 Nyloc Nut	4	-
N/A	8mm Lock Washer	17	-
N/A	8mm x Ø16 x 1.6mm Flat Washer	25	-
N/A	10mm x 1.25 x 30mm Hex Bolts	10	-
N/A	10mm x 1.25mm Nylock Nuts	10	-
N/A	10mm x 30 x 3.0mm Flat Washers	20	-
N/A	12mm x 1.75 x 35mm Hex Bolt	8	-
N/A	12mm x 1.25 Nyloc Nut	8	-
N/A	12mm x 24 x 2.5mm Flat Washers	16	-
N/A	7/16-14" x1.5" Socket Head Cap Bolt	4	-
N/A	7/16-14" Nyloc nuts	4	-
N/A	7/16" x 1" x 0.080" flat washers	4	-



# FITTING INSTRUCTIONS

Product:	Equipped Series Front Bumper
Vehicle:	2010-2016 Ram HD 2500/3500
Part No.	074SB17N07A

- For all Gas Models: Follow steps 1 thru 5, 7, 15, Error! Reference source not found. thru 29 and 38 to end.
- For 2010 – 2012 Diesel Models: Follow steps 1 thru 7, 15 thru 30 and 38 thru end.
- For 2013 – 2016 Diesel Models: Follow steps 1 thru 15 and Error! Reference source not found. thru end.

***If you are not an experienced mechanic, it is highly recommended that you seek assistance from one or have the install done by an installer shop.***



1. Start by removing top plastic shield. Being careful not to damage the push in plastic clips as you will be reusing them to reinstall this part later.

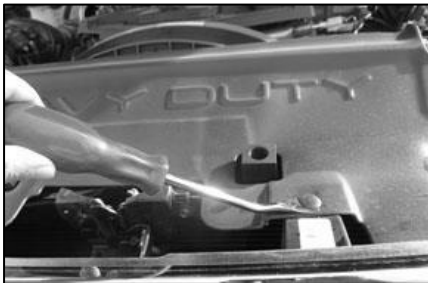

It is best to use a special fastener removal tool for this job.

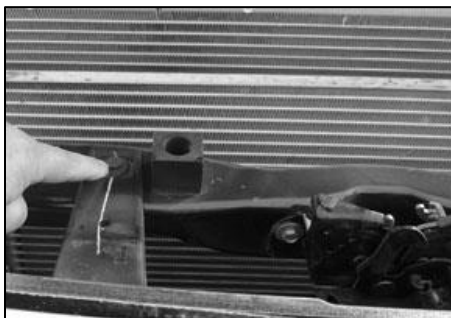

2. Remove grille from vehicle by first removing the four bolts across the top two per side.





# FITTING INSTRUCTIONS

Product:	Equipped Series Front Bumper
Vehicle:	2010-2016 Ram HD 2500/3500
Part No.	074SB17N07A

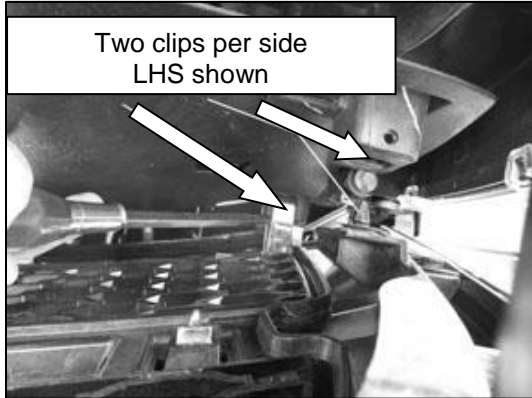

3. 2013 and newer – use caution and use a large flat head screwdriver pop the four clips loose that hold the side to the front of the radiator core support. NOTE: the earlier models only have one clip per side, located at the bottom.



4. Pull LHS fender liner out from behind bumper lip, and unplug Fog light chassis wire loom from bumper Fog light wire loom.

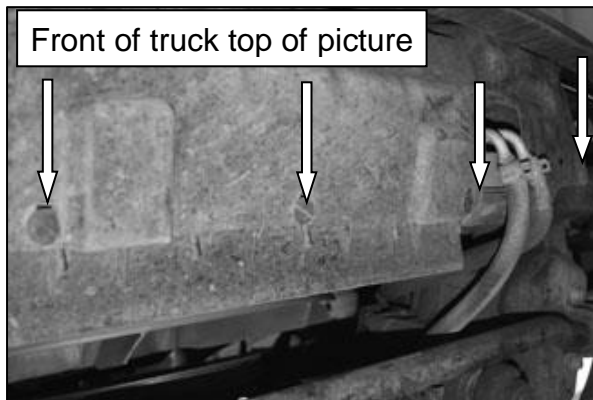

5. **NOTE: To remove bumper from 2010 -2012 Diesel** it is required to disconnect lower air duct from bumper. Carefully pop out the four plastic retaining clips using same method used for the others.

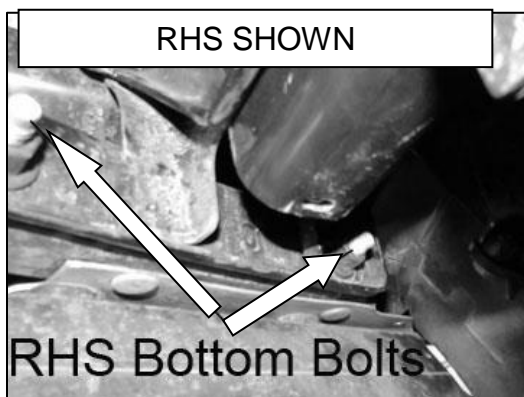

**Step 6 is for diesel models only – Gas model installers, skip to step 7.**

6. Remove front bumper from frame mounting brackets, by removing the 8 nuts holding the bumper to the brackets, (four nuts each side).



# FITTING INSTRUCTIONS

Product:	Equipped Series Front Bumper
Vehicle:	2010-2016 Ram HD 2500/3500
Part No.	074SB17N07A

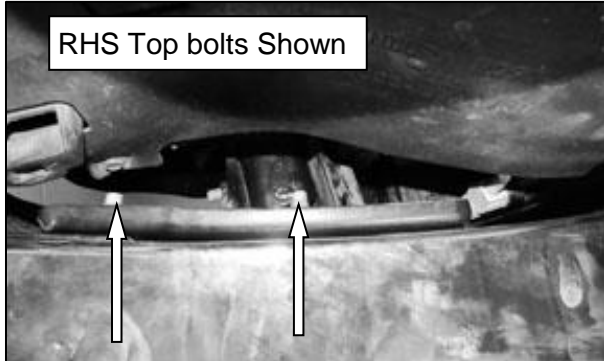

Removal of bumper skin is best done by two people working together to help insure not to damage to your vehicle. Set bumper aside.

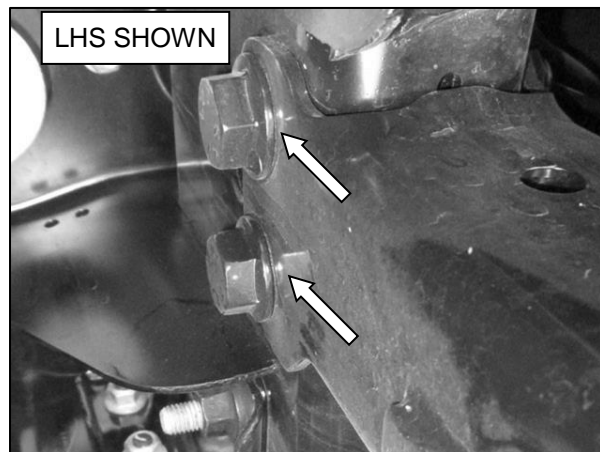

7. With a 24mm wrench and 24mm socket on 1/2" drive breaker bar, remove and discard the two lower frame extensions (i.e. 2.5" RHS hanging straight down with large black fasteners) from the frame rails. **Retain the fasteners for use in winch frame install.**

**Note:**

***These are highly torqued at factory as well as being crush style locknuts. They require significant effort to remove.***

***Note that steps 8 through to 14 and 31 through to 38, detail special instructions for owners of 2013 and newer diesel models only. These steps are required to remove the factory bumper mounting brackets and hardware.***

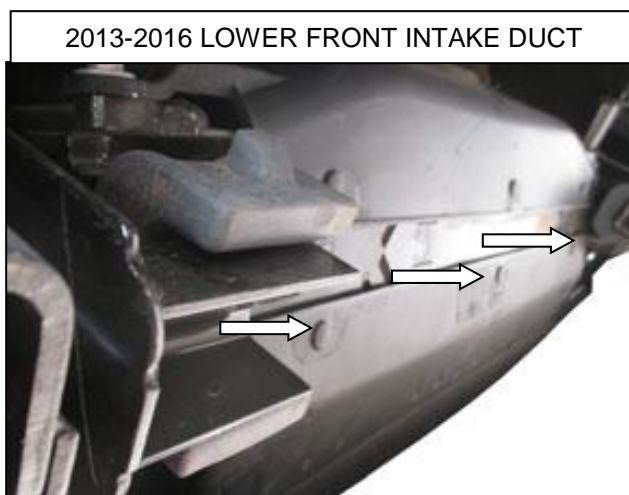

8. Remove the lower front air intake of the intercooler by first removing the three plastic retaining clips with a clip removal tool.
9. Remove the two 6mm bolts off the front of the intake bolting it to the intercooler side tanks. Lower the intake away and off the truck. Retain the fasteners and air intake.



# FITTING INSTRUCTIONS

Product:	Equipped Series Front Bumper
Vehicle:	2010-2016 Ram HD 2500/3500
Part No.	074SB17N07A

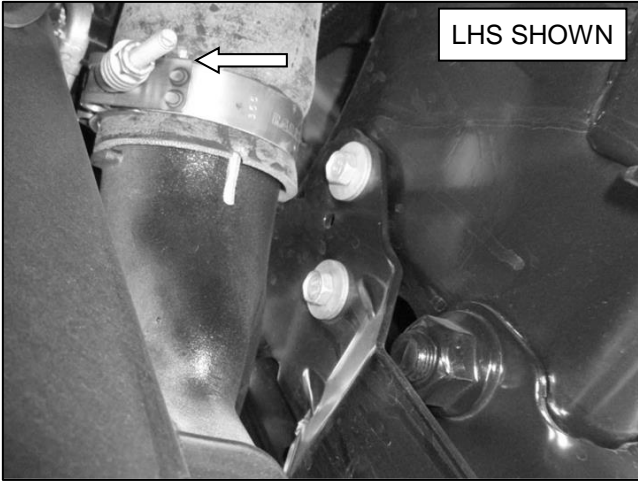

10. Loosen the lower hose clamps of the intercooler hoses; slide them up as high as possible on the hoses.



11. Work both hoses loose from the intercooler, use a large long flat bladed screw driver to carefully break the hoses loose from the intercooler flanges.

***You will not be able to completely remove the hoses off the intercooler at this time, but it is much easier to get them free from the intercooler while it is still secured to the trucks frame.***

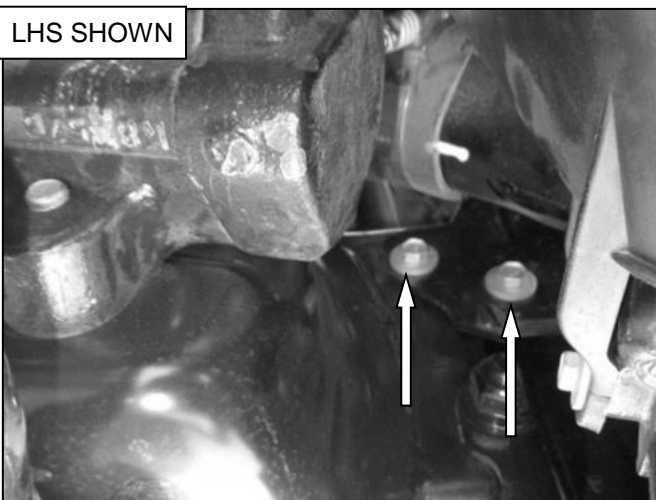

12. Loosen the intercooler mounting brackets from the chassis rail.

Note:

The LHS bracket bolts are harder to get out because of the steering box location.



# FITTING INSTRUCTIONS

**Product:** Equipped Series Front Bumper  
**Vehicle:** 2010-2016 Ram HD 2500/3500

Part No. 074SB17N07A

RHS SHOWN

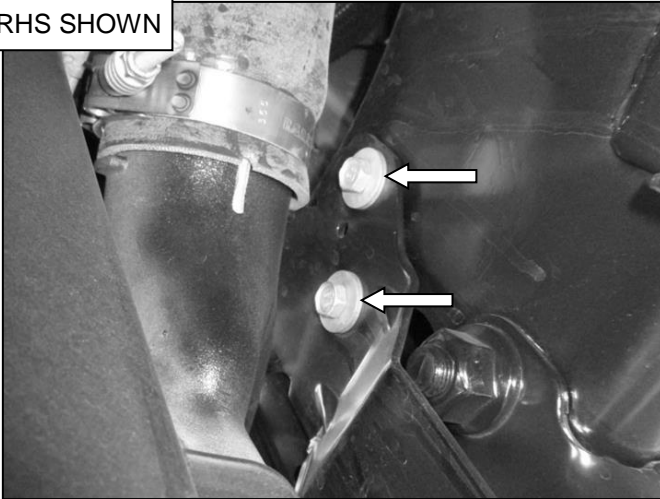

13. Retain the four fasteners from the previous step as you will reuse them to reinstall the intercooler later, now work the intercooler off the charge hoses and out of the vehicle.

14. Place the intercooler in a clean, dry area with the charge tubes facing upwards. Then, cover both charge tubes with a clean rag and ensure that no foreign matter enters them.

LHS 2013-2016 Diesel Shown

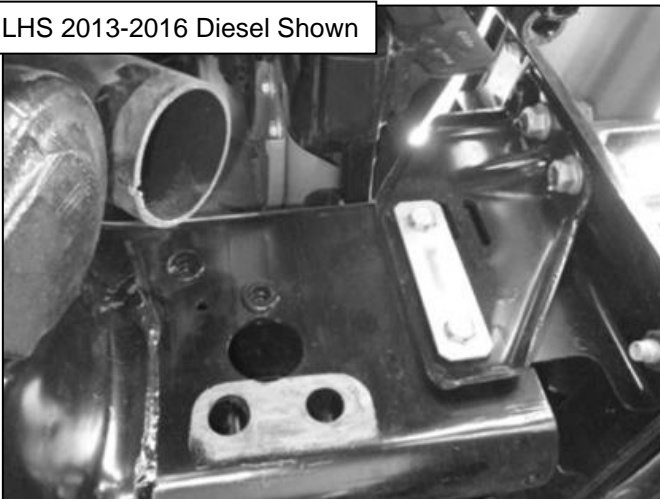

15. Remove and retain the two factory U bolts holding the bumper mounting brackets to the chassis.



2016 Ram 2500 HD Hemi Shown

**NOTE:** If you have a Gas model your bumper channel is still attached to the brackets and this operation is best preformed with three people. Two holding the bumper assembly and the third person removing the U bolts for the chassis.



# FITTING INSTRUCTIONS

Product:	Equipped Series Front Bumper
Vehicle:	2010-2016 Ram HD 2500/3500
Part No.	074SB17N07A

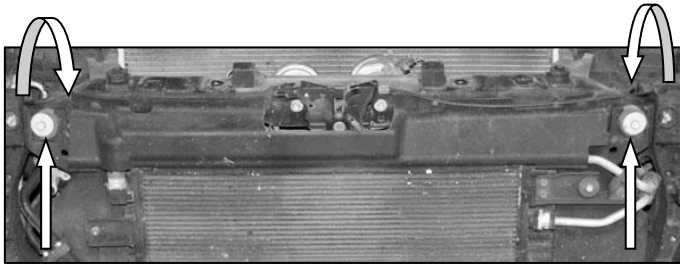

**STEPS 16 TO 21 are for 2010 to 2012 Diesel models only, to remove Intercooler & radiator for U bolt removal.**

16. Remove top two intercooler and top two radiator mounting bolts.

17. Move intercooler with top plastic cover removed. Unclip hood release cable also.

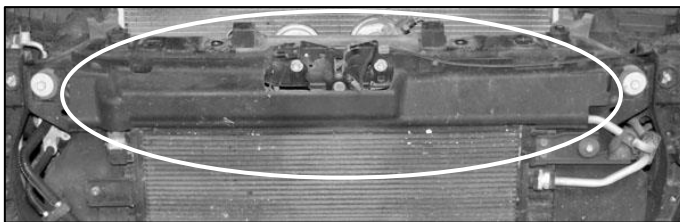

18. Wearing safety glasses to keep falling dirt out of eyes, one installer moves under the front of truck and pushes up and out on the intercooler to disengage it from the saddle mount on the outside of the tank.

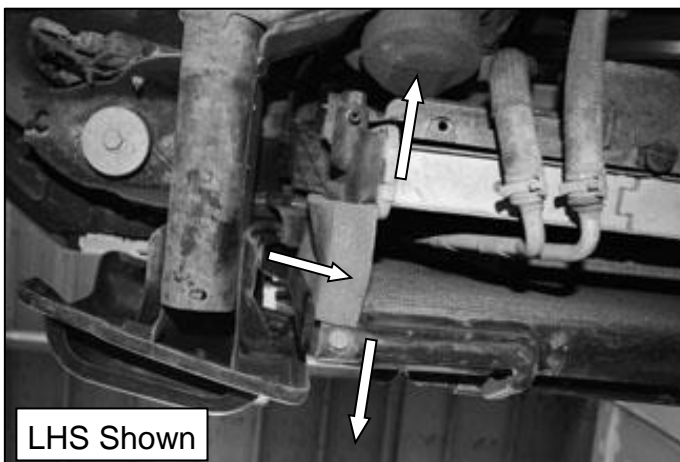

19. Repeat for the radiator pushing up and inward on the radiator.

20. When both are free of their lower saddle mounts push up and out on the intercooler and up and in on the radiator at the same time, this will create a space between the two parts so the second installer can work the bumper mounting bracket U bolts out between them to remove the mounting brackets off the chassis. Refer back to step 15.

With intercooler and radiator moved, the U bolt will slide in front of foam on radiator and between out by wiggling it around.



21. Return intercooler and radiator back into stock mounting location onto their saddle mounts, then secure them to their factory positions

NOTE for 2010-2012 diesel models ONLY, the U bolts can be reinstalled back onto truck from the outside to the inside.





# FITTING INSTRUCTIONS

Product:	Equipped Series Front Bumper
Vehicle:	2010-2016 Ram HD 2500/3500
Part No.	074SB17N07A

**Only mounting hardware from the removed OE bumper is required to install the TJM Winch Frame Assembly.**

The following steps Error! Reference source not found. thru 29 are for all models of the 2010 – 2016 Ram HD.

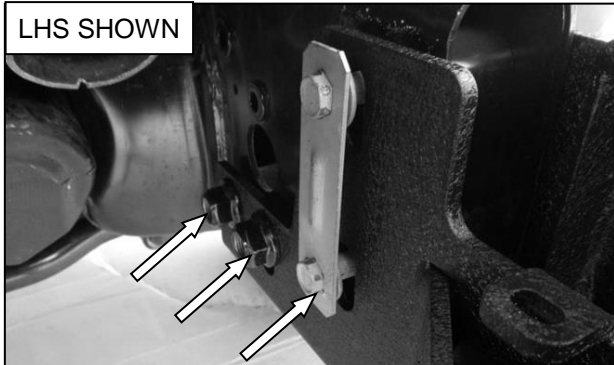

2013-2016 Diesels U bolts go inside to outside or they will touch intercooler tanks.

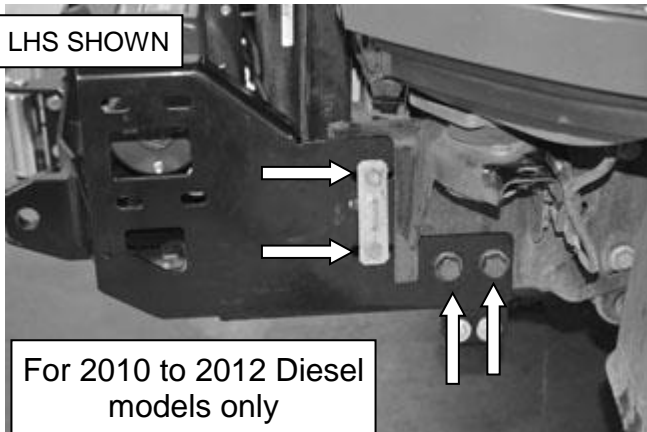

For 2010 to 2012 Diesel models only



**The steps Error! Reference source not found. thru 24 are best performed with two persons supporting either side of the TJM winch frame and a third installing the hardware.**

22. Fit winch frame using factory hardware. Install U bolts from the inside of the chassis facing outwards.

NOTE: that on 2010-2012 diesel models, the U bolts can be reinstalled on the truck outside / in.

23. With the winch frame positioned near the center of the mounting slots in the winch frame mounting brackets finger tighten the nuts on the U bolts until the washers touch the inner bracket.

24. Place the large 24mm” head bolts at rear in stock locations.

25. You will notice gaps between the outsides of the factory chassis and your TJM Winch Frame, these gaps are designed to aid in fitment due to build variances in the truck and winch frame.

**Note that the bodies are not always perfectly centered on the chassis.**

Center the TJM Winch Frame to the trucks body, by using some combination of the supplied shims. Placing shims between all sides on the chassis rails and the Winch Frame brackets.

**This process is very helpful in getting the bumper centered to the vehicle’s body.**

26. Using a framing square, slide square to RHS inner bracket of the recovery system and measure distance to the inside lower corner of



# FITTING INSTRUCTIONS

<b>Product:</b>	<b>Equipped Series Front Bumper</b>
<b>Vehicle:</b>	<b>2010-2016 Ram HD 2500/3500</b>
<b>Part No.</b>	<b>074SB17N07A</b>

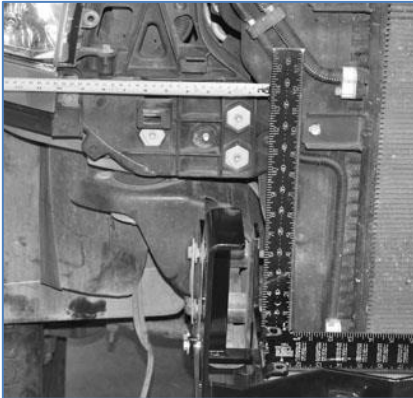

the head light. Repeat this process on the LHS of your truck. As close as possible center the winch frame to the body's location on the frame.

**Shims ITEM # 11** long two equal legs go to the inside of the trucks frame rail – at U bolt location.

**Shims ITEM# 12** Long – with one short leg and one long leg go to the outside of frame rail **SHORT LEG FORWARD** – at U bolt location.

**Shims ITEM # 13** Wide double slotted go to the inside and out side in rear at the Large through bolt loactions.

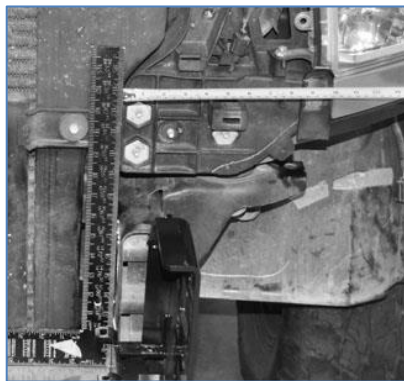

27. Start on the side of vehicle that you slide the winch frame over in order to get close to centering it to body. On outside of frame, put as many ITEM # 12 shims (with short leg forward) as you can fit into the space between chassis and winch frame without moving it by doing so.

28. Put the same number of ITEM# 11 shims on the inside of the opposite side of vehicle. Use remaining #12 shims to fill on other side in the outer gaps at U bolts

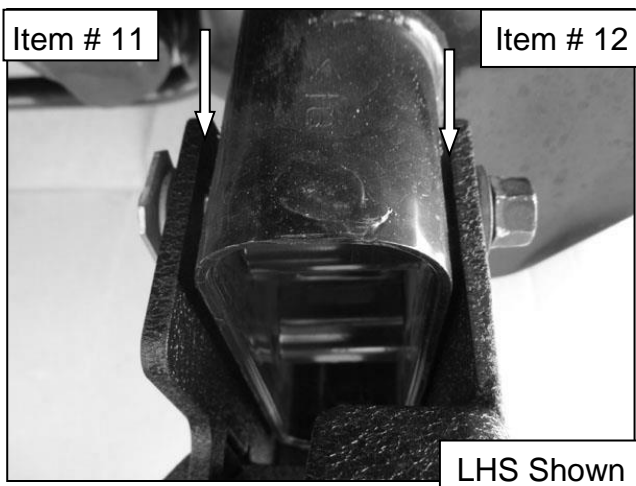

**NOTE:** It is important that you fill these gaps as much as possible.



# FITTING INSTRUCTIONS

Product:	Equipped Series Front Bumper
Vehicle:	2010-2016 Ram HD 2500/3500
Part No.	074SB17N07A

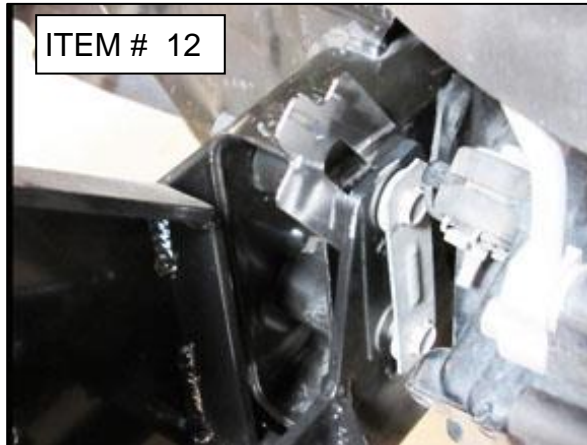

- For Winch Frame to function as designed, the brackets need to pinch the vehicle chassis tightly when torqued down.

29. Position the same combinations of Item#13 shims inside and outside at the rear set of fasteners.

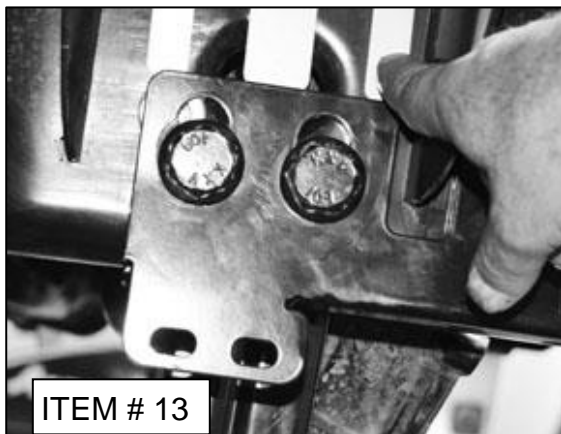

**2013 – 2016 Diesel - It is best to not reinstall the lower front air intake of the intercooler is doing so with the winch frame in position could limit the air going through it. The TJM Center Underguard has an intake opening in it and act as skid plate for the intercooler.**

**Steps 30 through 37 are specific for 2013-2016 Diesel models only.**

30. 2013-2016 Diesels - Reinstall the intercooler to its original position.
31. Position the hose clamps over the hoses and slide them up high and out of the way. Pay attention to the positioning of the clamps.
32. Slide the intercooler up into position, lining up the charging hoses on both sides together.
33. With both hoses started correctly on the intercooler tubes, work together and push the intercooler up and into position fully.

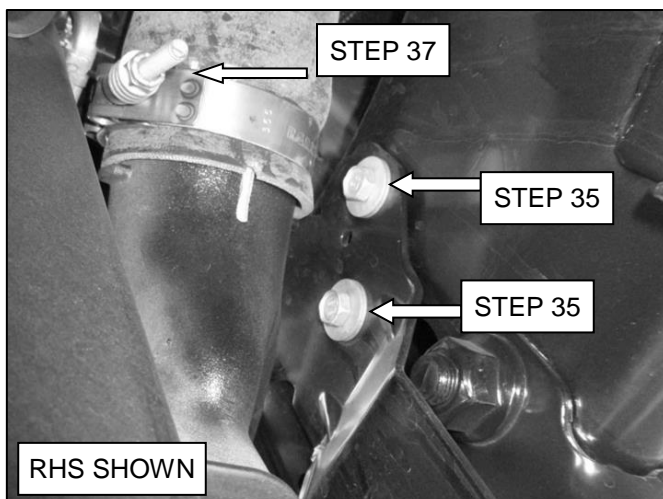



# FITTING INSTRUCTIONS

Product:	Equipped Series Front Bumper
Vehicle:	2010-2016 Ram HD 2500/3500
Part No.	074SB17N07A

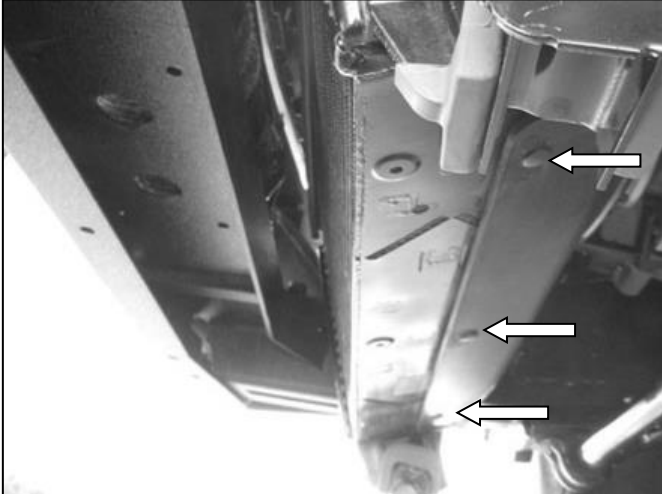

34. Reinstall the intercooler mounting brackets to chassis rails using the four factory fasteners from step 10 - 11.

*Ends of fasteners have 1/4" with no threads, so you have to get the fasteners in about 3/8" to actually start rethreading.*

35. Easiest for two installers to work together to get rubber tubes fully back down and over the intercooler inlet and outlet tubes.

36. Slide the two charge hose clamps down into their original positions and tighten them back up.

37. Reinstall the factory intercooler's lower rear fan shroud, using the three plastic clips removed earlier.



All steps forward are the same for all models 2010 to 2016.

38. Install a winch (sold separately) at this time.

Designed to accommodate a Warn 16.5Ti  
Follow your winch manufactures install instructions for mounting and wiring.



39. SPECIAL NOTE TO WARN 16.5Ti USERS: The disengaging leveler needs to be clocked as seen in picture to left before installing. Failure to do so will result in the bumper channel not fitting over the winch.

40. Do not install fairlead at this time – installs at step #72.

**NOTE: Wire and fully test the function of your winch before proceeding with the further install of your new TJM Bumper Channel.**



# FITTING INSTRUCTIONS

Product:	Equipped Series Front Bumper
Vehicle:	2010-2016 Ram HD 2500/3500
Part No.	074SB17N07A

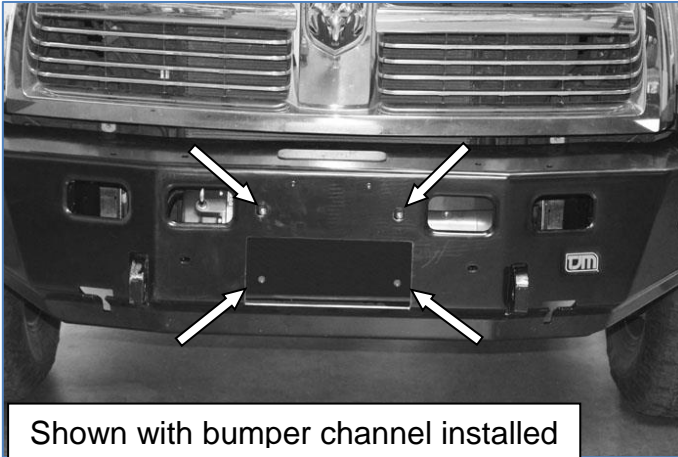

41. To insure you can position and adjust bumper on winch frame as desired – use the two supplied 7/16” socket head bolts for the top two holes for mounting winch to winch frame front plate. Do not use any flat washers here.

42. If you choose not to install a winch at this time, install the winch frame front face cover plate (ITEM#9) using the supplied 7/16” Socket Head Cap screws and Nylock nuts.

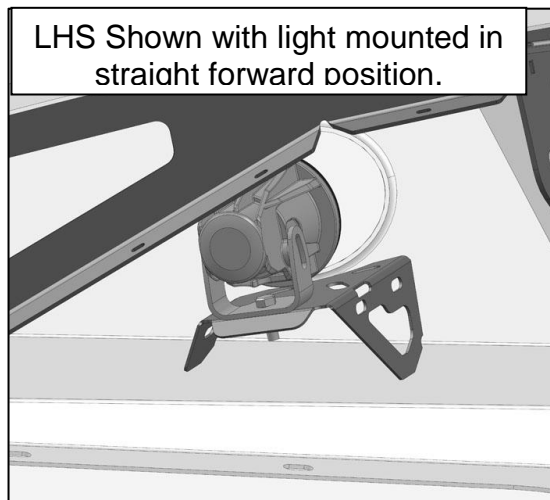

*Auxiliary Light mounts in TJM Bumper Channel*

43. Install any auxiliary inside fitting road lights you may have purchased now. Refer to your light manufactures install and wiring instructions.

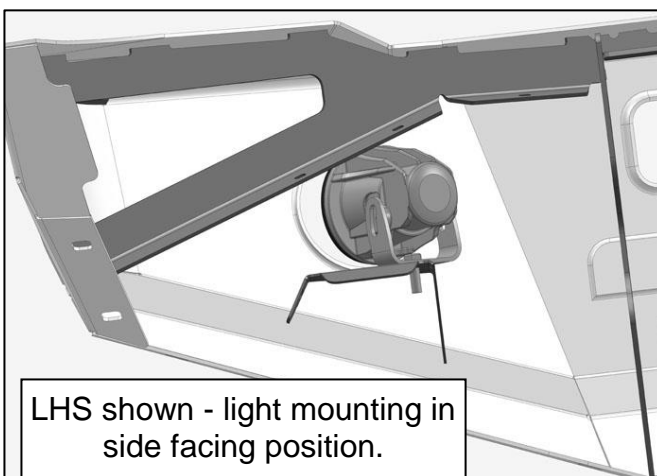

**SPECIAL LIGHT MOUNTING FEATURE:**  
The light mounts in your NEW bumper channel have been designed with two large slots for the mounting of auxiliary lights. One is facing front to back for illuminating the road directly in front of the truck. While the other is at an angle perpendicular to the wing faces and offset slightly to the inside of the bumper channel. This position is for illuminating the side of the road in front of the truck.



# FITTING INSTRUCTIONS

Product:	Equipped Series Front Bumper
Vehicle:	2010-2016 Ram HD 2500/3500
Part No.	074SB17N07A

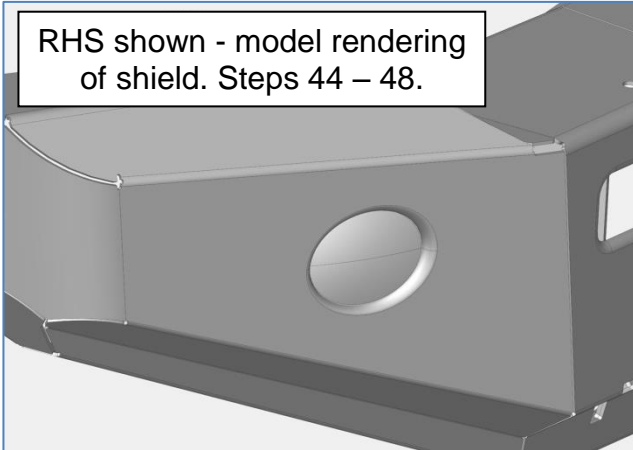

- 44. --
- 45. Fit fog Light grilles using M6 hardware
- 46. --
- 47. --
- 48. --

49. Apply painter's low tack type to the front of the truck fender liners at this time. RHS Shown.



***Placing bumper channel on vehicle is best performed with three persons. Two holding either side of the bumper, while the third installs hardware.***



- 50. Carefully move the bumper over the winch / winch frame, taking care not to damage the bumper or the vehicle.
- 51. Using the eight 12mm x 1.25 x 35mm hex bolts, sixteen 12mm flat washers & eight 12mm Nylock hex nuts, secure the bumper to the winch frame, as shown, finger tight only.



# FITTING INSTRUCTIONS

<b>Product:</b>	<b>Equipped Series Front Bumper</b>
<b>Vehicle:</b>	<b>2010-2016 Ram HD 2500/3500</b>
<b>Part No.</b>	<b>074SB17N07A</b>

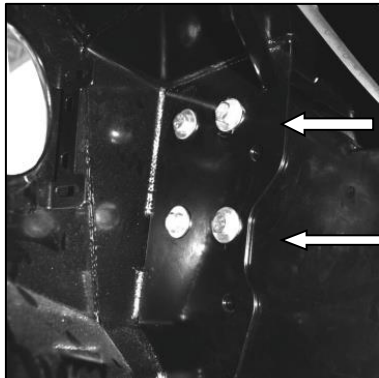

Extra #11 Shims slide in here

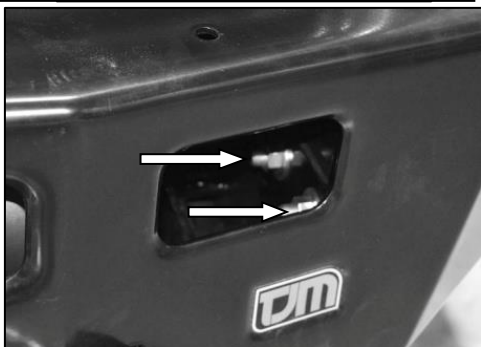

12mm hardware attaching bumper

52. Extra ITEM# 11 shims have been included for holding a side to side adjustment of the bumper to winch frame. Slide shims in as needed between winch frame and bumper to center bumper to body. Measure top of wing tips to body both sides and adjust until equal.

53. Tighten up two sets of 12mm hardware per side once shims are in, but not so you cannot adjust the bumper on the winch frame.

54. Stand back and look at the bumpers fitment with the truck's nearby body panels. From front and side until you are satisfied with the fitment before torquing down any hardware.

Bumper to winch frame fit has been designed, so as to not need to fit right up against each other. This allows for a twisting adjustment of the bumper to align the top of the bumper wing with the bottom of the truck head light.



Maintain equal distance from these points around to tips of wings both sides.

**55. MAINTAIN A MINIMUM CLEARANCE OF 3/4" BETWEEN TOP OF BUMPER AND ALL MATING BODY PANELS OTHERWISE BODY AND BUMPER DAMAGE MAY OCCUR.**

Because the winch frame is still loose on the chassis, moving it in or out will aid with bumper channel adjustment in and out also.



In this picture RHS of bumper wing tip is 1/8" below bottom of body – on level ground it is 7/8" below. This is due to body to chassis twisting in rubber body mounts.



# FITTING INSTRUCTIONS

Product:	Equipped Series Front Bumper
Vehicle:	2010-2016 Ram HD 2500/3500
Part No.	074SB17N07A



2011 Diesel LHS Shown

56. Once you are satisfied with your TJM bumper's fit on your truck, fully torque down the two large bolts at rear of WINCH FRAME to chassis only.

**The following steps are very important and will pin the Winch Frame to chassis and pin bumper channel to the Winch Frame. By drilling the open holes in each side with a 7/16" drill bit.**

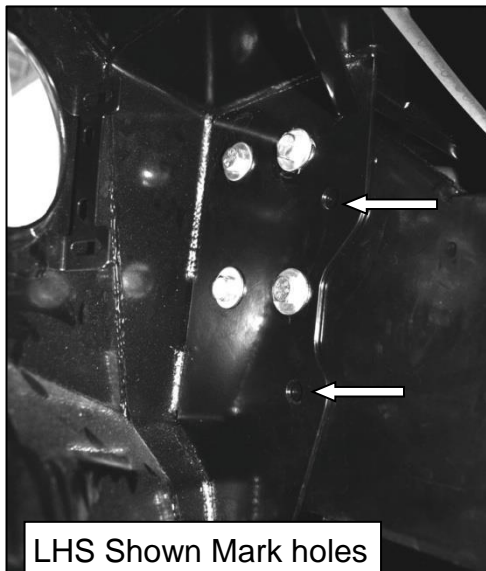

LHS Shown Mark holes

57. Take special care to carefully mark thru the holes onto the winch frame on both sides through the unused holes in the rear of bumpers mounting plates.

58. If you have a 90 degree drill that fits you may want to start drilling these holes with bumper in place using it as a drill jig to mark the holes. Bumper channel must still be removed from truck.

**Removing and reinstalling the bumper is best performed by three people.**

59. Retaining all of the fasteners, carefully remove the TJM bumper from the winch frame and gently place it aside, taking care not to damage the vehicle or the TJM bumper.

Take note of positions and quantities of shims used between Winch frame and bumper mounts so you can replace them in the same way later.





# FITTING INSTRUCTIONS

Product:	Equipped Series Front Bumper
Vehicle:	2010-2016 Ram HD 2500/3500
Part No.	074SB17N07A

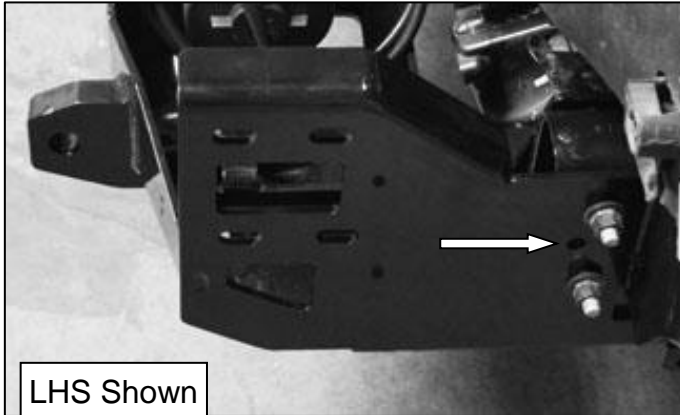

60. With bumper off winch frame, pin your TJM winch frame to chassis, by using a 7/16" drill bit, drilling thru the two, one per side, 10mm/7/16" holes in outer winch frame mount.

61. **On 2010 – 2012 Diesel models**, Start on RHS and remove U bolt from winch frame. Drill hole and install 10mm hardware and torque down. Then refit U bolt as installed before, as you torque down the nuts for the u bolt you will notice the strap will deform, this is ok as the bolts will still function as needed.

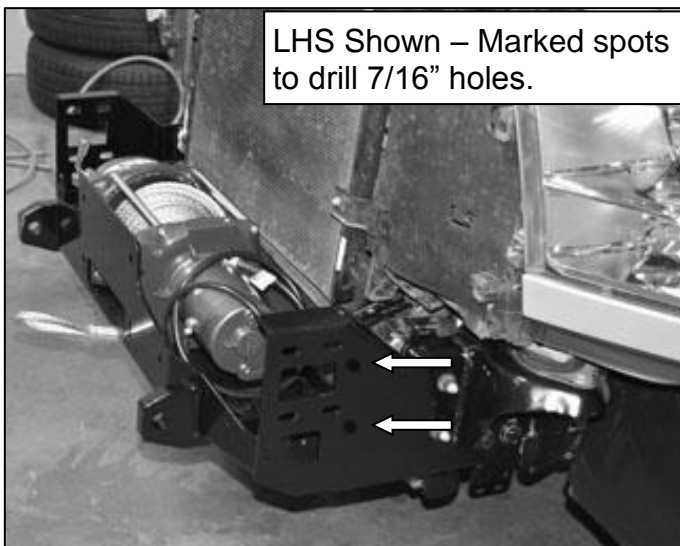

62. **2010-2012 Diesel models**, repeat step 61 on LHS.

63. All other models, use one set per side, two of the supplied 10mm x 1.25 x 30mm Hex bolts, four 10mm flat washers & two 10mm Nylock hex nuts, secure the winch frame to the chassis through holes you just drilled.

64. Pilot drill the four holes you marked on winch frame, two per side, while bumper was on. Then drill them out to 7/16".

65. Debur the holes & clean the area/surface of any sharp edges. Then treat the raw exposed surfaces with a rust preventative.

66. Torque down this 10mm hardware and the nuts on the factory U bolts as spec'ed on first page at this time.

67. Torque down factory nuts on factory U bolts.

**By drilling these six holes and installing the M10 hardware you have insured your winch frame to chassis and bumper channel to winch frame position will stay as installed during future off-road use and recovery operations.**



# FITTING INSTRUCTIONS

Product:	Equipped Series Front Bumper
Vehicle:	2010-2016 Ram HD 2500/3500
Part No.	074SB17N07A



Shown with TJM HD D-Rings

68. Carefully reposition bumper on winch frame, replace 12mm hardware and shims. Only finger tighten at this point.

69. Per side use two of the supplied 10mm hex bolts, four 10mm flat washers & two 10mm Nylock hex nuts, to secure bumper to winch frame thru these holes.

70. Once you have all four sets of 10mm hardware installed, torque down the four sets 10mm hardware.

71. Now torque down 12mm hardware holding the bumper to the winch frame. Torque to specs listed on page one.

72. Install fairlead directly to the face of the Winch Frame - in the case of the Warn 16.5 Ti the lower two bolts supplied with winch that attach winch to front face of Winch Frame are used for fairlead.

73. If mounting a set of top lights or light bar. Mount them now. Refer to light manufactures mounting and wiring instructions.

74. At this time wire and test all your lights to switches for proper functioning of lights, before proceeding.

75. Adjust the inside bumper lights as needed to achieve desired forward or side lighting.



# FITTING INSTRUCTIONS

Product:	Equipped Series Front Bumper
Vehicle:	2010-2016 Ram HD 2500/3500
Part No.	074SB17N07A



76. Find and mount RHS underguard rear support bracket in rear on outside of winch frame. With 90 degree bent leg facing center of vehicle. Use supplied, two 8mm hex bolts, four 8mm flat washers and two 8mm Nylock nuts. Leave hardware loose so bracket can be adjusted on the winch frame.

77. Repeat step 57 to install the LHS rear underguard support bracket.

78. If not already done, use painter's low tack type, tape off fronts of fender liners as shown.



79. Place a sharpie pin under truck on one side for use later.

**The center underguard is designed to act as an air intake and skid plate to protect the 2013 / 2016 diesels low hanging intercooler.**

**Steps 72 through the rest of the install are best performed by 2 persons one per side.**

80. Place the RHS & LHS wing underguard assemblies in front of tires so it can be reached while lying under the truck. Also place 8mm & 10mm hardware for installing underguards to bumper. Seventeen M8 hex bolts, seventeen 8mm flat washers and seventeen 8mm lock washers. Four 10mm hex bolts, eight 10mm flat washers and four 10mm Nylock nuts.

81. Now with two persons, take center underguard assembly and move under the front of truck. Slide the front of the center section up and on top of bumper bottom inside surface.

82. While one installer supports the rear of underguard the other person installs one 8mm hex bolt, 8mm lock washer and one 8mm flat washer in their sides outer most hole of underguard. Loosely inserting hardware through bumper and into nut insert in the underguards assembly.

83. Repeat step 80 to 82 reversing jobs to install outer 8mm hardware on opposite side.





# FITTING INSTRUCTIONS

<b>Product:</b>	<b>Equipped Series Front Bumper</b>
<b>Vehicle:</b>	<b>2010-2016 Ram HD 2500/3500</b>
<b>Part No.</b>	<b>074SB17N07A</b>



84. Now loosely install five sets of 8mm hardware into the remaining holes of the center underguard.

85. Torque down all 8mm hardware in center section of underguard to specs listed page one.



86. While one of the installers supports the rear of the center underguard assembly, the other installer slides their side's wing underguard up on top of the bumper wing's bottom lip.

87.--

88.-

89.-

90.-

91. Position and align bolt holes on the side under panels. Mark fender liner to be cut as shown.

92. Repeat for other side.





# FITTING INSTRUCTIONS

**Product:** Equipped Series Front Bumper  
**Vehicle:** 2010-2016 Ram HD 2500/3500

**Part No.** 074SB17N07A

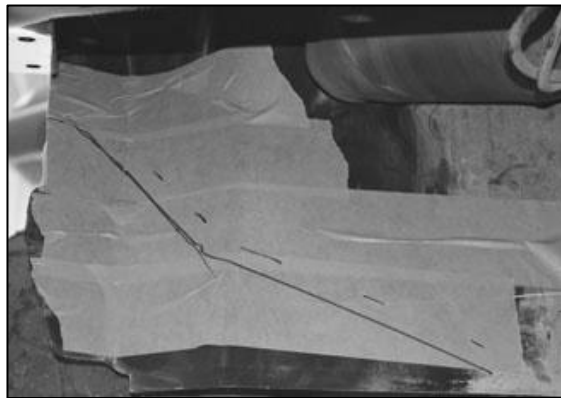
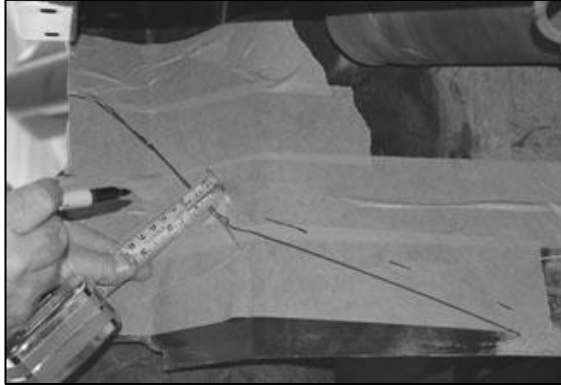

93. Remove wing underguards from truck. And as shown mark a lines  $\frac{1}{2}$ " to  $\frac{5}{8}$ " above the lines traced off the wing underguards.

94. Fill in between the marks and trim plastic fender liners with available cutting tool and clean up edges.

**During the next few steps make sure the inner fender wells stay outside of and behind the bumper & wing underguard rear lips as you will need to fold them back and out of your way to reach inside with tools.**

95. Reinstall the wing underguards by loosely installing all 8mm hardware for wing underguard to bumper attachment.

96. Install 10mm hardware up and through the front wing tabs to center section. Using one 10mm hex bolt, two 10mm flat washers and one 10mm Nylock nut per side.

97. Install the 10mm hardware through the rear tabs up through center section and into the rear support brackets, as before.

98. With all 8mm & 10mm hardware loosely in place, start with the inner most 8mm bolt of wings moving outward torquing down 8mm hex bolts.

99. Reaching thru center section outer air intake, torque the front 10mm hardware per specs on first page.

100. Now torque 10mm hardware securing rear of underguards to rear support brackets.

101. Adjust rear support brackets to position underguards as needed and torque down 8mm hardware attaching them to winch frame.

102. Twist and push the trimmed fender liners inside the return folds of the bumper wing tips and wing underguards.

103. --



# FITTING INSTRUCTIONS

<b>Product:</b>	<b>Equipped Series Front Bumper</b>
<b>Vehicle:</b>	<b>2010-2016 Ram HD 2500/3500</b>
<b>Part No.</b>	<b>074SB17N07A</b>

## Finished installs 2011 Ram Diesel



## 2016 Ram Diesel

