

TITAN pt. no.: 01 0000 0175

Important: Please read these instructions carefully and completely before starting the installation.

TITAN Fuel Tanks

INSTALLATION INSTRUCTIONS

Gen6



Extended Capacity Replacement Tanks for GENERAL MOTORS (Chevrolet and GMC) Diesel Trucks

7010220: 56* Gallon (211* liters) Replacement Tank for 2020+ GM truck models 2500 HD & 3500 HD : Crew Cab Short Bed (6 ½ ft.)

Required Tools:

- 1 ea. Ratcheting socket driver
- 1 ea. 13 mm socket
- 1 ea. 12 inch long socket driver extension
- 1 ea. 8 mm end wrench
- 1 ea. 8 mm socket
- 1 ea. 9/16 inch socket
- 1 ea. 9/16 end wrench
- 1 ea. Medium flat blade screw driver
- 1 ea. Needle nose pliers
- 1 ea. Torque wrench handle for socket
- 1 ea. Mallet or small hammer
- 1 ea. Razor blade or sharp bladed knife.
- 1 ea. Hook pick or small ice pick
- 1 ea. Diagonal Cutters

Recommended Optional Tools:

- 1 ea. Transmission jack
- 1 ea. Vehicle hoist
- 1 ea. Impact wrench

7010220 Crew Cab, Short Bed Identification and Parts List:

1ea. Extra heavy-duty, 56* gallon, cross-linked polyethylene (XLHDPE) fuel tank for one of the following General Motors diesel trucks:

Crew Cab, Short Bed 2020

Gen6

Tank Identification: "2020 GM CCSB"

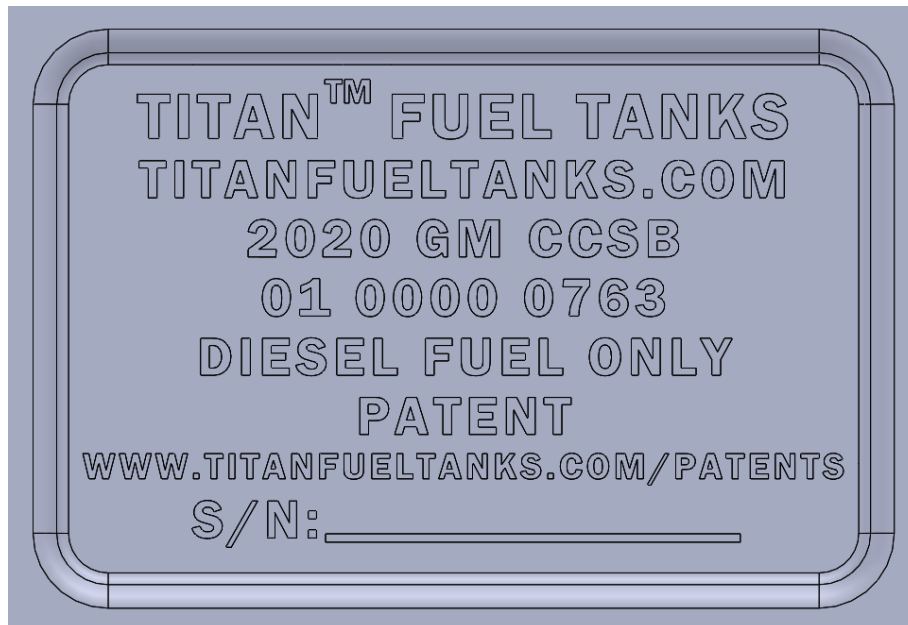

Note: Each tank has the above identification on its bottom. Please check to be sure the tank is properly identified as the one to fit your vehicle.

<u>No.</u>	<u>Part Number</u>	<u>Part Description</u>	<u>Qty.</u>
1	01 0000 0763	Tank Body (XLHDPE)	1
2	01 0121 0000F	Front Strap	1
3	01 0121 0000R	Rear Strap	1
4	02 0000 0197	TITAN Orange O-Ring	1
5	99 0186 0000	TITAN Rollover Vent	1

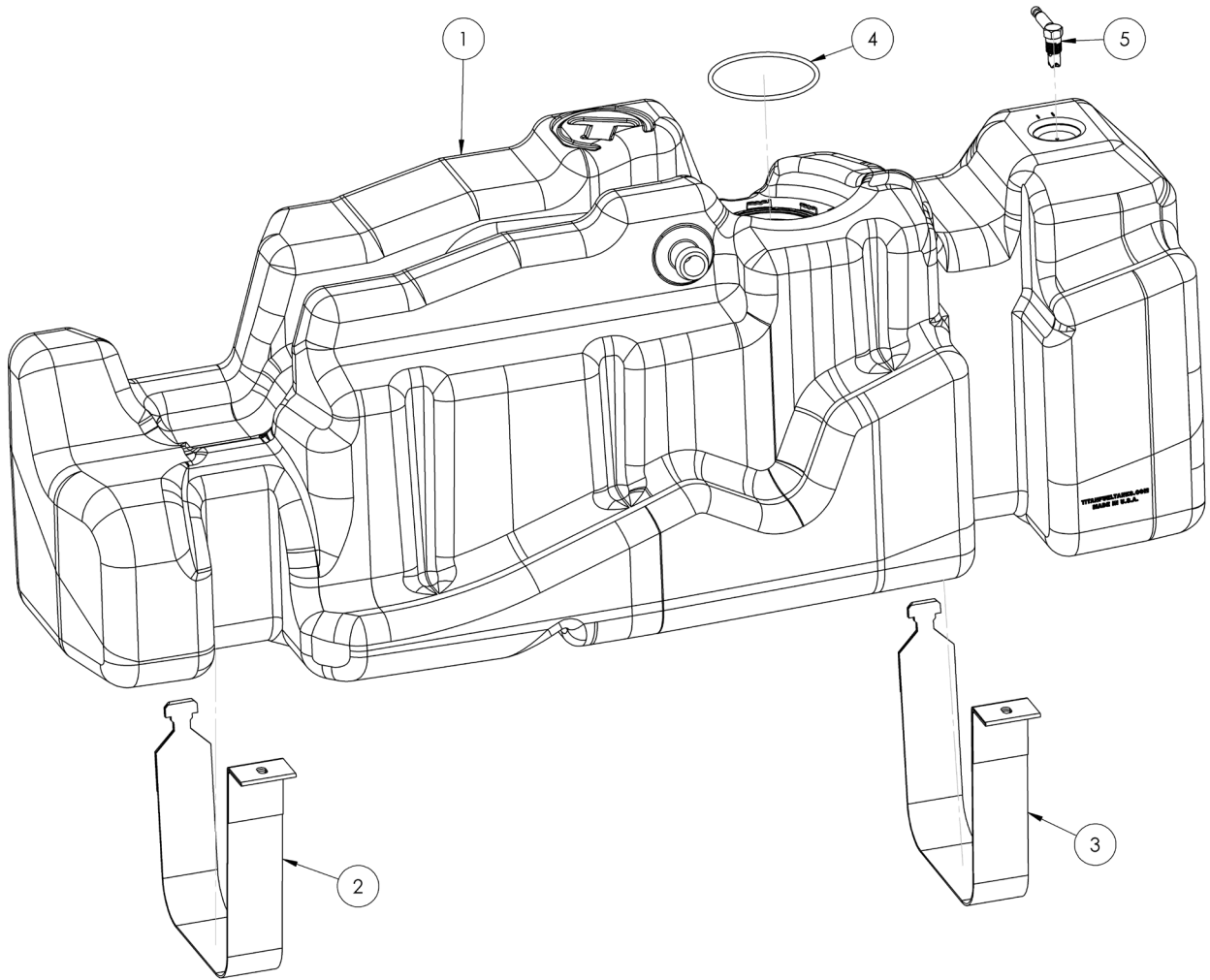

IMPORTANT NOTICE: Before installation, be sure to thoroughly inspect inside of the tank for ANY foreign debris!

I. Remove Original Equipment Tank

Step	Description
1	Place the vehicle on a hoist that leaves the entire underside of the frame unobstructed.
2	Drain all the fuel from the original equipment (OEM) tank using a TITAN Fuel Caddy, pump or siphon.
3	Remove OEM tank plastic shield or shell (if applicable) from vehicle.

- 4 Support the OEM tank.
- 5 Disconnect the fill hose from the OEM tank's king nipple.
- 6 Disconnect fuel lines at the front of the OEM tank (see Fig. 1). Leave fuel lines in place, for the moment, on top of OEM tank.
- 7 Loosen and remove OEM tank straps by undoing the bolts at outside of tank and unhook straps on the inside and lower tank a few inches.
- 8 Disconnect vent line hose from sending unit at the top of the tank.
- 9 Disconnect fuel gauge electrical connection from sending unit.
- 10 Remove the OEM tank from the vehicle.

II. Prepare Vehicle and Replacement Tank

Step	Description
------	-------------

- | | |
|----|---|
| 11 | Use hook pick or small ice pick to disconnect the fuel lines from the sending unit (See Fig. 2). Remove the fuel lines from the top of the OEM tank. |
| 12 | Use a mallet and screw driver or punch to loosen the OEM hold-down ring on the sending unit by tapping it and turning it counter-clockwise (See Fig. 3). Remove the sending unit from the OEM tank. Do NOT reuse factory O-ring seal. |



(Fig. 1) Disconnect fuel lines at the front of the OEM tank.



(Fig.2) Disconnect fuel lines at the sending unit using pick.



(Fig.3) Loosen hold-down ring on OEM tank by tapping counter-clockwise, remove and lift out sending unit.

- 13 The new TITAN fuel tank comes with the sending unit O-ring gasket packaged separately or included in the envelope with the instructions. Place the new O-ring into the gland (groove) on the new tank.
- 14 Carefully place the sending unit into the new TITAN replacement tank. Make sure the O-ring gasket is placed properly under the sending unit to seal correctly. Before installing the sending unit into the replacement tank, BE SURE THE INSIDE OF THE TANK IS FREE OF DIRT OR DEBRIS OF ANY KIND.
- 15 Make sure the tab on the sending unit is lined up with the "Tab Location" mark on the TITAN tank (see Fig. 4).
- 16 Place the original equipment, top hold-down ring onto the lugs and the sending unit and turn it clockwise as far as it will go (see Fig. 5).
- 17 Retrieve the fuel lines from the OEM tank and attach the suction and return fuel lines to the sending unit which is now installed in the replacement tank. After attaching them to the sending unit, lay the fuel lines into the fuel line groove provided in the top of the replacement tank (See Fig. 6). If desired, it is good practice to tie the two lines together with snap ties.

III. Install Replacement Tank in Vehicle

Step	Description
------	-------------

- | | |
|----|---|
| 18 | The TITAN tank straps will reuse the original equipment mounting brackets and bolts. Hang the inboard side in the brackets first. |
| 19 | Place tank on a transmission jack. Then lift the tank high enough to reconnect the sending unit electrical connection and the vent hose to the sending unit (See Fig. 7). |

- 20 Once all connections are securely attached, lift the tank the rest of the way into place with the jack.
- 21 Attach the fill hose to the king nipple on the replacement fuel tank and clamp tightly. Reconnect the fuel lines at the top front of the tank.
- 22 Finish attaching the tank straps and tighten them to OEM specifications.
- 23 Make sure ALL mounting hardware, clamps, bolts, etc. are properly installed and TIGHT. Double check it.
- 24 Lower vehicle, fill tank with diesel fuel (do not “top off”) and check for leaks.



(Fig 4) Line tab on sending unit up with “Tab Location” marks on the TITAN tank.



(Fig. 5) Tighten the top TITAN Torque hold-down ring onto the sending unit by turning it clockwise as far as it will go.



(Fig. 6) New TTITAN tank with fuel lines connected to the sending unit and in place.



(Fig. 7) Lift tank high enough to reconnect electrical cable and vent hose to sending unit.

* All capacities are approximate