



FOR DIESEL FUEL ONLY TITAN pt. no.: 99 0000 0758

Important: Please read these instructions carefully and completely before starting the installation.

TITAN Fuel Tanks™

INSTALLATION INSTRUCTIONS

TRAVEL TREKKER™

Travel Trekker™, 50 Gallon, In-Bed Auxiliary Fuel System* Model 5410050



Congratulations! You have purchased the finest in-bed auxiliary fuel system on the market. It has been designed to be attractive, durable and simple to install. It is baffled to minimize fuel sloshing and its compact dimensions (17.5" deep, 60" wide at top and 50" at bottom, with 19" height) allow it to be installed in most full-sized pickup truck beds without interfering with most hitches and conventional tonneau covers. With one touch, fuel transfers from the Travel Trekker™ to the vehicle's primary fuel tank and continues to flow until it is automatically stopped by the controller or the button is touched again. The electronic controller indicates the fuel level in the auxiliary system at all times.

The durability of TITAN's fine military grade, cross-linked polymer tank products is legendary. We routinely test our tanks using state-of-the-art computer simulations as well as actual drop tests. We fill our tanks completely and drop them 30 feet onto a steel plate--never losing a drop of liquid. There are no welds to fail. If you ever accidentally run your gooseneck hitch into your Travel Trekker™ you will most likely find it springs right back. Soap and water and a little bit of Pledge® furniture spray, or Armor All® Protectant will keep your tank looking brand new.

* U.S. Patent No. 9174528

Travel Trekker™ Meets DOT FMCSA Title 49 Requirements

Required Tools:

- 1 ea. Power drill, electric or air powered
- 1 ea. 7/16" Drill Bit
- 1 ea. 3/4" Drill Bit
- 1 ea. 1/2" Drill Bit
- 1 ea. Medium Phillips Screw Driver
- 1 ea. 9/16" End Wrench
- 1 ea. Ratcheting socket driver
- 1 ea. 9/16" Socket
- 1 ea. Tape Measure
- 1 ea. Torque Wrench
- 1 ea. Wire Stripper
- 1 ea. Wire Connection Crimper
- 1 ea. Small Propane Torch or Cigarette Lighter

Recommended Optional Tools:

- 1 ea. Center Punch
- 1 ea. Vehicle Hoist

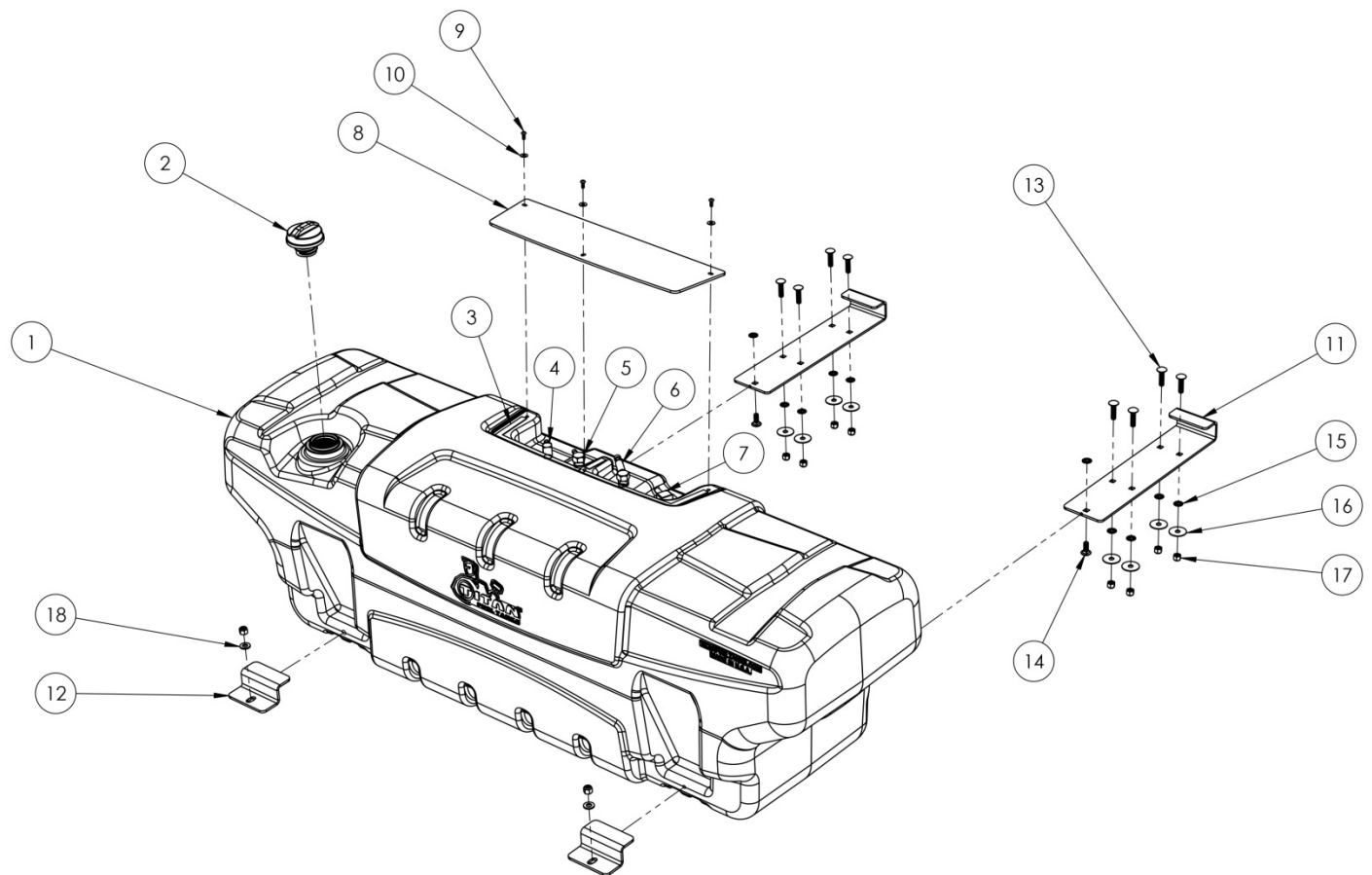

Exploded view showing the tank assembly of the Model 5410050.

Item Number	Part Description	Part Number	Quantity
1	Travel Trekker Tank Body	99 0000 0738	1
2	Black, Non-Locking Fuel Cap	99 0000 0534	1

3	Double Sided Tape	99 0000 0753	1
4	Withdraw Tube Assembly	99 0000 0745	1
5	Brass Roll Over Valve	99 0000 0137	1
6	Brass Roll Over Valve Assembly with Vent Cap	99 0174 0000	1
7	Electronic Level Sensor	99 0000 0750	1
8	Sending Unit Cover	99 0000 0741	1
9	10-24 X 1/2" Button Head Socket Cap Screw, Black Oxide Stainless Steel	99 0000 0748	3
10	#10 Screw Size Flat Washer, Black Oxide Stainless Steel	99 0000 0749	3
11	Mounting Bracket	99 0000 0739	2
12	Toe Clamp	99 0000 0740	2
13	3/8"-16 X 1-1/2" Carriage Bolt	99 0000 0587	8
14	3/8"-16 X 1" Carriage Bolt	99 0000 0751	2
15	3/8" Push Nut Retainer	02 0000 0162	10
16	3/8" Oversized Flat Washer, 1-1/2" OD	99 0000 0588	8
17	3/8"-16 Nylon Locknut	98 0000 0114	10
18	3/8" SAE Flat Washer	99 0000 0682	2
N/A	Grounding Wire	99 0173 0000	1
N/A	6-32 Machine Screw, 3/16" Length, Stainless Steel	99 0000 0756	1
N/A	Mounting Template	99 0000 0742	1
N/A	Installation Instructions	99 0000 0758	1
N/A	Electronic Controller	99 0130 0000	1
N/A	In-Line Pump with Hose Barbs	99 0000 0521	1
N/A	In-Line-Filter	99 0000 0405	1
N/A	Oval Head Drilling Screw, 1" Length	99 0000 0420	2
N/A	3/8" Fuel Hose, 6 Feet Length	99 0000 0759	1
N/A	5/16" Fuel Hose, 6 Feet Length	99 0000 0760	1
N/A	Vent Line Filler Neck Adapter	99 0000 0409	1
N/A	#8 Hose Clamp with 5/16" Band Width	99 0000 0422	2
N/A	#4 Hose Clamp with 5/16" Band Width	99 0000 0483	8
N/A	Push in Grommet	99 0000 0167	2
N/A	Adhesive Backed Velcro, 2 Inch Length	99 0000 0283	1
N/A	18 AWG Black Wire, 6 Feet	99 0000 0761	2
N/A	18 AWG Purple Wire, 20 Feet	99 0000 0201	1
N/A	18 AWG Blue Wire, 20 Feet	99 0000 0482	1
N/A	18 AWG Crimp Insulated Ring Terminal, 3/8" Stud	99 0000 0204	3
N/A	18 AWG Heat Shrink Butt Splice Terminal	99 0000 0203	6
N/A	22-18 Gauge Barrel Quick-Disconnect Terminal	99 0000 0489	1
N/A	ATM Fuse Tap	99 0000 0487	1
N/A	Wire Loom, 6 Feet	99 0000 0762	1

Important Note for Vehicles with Aluminum Bodies

Some manufacturers of the new aluminum body pickup trucks recommend that no steel components be attached directly to the body. While TITAN's in-bed products are made of military grade polymer, the mounting brackets are steel. TITAN offers a kit for the Travel Trekker™, which, when installed correctly insulates the steel components from the aluminum body. If your vehicle requires such an accommodation, ask your TITAN dealer for "9900001 Aluminum Body Insulator Kit for *Travel Trekker 50™*".

Tank Body Installation

I. Drill Mounting Holes

Step	Description
1	Following the diagram in Fig. 3, or using the included mounting template (99 0000 0742), measure and mark hole centers on mounting surface (See Fig. 3). <i>Before drilling, check under the bottom of the bed to make sure there are no cross members on the bed that will interfere with installation.</i> If there is a conflict, move the "footprint" of the tank slightly forward or back to clear the obstruction.
2	Drill eight mounting holes using a 3/8" drill bit (See Fig. 4). You will also need to drill three holes on the driver's side near the front of the bed. Two (3/4") will be required for the fuel hoses (supply and return lines) and one (1/2") for the wire loom to pass through (See Fig. 1). Install rubber grommets in the 3/4" holes for the two fuel lines (See Fig. 10).

NOTE: When assembling any of this product's threaded NPT connections, be sure to use a thread sealing tape or thread sealing compound. Be sure the tape or compound is compatible with motor fuels including biodiesel.



(Fig. 1) Holes for fuel lines and wire loom to pass. Grommets shown installed in fuel line openings.



(Fig. 2) Parts for Model 5410050

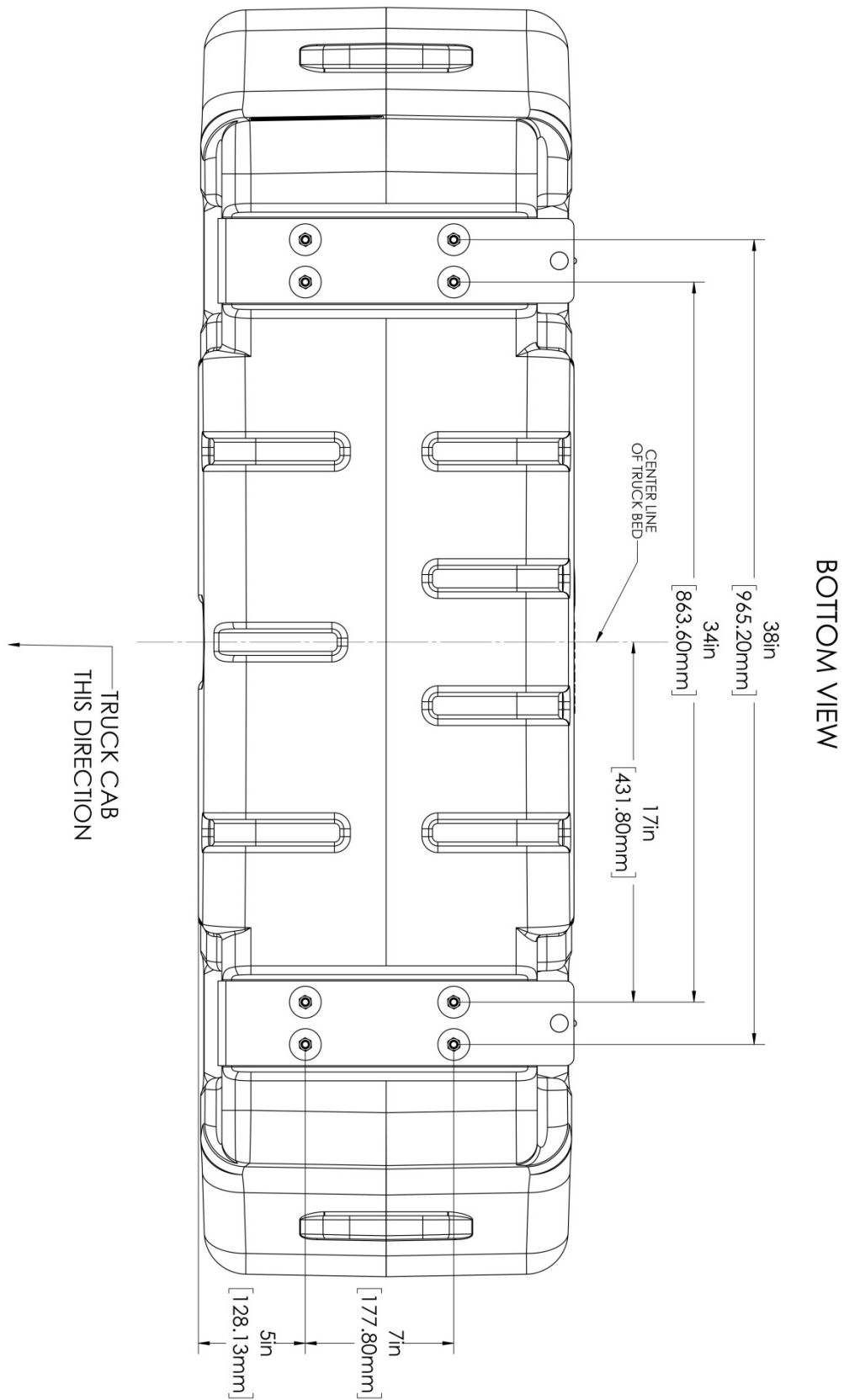

(Fig. 3) Mounting bracket bolt hole pattern for 50 Gallon, Travel Trekker, Model 5410050.



(Fig. 4) Template for drilling mounting holes taped down.

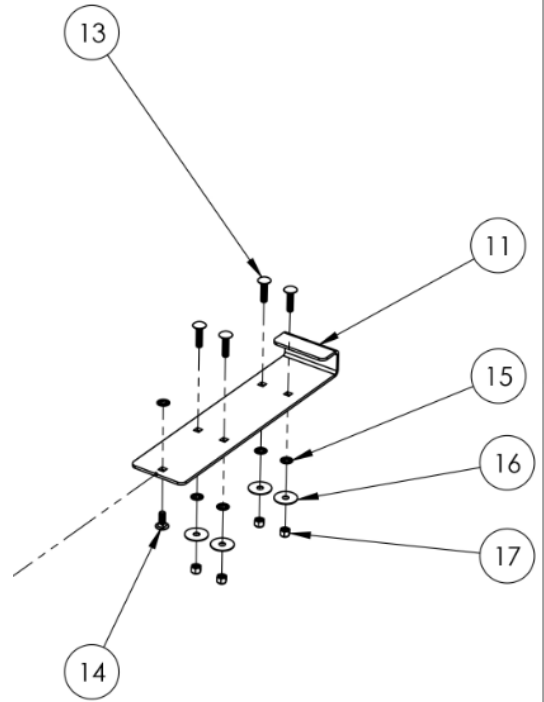

(Fig. 5) Assemble the Mounting Bracket's fasteners as shown here.



(Fig. 6) Use a deep socket to install Push Nut Retainer on 3/8" carriage bolts as shown.

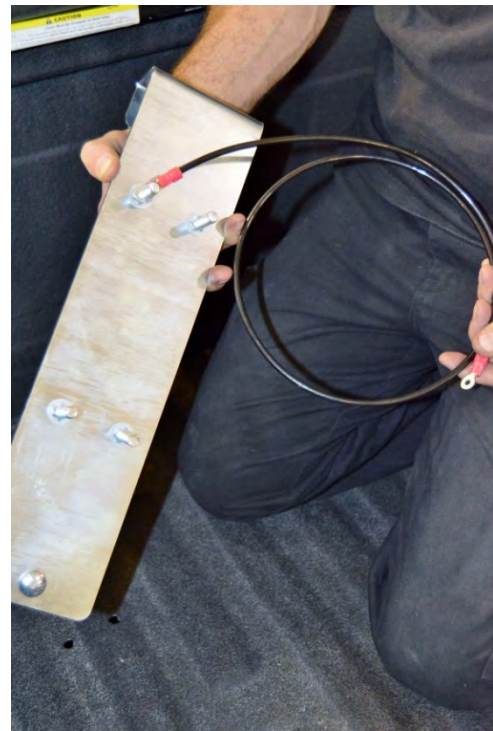

(Fig. 7) Install "99 0173 0000 Ground Wire Assembly" on front bolt in the "99 0000 0739 Mounting Bracket" which is to be installed on the driver's side of the vehicle.

II. Install Mounting Brackets

- 3 Assemble the two Mounting Brackets (99 0000 0739) with push nuts and carriage bolts as shown in Figs. 5 & 6.
- 4 Install the Grounding Wire Assembly on the front inside bolt of the driver's side (left hand) Mounting Bracket as shown in Figs. 7 & 8.
- 5 Install the two Mounting Brackets in the bed of the vehicle and install washers and nylon locknuts, finger tight, on the exposed bracket bolts underneath the bed.

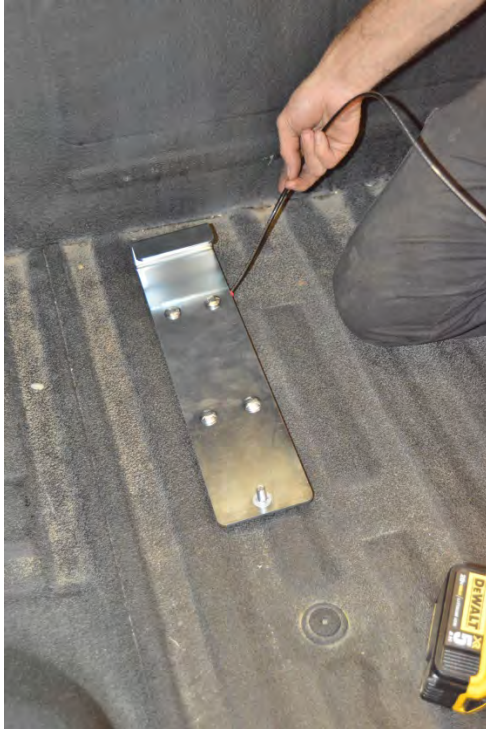

(Fig. 8) Driver's side Mounting Bracket installed. Note the ground wire attached to front inside bolt. The other end attaches to the Electronic Level Sensor.

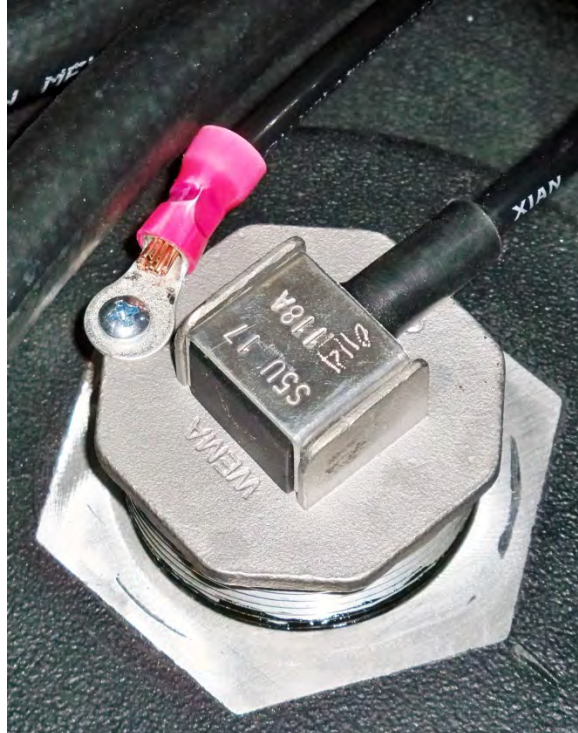

(Fig. 9) Showing grounding wire attached to the Electronic Level Sensor.

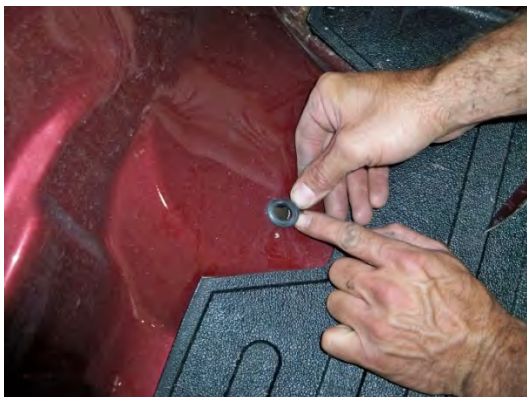

(Fig. 10) Install rubber grommet into fuel line hole(s).



(Fig. 11) Toe clamps installed on Mounting Brackets

III. Set Tank in Brackets

- 6 Place the tank body into the Mounting Brackets front clamps.
- 7 Install the two Toe Clamps (99 0000 0740) onto the brackets at the rear side of the tank. The Toe Clamps are slotted so as to be adjustable. Place them snugly against the tank and **tighten the Toe Clamp bolts to 25 lb. ft.** (See Fig. 11).
- 8 **Tighten locknuts underneath the bed to 25 lb. ft.**

IV. Installation of Fuel Transfer Tie-In to Vehicle's Fuel Tank

- 9 See parts photo (Fig. 2), "plumbing diagram below (Fig. 12), and wiring diagram (Fig. 15):

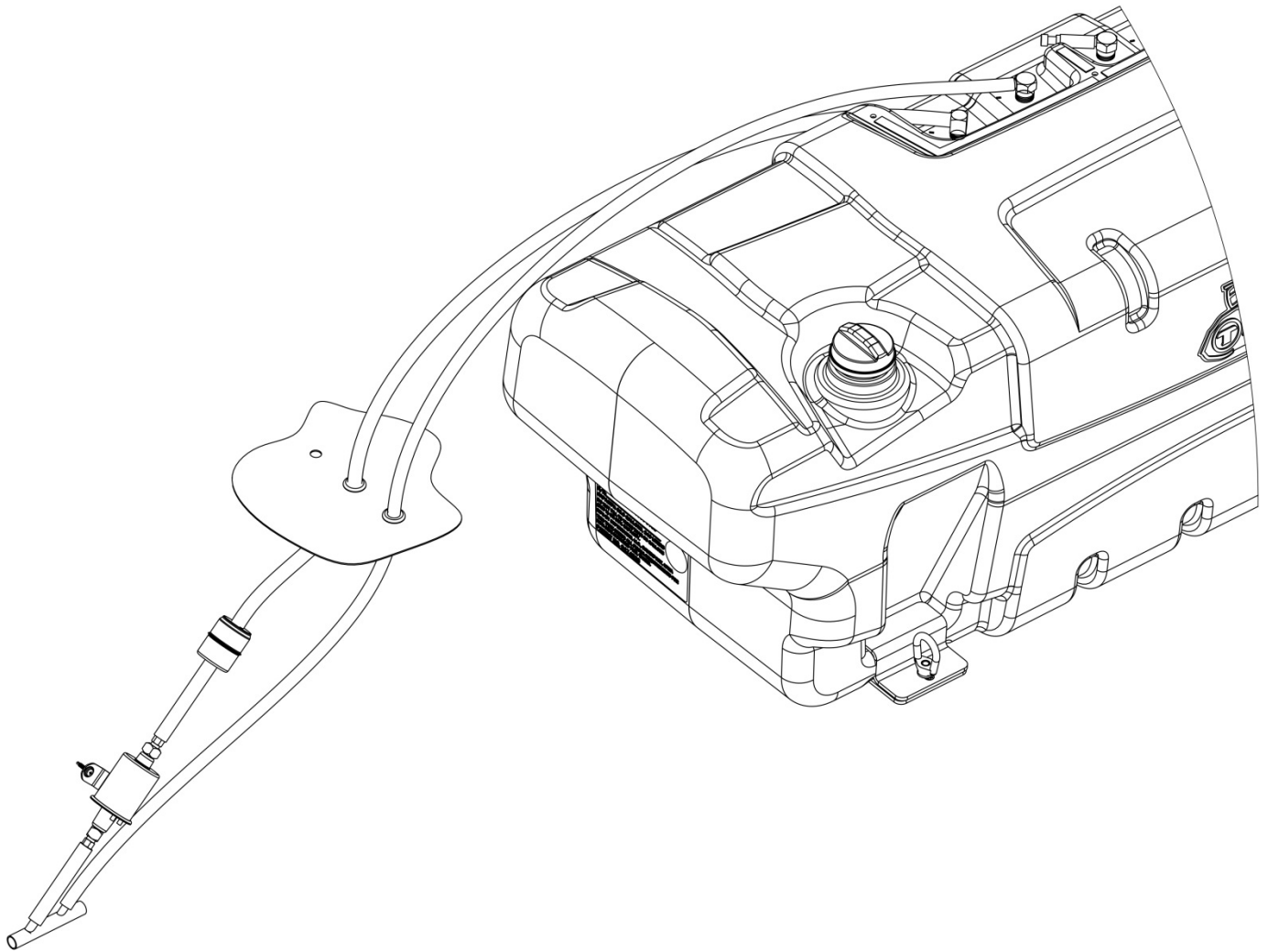

(Fig. 12) Plumbing Diagram for Model 5410050 Travel Trekker™, 50 gallon with TITAN™ Electronic Controller and pump system. Tank shown with optional eye nut tie downs.



(Fig. 13) Vent Line Filler Neck Adapter (99 0000 0409) with 5/8" barrel with 3/8" and 5/16" barbs.



(Fig. 14) Under the vehicle, showing the Vent Line Filler Adapter installed in the vehicle's vent line. Also shown, is the mounted pump, and fuel filter.

- 10 Install the "99 0000 0409 Vent Line Filler Neck Adapter" into the vehicle's vent line that runs from the vehicle's fuel tank to the filler neck. The main component (the barrel) of the adapter is 5/8", however, vehicle vent lines will vary from approximately 5/8" to 3/4". The Vent Line Adapter works for all of these when tightly clamped. It has two hose barbs, the larger, shown here (Fig. 13) at the top is 3/8" and the other is 5/16". When installed, the angle of the barbs on the adapter should point *toward* the tank (See Fig. 12). The 3/8" hose is the feed line from the pump and ultimately from the Withdraw Tube Assembly (99 0000 0745) and of course it attaches to the 3/8" hose barb on the Filler Neck Adapter. The 5/16" hose which attaches to the barb of the same size, is a return line which goes back to the Travel Trekker™ tank in the event the vehicle's tank over-fills. Proceed with installing the hoses and components as per the plumbing diagram in Fig. 12. Be sure to use hose clamps provided on all connections. Mount the pump as instructed in the next step.
- 11 In the 3/8" hose line, mount the pump under the pickup bed, using drilling screws and fasten in a convenient location, preferably in a somewhat sheltered place out of the path of water and ice. Be sure the inline filter is located in the line before the suction side of the fuel pump. Filter needs to be accessible for service (See Fig. 14).
- 12 Using the supplied ring terminal, ground black fuel pump wire to chassis member using supplied, extra wire, if needed. Attach red power wire on pump to blue 20 ft. wire provided, using supplied heat-shrink butt terminals. Cover with plastic loom. Run wire loom with blue and purple (from Electric Fuel Sensor) wire along frame rail to cab access. Refer to Fig. 15 , wiring diagram.

TITAN™ Electronic Controller Pump Wiring Diagram

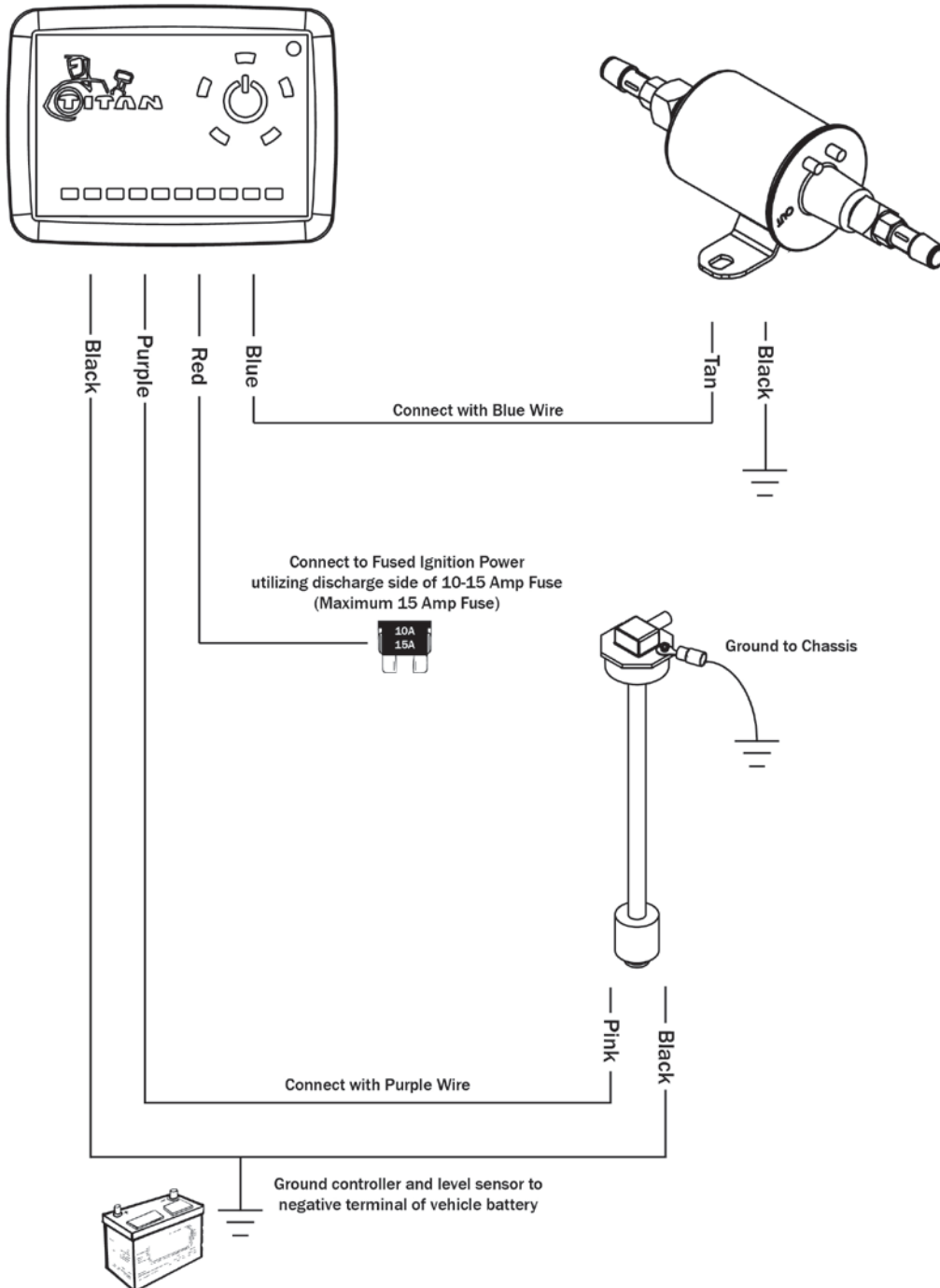

(Fig. 15) TITAN™ Electronic Controller, pump, and sensor wiring diagram.



(Fig. 16) Using the supplied fuse tap, connect power Input wire to output side of 10-15 Amp fuse (Max 15 Amp).

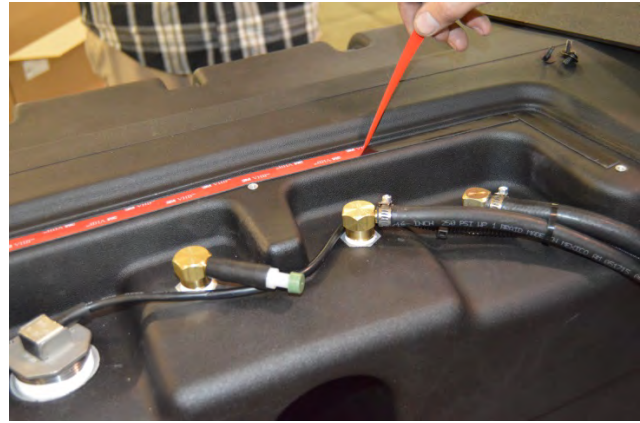

(Fig. 17) Showing completed plumbing and wiring on tank body. Tape backing is being removed in preparation for installation of the cover.

- 13 Complete the wiring as per wiring diagram (Fig. 15) and install fuse tap on output side of a 10-15 Amp fuse (Fig. 16) in the vehicle's fuse panel. Be sure to place the provided plastic wire loom on the system's wiring for extra protection. Please notice that the TITAN Controller only requires a power tap and the grounding point on the battery terminal; there is no invasion into the vehicle's wiring at any point.
- 14 Install the TITAN™ Controller in the vehicle's cab by drilling a hole at the chosen mounting point, threading the wire through, and using the Velcro tape to hold the controller firmly (Fig. 18).



(Fig. 18) TITAN™ Electronic Controller mounted on dash.

VI. Fill and Final Check

- 15 Make a complete careful check of all components to be sure that all bolts, clamps, caps, accessories and misc. are tight and secure.
- 16 **IMPORTANT: Fill tank completely with fuel and inspect all components carefully to be sure that there are no leaks or other problems. Check the operation of any valves, pumps or control systems.**

17 Study Fig. 19 below for instructions on operating the TITAN™ Controller.

TITAN™ Electronic Controller

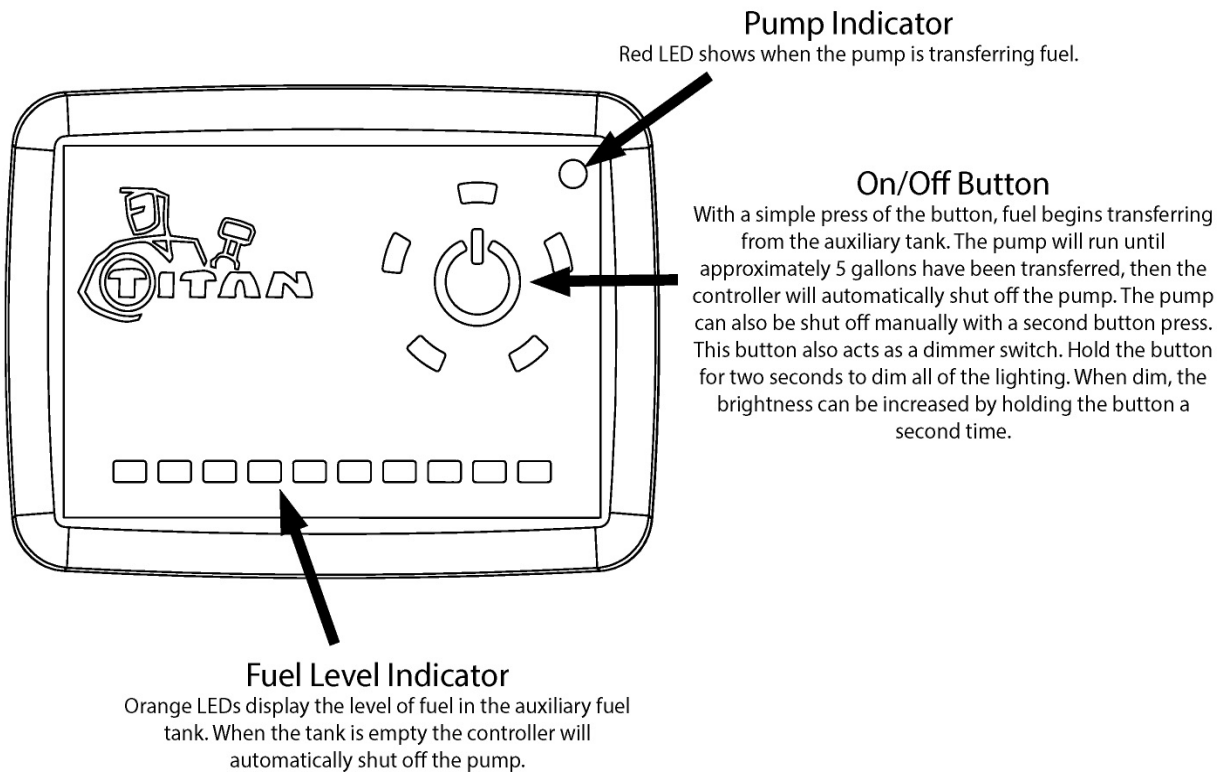

(Fig. 19) Operating instructions for TITAN™ Electronic Fuel Controller.

Troubleshooting Guide

Consistently, the biggest problem we see causing system malfunctions is a poor or uncertain ground or a bad connection. A poor ground will cause the electronic controller, pump, and other components not to function or to perform intermittently. Below you will find a troubleshooting guide to help if you are experiencing system problems.

Controller does not light: 1) Check for power on the red wire to the controller. If you have no power, check the connections and the fuse providing power from the vehicle's electrical system. 2) Check the connections on the ground which is the black wire from the controller. Make sure the level sensor and the electronic controller are grounded to a common grounding point on the negative terminal of the battery (see Fig. 15)

Controller lights, but the level indicator bars do not: 1) Make sure there is sufficient fuel in the tank. The indicator bars and the pump will not function if the level sensor reads "empty". 2) Check connections on the level sensor circuit. This is a purple wire leading from the controller which connects to the pink wire on the level sensor. The level sensor's black wire and the controller's black ground wire must be securely grounded at the same, common point to the negative battery terminal (see Fig. 15).

Pump runs slow: Check the ground (black wire) on the pump itself.

Pump makes noise, but doesn't transfer fuel: Inspect feed line (3/8 line from tank to filter/pump assembly, then also pump to primary tank) for kinks or a plugged fuel filter.

Pump does not run: Check the pump and controller grounds. Also, assure there is 12 volts to the pump when activated (on blue wire from the controller).

Controller flashes and does not light the red "transfer" light in the upper right corner:

This is a sign of excess system resistance.

Step 1) Check the grounds on both the controller (Fig. 15) and the pump.

Step 2) Inspect the fuel feed line that goes to the pump to assure it is not kinked that the fuel filter is not clogged.

Step 3) Inspect the blue wire from the controller to the pump and the wiring to the level sensor (the purple wire from the controller) for damage such as being pinched, a fault in the insulation, etc. Check the ground on the level sensor (black wire) to be sure it is adequate.

The level sensor is basically a resistor with a maximum of 240 ohm when the tank is empty, and 33 ohm when the tank is full. If the level sensor is outside of that specification (caused by inadequate ground or a damaged or faulty wire) it will put the entire system out of specification.

Once again, a good ground is mandatory for each component in this system. A poor ground will add unnecessary resistance and cause feedback from one component to another. Added resistance causes the controller to reset as a failsafe.

5.25.17

Important Note for Chrysler RAM Vehicles

Some 2013 and newer Chrysler RAM products feature a vent line breather which is usually located in the fender well just under the vehicle's fill spout assembly (See Fig. 20). On some of these vehicles, especially the EcoDiesel, this breather is susceptible to leakage which can be exacerbated by filling from an auxiliary system. If this is a problem for your vehicle, it can be addressed in one of two ways: **1)** Since the vehicle's OEM underbody tank is now also vented through the Travel Trekker™, the vent line can be trimmed and plugged as discussed in Fig. 20. or **2)** Trim the vent line where shown in Fig. 20 and add a short piece of hose and a one way check valve as a breather as shown in Fig. 21. Ask your TITAN dealer for **"9900002 One-Way Breather Kit for Chrysler Vehicles"**.

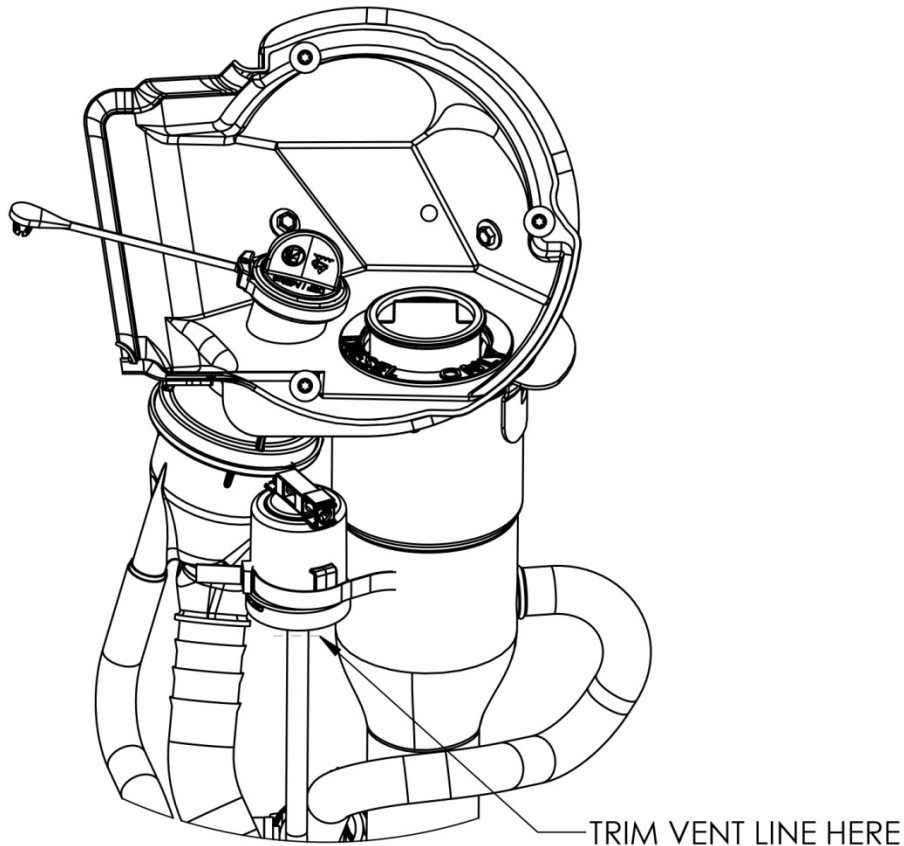

(Fig. 20) Fill spout assembly on some Chrysler RAM products. The vent line breather is shown just above the point of the arrow. Since the vehicle's underbody tank is now also vented through the Travel Trekker™, the vent line can be cut where indicated on the illustration. Then, slip on a short piece of 3/8" hose over the vent line and plug with a plastic plug, or small cap screw, etc. Be sure to use hose clamps to insure a leak-proof seal.

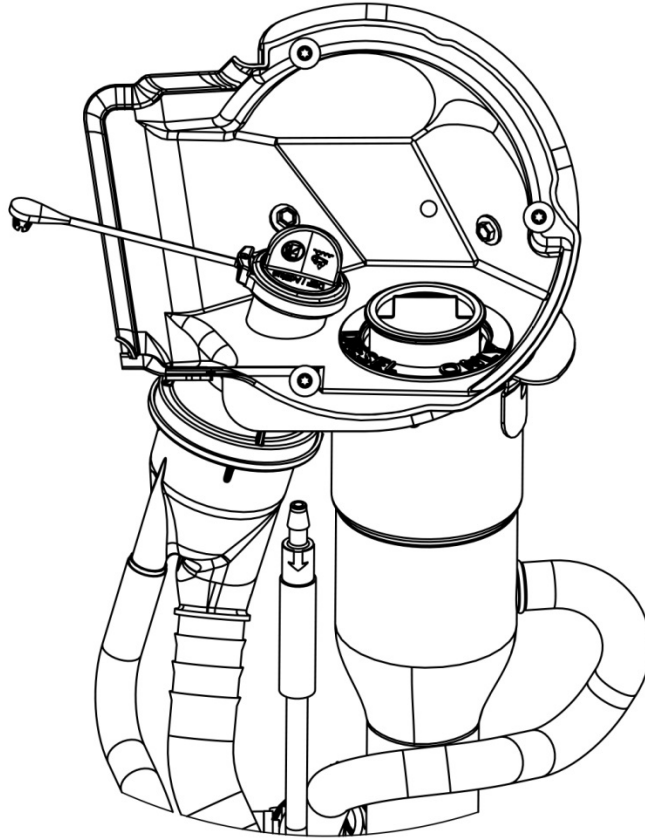

(Fig. 21) Chrysler RAM fill spout assembly showing the factory vent line breather replaced with a short piece of 3/8" hose and a one-way check valve as a breather.