

URMDR

INSTALLATION INSTRUCTIONS

- Raise vehicle allowing the axle to hang freely.
- Remove existing bump stop assembly.
- Assemble Aeon rubber spring and bracket as shown in the adjacent diagram.
- Mount Timbren assembly to axle using Timbren supplied fasteners as shown in the adjacent diagram.
- Lower vehicle.

NOTES:

Check that brake line or brake cable locations do not interfere with Aeon spring bracket.

Do not exceed vehicle manufacturer's recommended axle weight rating. Check for AEON® interference with vehicle components - Under load AEON® will "expand" in diameter.

Ref. = Reference
Part = Part #.
Qty. = Quantity

Ref	Part	Qty
1	F11064-250	4
2	A00200-65Q30	2
3	F31005-250	4
4	F40052-020	8
5	K10411-003	1L
6	K10419-003	1
7	F11400-250	2
8	K10409-003	1
9	K51279-003	1
10	F11119-250	2

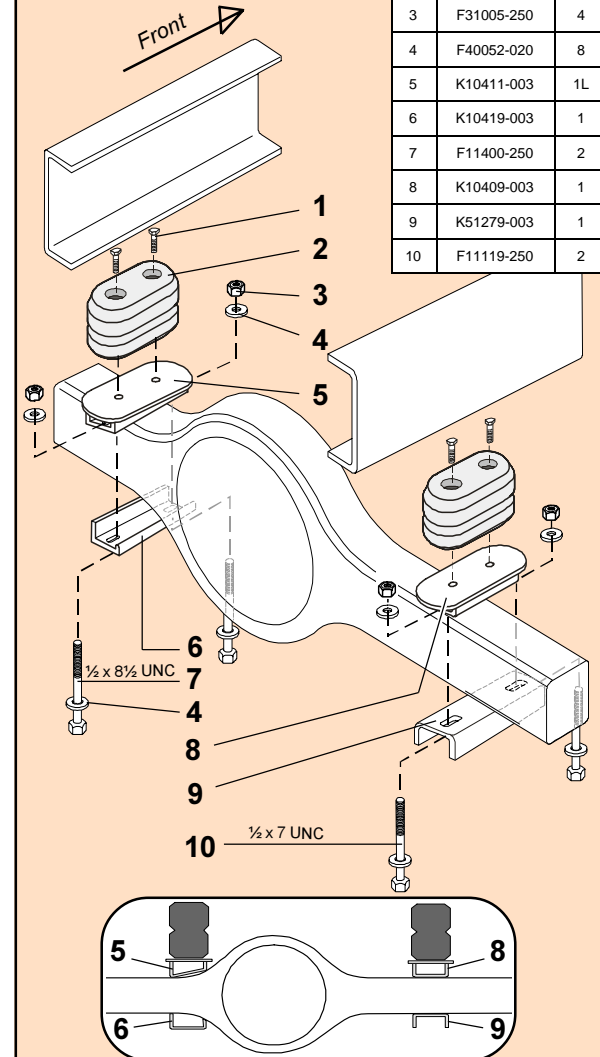

URMDR

PART NUMBER	DESCRIPTION	QTY	LOCATION
F31005-250	NYLOCK LOCKNUT 1/2 UNC GR 5 Z	4	G1B
F40052-020	WASHER FLAT USS 1/2 x 1-3/8 GR 2 Z	8	G1D
F11119-250	HCS 1/2 x 7 UNC GR 5 Z	2	G3A
F11400-250	HCS 1/2 x 8-1/2 UNC GR 5 Z	2	G3A
F11064-250	HCS 3/8 x 1-3/4 UNC GR 5 Z	4	G3D
A00200-65Q30	Hollow Rubber Spring	2	C17B
K10411LH-003	URMDF / URMDR WELDMENT RH PAINTED	1	D5D
K10409-003	URMDE/ URMDF/ URMDR WELD. PAINTED	1	D5D
K10419-003	URMDF / URMDR WELDMENT PAINTED	1	D5E
K51279-003	CHANNEL 1-1/2 x 3 x 7 x 3/8 PAINTED	1	D5E
B90223	10-3/4 x 9-1/2 x 7 DW Carton	1	A1A
B10100	NEWSPRINT 18" ROLL	1	
B00029-010	BARCODE LABEL FOR KIT	1	

ASSEMBLY NOTES:

APPLY 'LEFT' LABELS TO K10411LH & K10419 BRACKETS.

NOTE: PACKAGE F11119-250 & F11400-250 BOLTS LOOSE IN BOX.

Clearance Instructions:

Rear SES Kits for Pick-Ups and Vans should have a 1/2" to 1-1/2" gap between the rubber spring and contact point when empty.

A partial load, or vehicle accessories will reduce or eliminate the gap.

Front SES kits are usually in full contact.

Medium and Heavy-Duty Trucks, Trailers and Motorhomes will be in constant contact, and have no gap.