

UR350

Rear suspension package

INSTALLATION INSTRUCTIONS

- a) LEAF SPRING: With vehicle unloaded measure 5" from the Timbren frame bracket to axle pad.
- b) AIR SUSPENSION: With vehicle unloaded & full air pressure measure 5" from the Timbren frame bracket to axle pad.
- c) When positioning frame bracket ensure that the Aeon spring rests over center of axle pad.
- d) Drill holes for frame bracket providing for at least four 3/8" Gr.5 bolts through the bracket & frame. (Bolt frame bracket to frame using existing holes where possible)
- e) Assemble Aeon spring to bracket as shown in adjacent diagram.
- f) Lower vehicle.

SAFETY CAUTIONS

Always refer to and follow the vehicle manufacturer's guidelines when welding or drilling during installation of this kit.

Do not exceed vehicle manufacturer's recommended axle weight rating. Check for AEON® interference with vehicle components - Under load AEON® will "expand" in diameter.

Ref. = Reference
Part = Part #.
Qty. = Quantity

Ref	Part	Qty
1	F31003-150	8
2	F11062-150	8
3	F31005-150	2
4	F40052-020	2
5	K10021-003	2
6	A00535-65E60	2
7	F11104-150	2

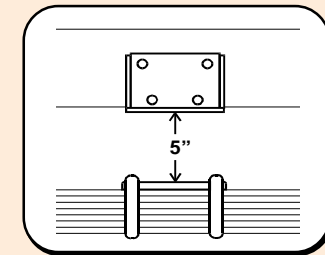
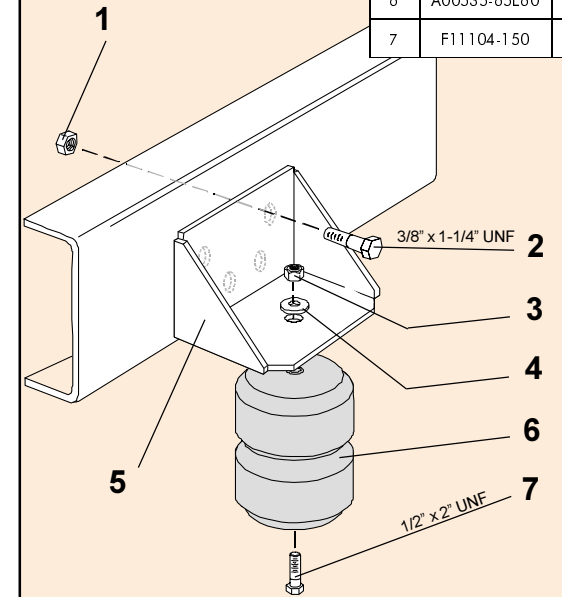

UR350

PART NUMBER	DESCRIPTION	QTY	LOCATION
F31005-150	NYLOCK LOCKNUT 1/2 UNF GR 5 Z	2	G1D
F40052-020	WASHER FLAT USS 1/2 x 1-3/8 GR 2 Z	2	G1D
F11104-150	HCS 1/2 x 2 UNF GR 5 Z	2	G1D
F31003-150	NYLOCK LOCKNUT 3/8 UNF GR 5 Z	8	G1C
F11062-150	HCS 3/8 x 1-1/4 UNF GR 5 Z	8	G1C
A00535-65E60	Hollow Rubber Spring	2	C7B
K10021-003	UR350 WELD'T (PAINTED)	2	D21D
B90200-CR	SMALL REAR BOX - 9.5 x 7 x 5.5	1	A--E
B10000	8" x 12" BUBBLE FOR KITS	1	
B00029-010	BARCODE LABEL FOR KIT	1	

Clearance Instructions:

Rear SES Kits for Pick-Ups and Vans should have a 1/2" to 1-1/2" gap between the rubber spring and contact point when empty.

A partial load, or vehicle accessories will reduce or eliminate the gap.

Front SES kits are usually in full contact.

Medium and Heavy-Duty Trucks, Trailers and Motorhomes will be in constant contact, and have no gap.