

# TRA1032

Suspension package for trailer

## INSTALLATION INSTRUCTIONS

- Create frame bracket assembly by inserting bolt #1 into countersunk hole of Timbren top plate and tack weld into place.
- Position frame bracket assembly above center line of leaf spring & weld to chassis frame.
- After weldment has cooled, mount Aeon rubber spring onto frame bracket assembly using Timbren fasteners supplied.
- Configure items #6, #7, #8, welding them together to obtain a 3" space (unloaded) between lower plate (item #6) and upper frame bracket. (Use diagrams on page 2 as a guide)
- Weld lower disc assembly to U-bolt pad.

### SAFETY CAUTIONS

Always refer to and follow the vehicle manufacturer's guidelines when welding or drilling during installation of this kit.

*Do not exceed vehicle manufacturer's recommended axle weight rating. Check for AEON® interference with vehicle components - Under load AEON® will "expand" in diameter.*

Ref. = Reference  
Part = Part #.  
Qty. = Quantity

Ref	Part	Qty
1	F12104-253	2
2	K54013-005	2
3	A0103B-65E00	2
4	F40053-020	2
5	F31005-250	2
6	K52195-005	2
7	K51129-005	2
8	K52154-005	4

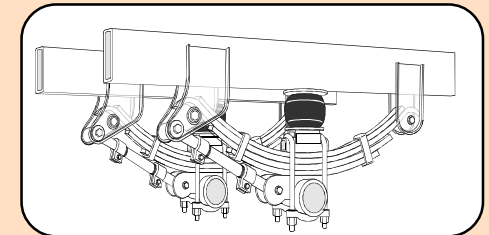
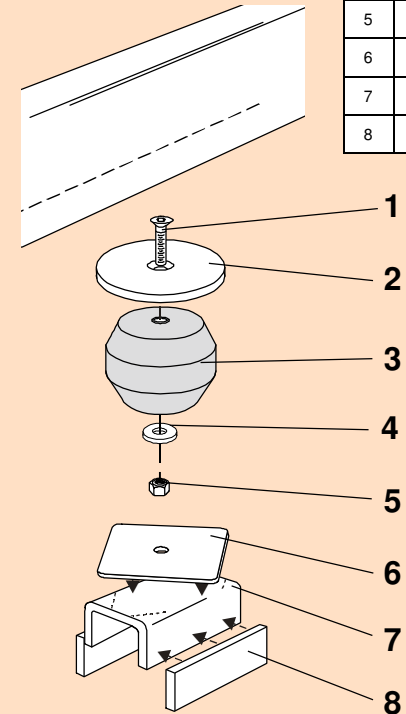

# TRA1032

## Suspension package for trailer

### Note:

Chassis frames and suspension mounting can be mixed and matched.

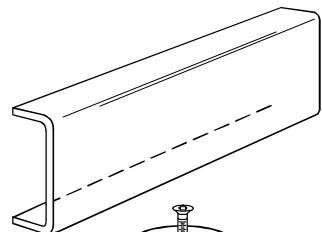
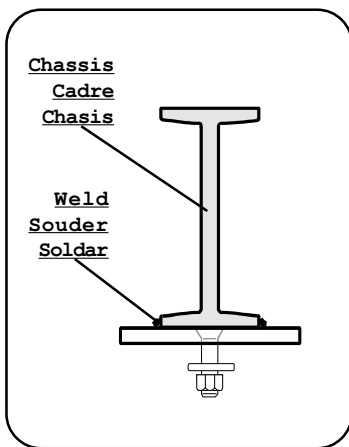

**A**

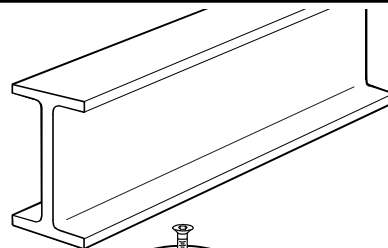
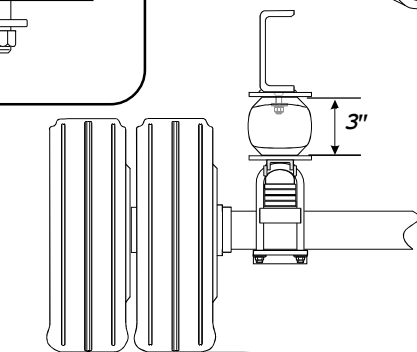
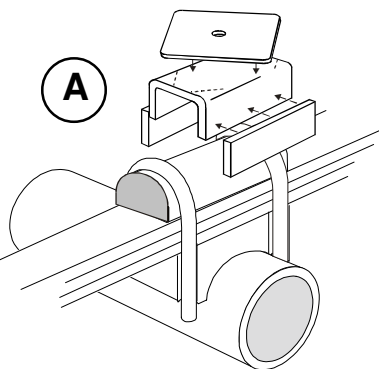

**B**

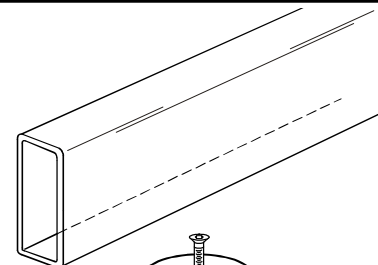
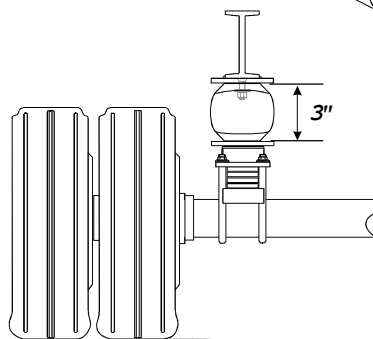
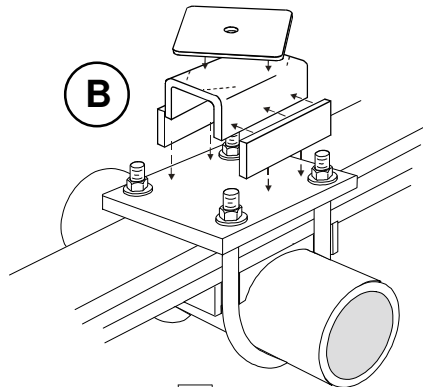

**C**

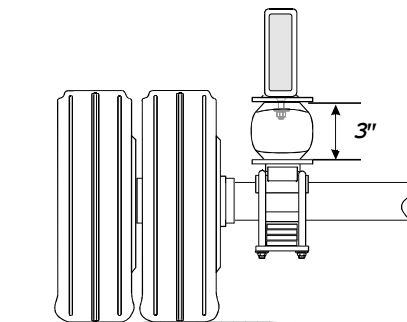
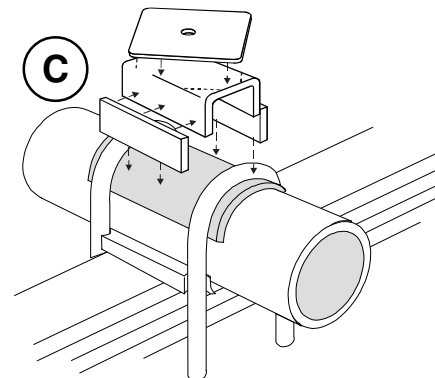



Ride Quality Control

# TIMBREN SES

Suspension Enhancement Systems

## Limited Lifetime Warranty

*TIMBREN SES kits are warranted against defects in material and workmanship, under normal use and service, for the life of the vehicle on which the kit was originally installed. The warranty is not transferable and proof of purchase is required. The warranty is limited to the replacement of the failed part. TIMBREN will not be responsible for any labour or freight charges involved in the replacement of any product. TIMBREN shall be entitled to make its own inspection to determine the validity of the warranty claim. TIMBREN shall not be liable nor warrant the product in the event of alteration, misuse, overload, negligence or damage caused by others.*

### Clearance Instructions

Typical Light Duty & Medium Duty Installation

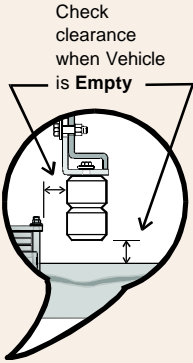

Check clearance when Vehicle is Empty

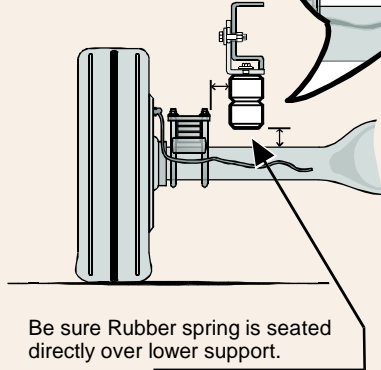

Be sure Rubber spring is seated directly over lower support.

Typical Heavy Duty Installation

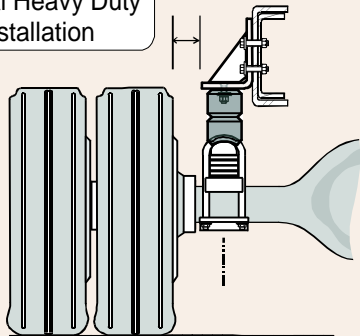

#### For Light Duty Pickups & Vans

Rear SES kits should have approximately 1" gap between rubber spring and axle for 1/2 and 3/4 tons, and for one ton the gap should be about 1/2" when the vehicle is completely unloaded. A cap or fifth wheel plate will reduce or eliminate this gap.

Front SES kits are usually in contact with the front suspension at all times.

#### For Medium Duty & Heavy Duty Trucks, Trailers, Motor Homes, and more

Medium & Heavy Duty vehicles often have pre-load as outlined in the instruction sheet. (For specific Medium Duty applications with a constant load on the suspension like Rvs, Utility Vans or Cube Vans, the Timbren SES kits are pre-loaded.)

### Check clearances when vehicle is empty...

### Consider Your Needs..!

Knowing the use of the vehicle will help you to select the right SES kit. For example a one ton truck can be configured as a pick-up, service vehicle or tow truck. Standard capacity or severe service applications are available for many applications.

Knowing that the suspension has been modified or is old and sagging should indicate the need to adjust the ride height to obtain the correct clearance.

This can be done by altering the SES kit (changing rubber spring or bracket) or re-arching the leaf springs to renew the optimum OEM ride height.

Timbren Industries Inc. ©