

# MST001

Front suspension package

## INSTALLATION INSTRUCTIONS

- a) Choose the best location:
  - 1) Center of U-bolt pad
  - 2) Immediate Rear of U-bolt pad
- b) Assemble frame bracket by welding items #1 & #2 together keeping in mind the following:
  - 1) Plate #2 should be positioned under bracket #1 to allow the Aeon spring to rest directly over the leaf spring
  - 2) Bracket #1 will be bolted to the frame using existing holes where possible to ensure that the distance from the bottom of plate #2 to the top of leaf spring is 6-3/4 inches. Adjust accordingly with the use of spacers. (Diagram A)
- c) With vehicle unloaded, mount bracket to frame using at least three 1/2" Gr.8 bolts.
- d) Raise vehicle to install remainder of Timbren assembly.
- e) If choosing to install at location diagram 1, weld disc/plate #7 to axle pad directly below Timbren assembly.
- f) Lower vehicle.

### NOTES:

Countersunk bolt #3 will need to be tack welded into place prior to welding items #1 & #2.

If necessary, drill to enlarge holes in frame to 9/16" diameter.

### SAFETY CAUTIONS

Always refer to and follow the vehicle manufacturer's guidelines when welding or drilling during installation of this kit.

*Do not exceed vehicle manufacturer's recommended axle weight rating. Check for AEON® interference with vehicle components - Under load AEON® will "expand" in diameter.*

Ref. = Reference  
Part = Part #.  
Qty. = Quantity

Ref	Part	Qty
1	K51116-005	2
2	K52005-005	2
3	F12104-253	2
4	A16050	2
5	A00740-75E60	2
6	F31005-250	2
7	A1610B-005	2

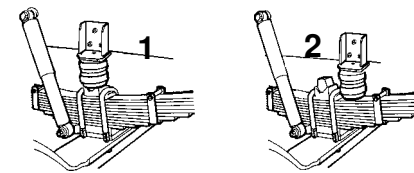
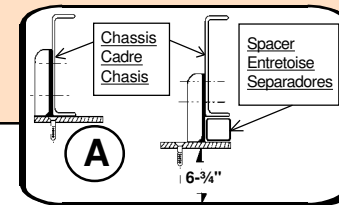
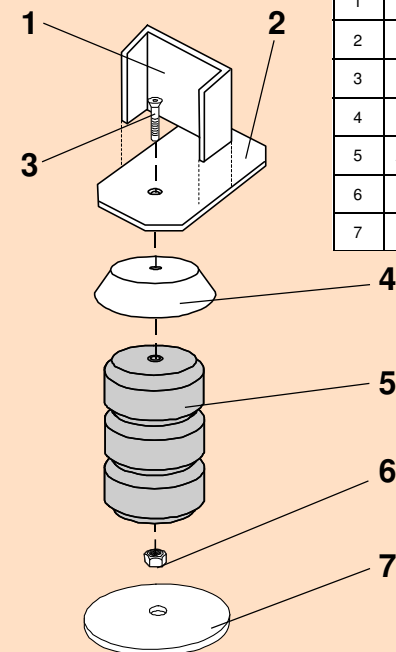

## MST001

PART NUMBER	DESCRIPTION	QTY	LOCATION
<b>F31005-250</b>	NYLOCK LOCKNUT 1/2 UNC GR 5 Z	2	<b>G1B</b>
<b>F12104-253</b>	FHSCS 1/2 x 2 UNC GR 5 B	2	<b>J2C</b>
<b>A00740-75E60</b>	Hollow Rubber Spring	2	<b>C14C</b>
<b>K51116-005</b>	FORMED PLATE 1/4 x 7 x 7-9/16	2	<b>D4D</b>
<b>K52005-005</b>	3/8 X 4-1/2 X 7	2	<b>D4D</b>
<b>A1610B-005</b>	WASHER 4-1/2 OD x 17/32 ID x 1/4 THK PTD.	2	<b>D20A</b>
<b>A16050</b>	STEEL CUP 6-1/8 od x 17/32 id x 2-11/16 deep	2	<b>D21A</b>
<b>B90223</b>	10-3/4 x 9-1/2 x 7 DW Carton	1	<b>A1A</b>
<b>B10100</b>	NEWSPRINT 18" ROLL	1	
<b>B00029-010</b>	BARCODE LABEL FOR KIT	1	

Issued: 10/25/2011

### Clearance Instructions:

Rear SES Kits for Pick-Ups and Vans should have a 1/2" to 1-1/2" gap between the rubber spring and contact point when empty.

A partial load, or vehicle accessories will reduce or eliminate the gap.

Front SES kits are usually in full contact.

Medium and Heavy-Duty Trucks, Trailers and Motorhomes will be in constant contact, and have no gap.