

MRMPV

MAZDA

Rear suspension package

INSTALLATION INSTRUCTIONS

- a) Raise vehicle allowing the axle to hang freely.
- b) Remove rear coil springs as per manufacturers instructions. (1991-1999)
- c) Remove existing bump stop.
- d) Assemble Aeon rubber spring and bracket as shown in the adjacent diagram.
- e) Mount Timbren assembly using existing holes & Timbren supplied fasteners.
- f) Re-install coil springs as per manufacturers instructions. (1991-1999)
- g) Lower vehicle.

SAFETY CAUTIONS

Professional installation required.

Do not exceed vehicle manufacturer's recommended axle weight rating. Check for AEON® interference with vehicle components - Under load AEON® will "expand" in diameter.

Ref. = Reference
Part = Part #.
Qty. = Quantity

Ref	Part	Qty
1	K10130-003	2
2	A00530-65P30	2
3	F11548-450	2
4	F11542-450	2

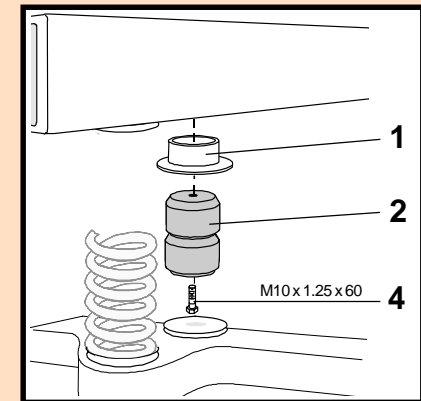
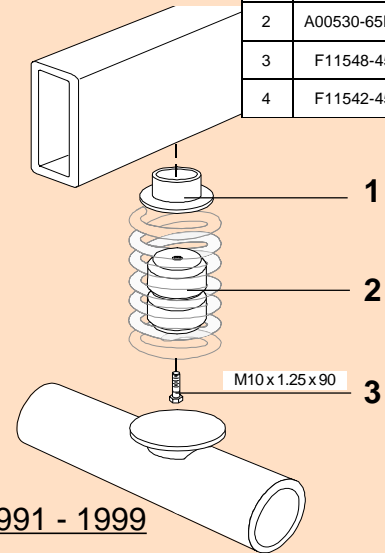

MRMPV

PART NUMBER	DESCRIPTION	QTY	LOCATION
F11542-450	HCS M10 x 60 x 1.25 8.8 Z	2	I1E
F11548-450	HCS M10 x 90 x 1.25 8.8 Z	2	I2E
A00530-65P30	Hollow Rubber Spring	2	C6A
K10130-003	GMRYT4 WELD'T (PAINTED)	2	D21D
B90200-CR	SMALL REAR BOX - 9.5 x 7 x 5.5	1	A--E
B10000	8" x 12" BUBBLE FOR KITS	1	
B00029-010	BARCODE LABEL FOR KIT	1	

Issued: 2/20/2008

Clearance Instructions:

Rear SES Kits for Pick-Ups and Vans should have a 1/2" to 1-1/2" gap between the rubber spring and contact point when empty.

A partial load, or vehicle accessories will reduce or eliminate the gap.

Front SES kits are usually in full contact.

Medium and Heavy-Duty Trucks, Trailers and Motorhomes will be in constant contact, and have no gap.