

HRTT01HD

HENDRICKSON

Rear suspension package

INSTALLATION INSTRUCTIONS

- With vehicle unloaded, measure 6-3/4" from top of U-bolt pad (or Timbren bottom plate) to bottom of Timbren frame bracket (see Diagram A)
- Drill holes for Timbren bracket providing for at least four 1/2" Gr.8 bolts through the bracket & frame.
- Assemble Aeon rubber spring and Timbren frame bracket.
- Remove rear rebound bolt. Using a pillow jack between leaf spring & frame, jack the leaf spring away from the spring hanger (about 3"). Be sure to block the two apart (see diagram B)
- Bolt the Timbren assembly to the frame making sure that the bottom plate is in place. Let the frame come down to rest on bottom plate.
- Reinstall the rebound bolt.
- See page 2 for installation instructions of bottom plate #6.

SAFETY CAUTIONS

Ensure sufficient clearance between frame bracket & tire.

Always refer to and follow the vehicle manufacturer's guidelines when welding or drilling during installation of this kit.

Do not exceed vehicle manufacturer's recommended axle weight rating. Check for AEON® interference with vehicle components - Under load AEON® will "expand" in diameter.

Ref. = Reference
Part = Part #.
Qty. = Quantity

Ref	Part	Qty
1	K10001-005	2
2	F31005-150	4
3	F40053-020	8
4	A00260-75D60	2
5	F11106-150	4
6	K51079-005	2
7	K53016-005	8
8	K10017-003	2
9	F11104-150	4

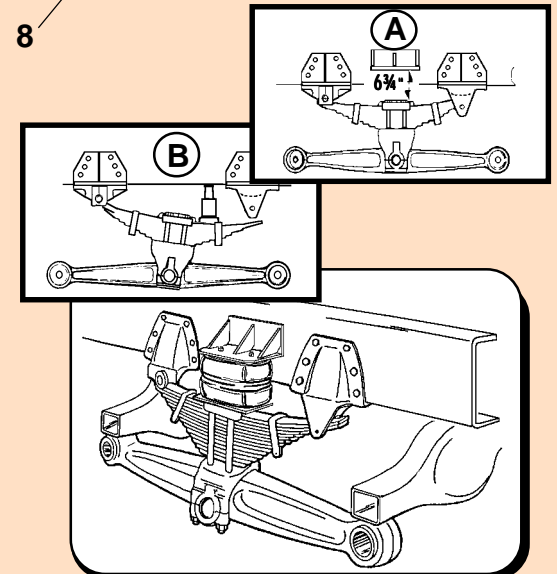
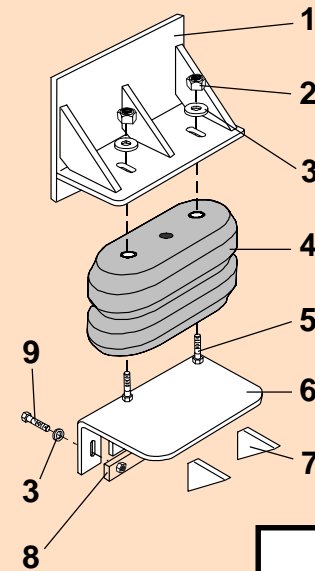

HRTT01HD



HRTT01HD

PART NUMBER	DESCRIPTION	QTY	LOCATION
F31005-150	NYLOCK LOCKNUT 1/2 UNF GR 5 Z	4	G1D
F40053-020	WASHER FLAT 1/2 x 1-1/2 GR 2 Z	8	G4A
F11104-150	HCS 1/2 x 2 UNF GR 5 Z	4	G1D
F11106-150	HCS 1/2 x 2-1/2 UNF GR 5 Z	4	G1D
A00260-75D60	Hollow Rubber Spring	2	C17E
K10001-005	HRTT01 / PTA001 WELDMENT PAINTED	2	D2A
K10017-003	HRTT01 WELDMENT PAINTED	2	D6B
K51079-005	FORMED PLATE 3/8 x 12 x 14-3/4 PAINTED	2	D6B
K53016-005	GUSSET 3/8 x 1-1/2 x 3 PAINTED	8	D6B
B90213	#200 DOUBLE WALL BOX - 13 x 13 x 7"	2	A4A
B10100	NEWSPRINT 18" ROLL	1	
B00029-010	BARCODE LABEL FOR KIT	2	
	1 of 2 & 2 of 2 LABELS	1 ea.	

ASSEMBLY NOTES:

ALL COMPONENTS ARE DIVIDED IN HALF AND PACKAGED INTO TWO IDENTICAL PACKAGES.

APPLY "1 of 2" and "2 of 2" LABELS TO CARTONS.

Clearance Instructions:

Rear SES Kits for Pick-Ups and Vans should have a 1/2" to 1-1/2" gap between the rubber spring and contact point when empty.

A partial load, or vehicle accessories will reduce or eliminate the gap.

Front SES kits are usually in full contact.

Medium and Heavy-Duty Trucks, Trailers and Motorhomes will be in constant contact, and have no gap.