

GMRCCA

Rear suspension package

INSTALLATION INSTRUCTIONS

- Partially raise vehicle not allowing the axle to hang freely.
- Loosen axle U-bolts and remove existing bump stop.
- Assemble Aeon rubber spring and bracket as shown in the adjacent diagram.
- Mount Timbren assembly to axle & retighten U-bolts as per manufacturers instructions.
- Lower vehicle.

Do not exceed vehicle manufacturer's recommended axle weight rating. Check for AEON® interference with vehicle components - Under load AEON® will "expand" in diameter.

Ref. = Reference
Part = Part #.
Qty. = Quantity

Ref	Part	Qty
1	F31003-250	2
2	A00535-55Q30	2
3	K10442-003	2
4	F12063-653	2

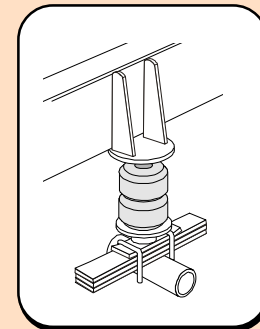
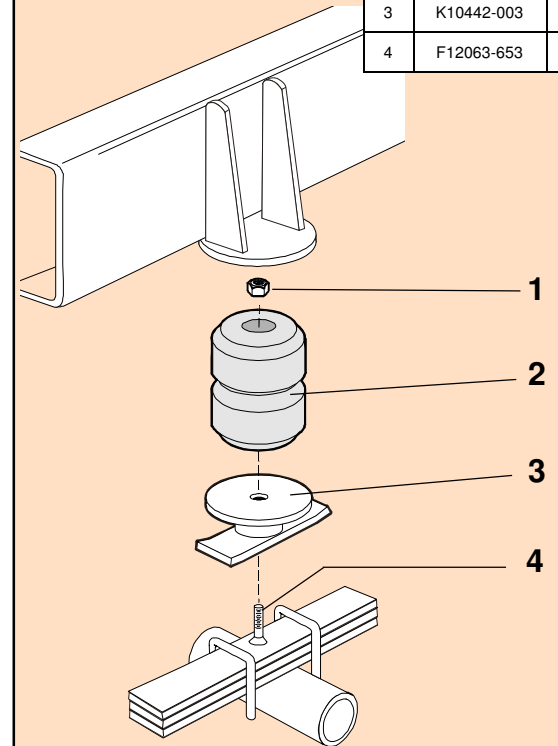

GMRCCA

PART NUMBER	DESCRIPTION	QTY	LOCATION
F31003-250	NYLOCK LOCKNUT 3/8 UNC GR 5 Z	2	G1B
F12063-653	FHSCS 3/8 x 1-1/2 F/T UNC GR 5 B	2	J2E

A00535-55Q30	Hollow Rubber Spring	2	C7A
---------------------	----------------------	----------	------------

K10442-003	GMRCCA / TORTUN4L WELDMENT PAINTED	2	D21F
-------------------	------------------------------------	----------	-------------

B90200-CF	SMALL FRONT BOX - 9.5 x 7 x 5.5	1	A--E
B10000	8" x 12" BUBBLE FOR KITS	1	
B00029-010	BARCODE LABEL FOR KIT	1	

Clearance Instructions:

Rear SES Kits for Pick-Ups and Vans should have a 1/2" to 1-1/2" gap between the rubber spring and contact point when empty.

A partial load, or vehicle accessories will reduce or eliminate the gap.

Front SES kits are usually in full contact.

Medium and Heavy-Duty Trucks, Trailers and Motorhomes will be in constant contact, and have no gap.