

FR250SDE

FORD

Rear suspension package

INSTALLATION INSTRUCTIONS

- Raise vehicle allowing the axle to hang freely.
- Remove existing bump stop & bushing. (See diagram A & B)
- Assemble Aeon rubber spring and bracket as shown in the adjacent diagram.
- Mount Timbren assembly using existing holes & Timbren supplied fasteners.
- Lower vehicle.

NOTES

Use rubber washer #5 and bolt #7 to achieve desired ride height.

Check that brake line or brake cable locations do not interfere with Aeon spring.

Use nut #9 at offset holes where required to position Aeon over axle.

If OEM vehicle has a peg style casting as shown, Timbren Aeon® rubber spring is designed to contact peg. Do not remove OEM peg.

Do not exceed vehicle manufacturer's recommended axle weight rating. Check for AEON® interference with vehicle components - Under load AEON® will "expand" in diameter.

Ref. = Reference
Part = Part #.
Qty. = Quantity

Ref	Part	Qty
1	F11061-150	2
2	F41034-050	4
3	F40031-020	2
4	K10327-003	2
5	A25722-90P00	2
6	A00535-65Q30	2
7	F11065-150	2
8	F11063-150	2
9	F31003-150	2

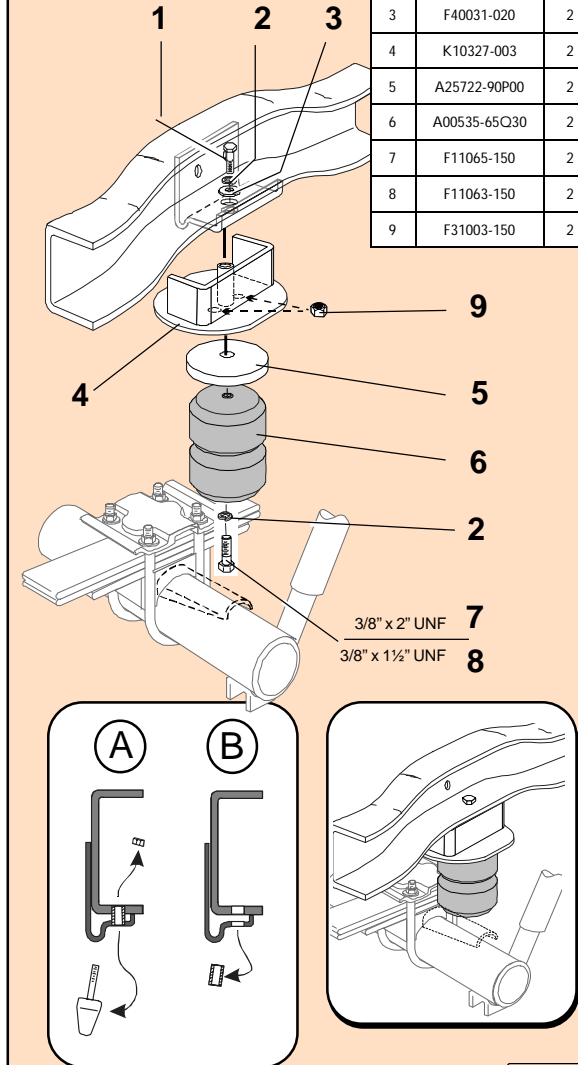

3/8" x 2" UNF 7
3/8" x 1 1/2" UNF 8



Ride Quality Control

TIMBREN SES

Suspension Enhancement Systems

Limited Lifetime Warranty

TIMBREN SES kits are warranted against defects in material and workmanship, under normal use and service, for the life of the vehicle on which the kit was originally installed. The warranty is not transferable and proof of purchase is required. The warranty is limited to the replacement of the failed part. TIMBREN will not be responsible for any labour or freight charges involved in the replacement of any product. TIMBREN shall be entitled to make its own inspection to determine the validity of the warranty claim. TIMBREN shall not be liable nor warrant the product in the event of alteration, misuse, overload, negligence or damage caused by others.

Clearance Instructions

Typical Light Duty & Medium Duty Installation

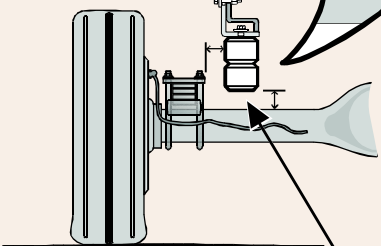
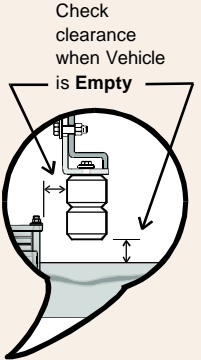

Be sure Rubber spring is seated directly over lower support.

Typical Heavy Duty Installation

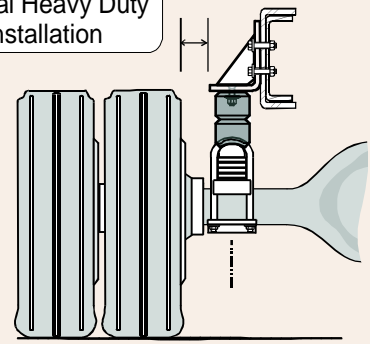

For Light Duty Pickups & Vans

Rear SES kits should have approximately 1" gap between rubber spring and axle for 1/2 and 3/4 tons, and for one on the gap should be about 1/2" when the vehicle is completely unloaded. A cap or fifth wheel plate will reduce or eliminate this gap.

Front SES kits are usually in contact with the front suspension at all times.

For Medium Duty & Heavy Duty Trucks, Trailers, Motor Homes, and more

Medium & Heavy Duty vehicles often have pre-load as outlined in the instruction sheet. (For specific Medium Duty applications with a constant load on the suspension like Rvs, Utility Vans or Cube Vans, the Timbren SESkits are pre-loaded.)

Check clearances when vehicle is empty...

Consider Your Needs..!

Knowing the use of the vehicle will help you to select the right SES kit. For example a one ton truck can be configured as a pick-up, service vehicle or tow truck. Standard capacity or severe service applications are available for many applications.

Knowing that the suspension has been modified or is old and sagging should indicate the need to adjust the ride height to obtain the correct clearance.

This can be done by altering the SES kit (changing rubber spring or bracket) or re-arching the leaf springs to renew the optimum OEMrideheight.

Timbren Industries Inc. ©