

DRTT3500E

DODGE

Rear suspension package

INSTALLATION INSTRUCTIONS

- Raise vehicle allowing the axle to hang freely.
- Remove existing bump stop.
- Assemble Aeon rubber spring and bracket as shown in the adjacent diagram.
- Mount Timbren assembly using OEM fasteners.
- Lower vehicle.

NOTES

Rubber washer #2 & bolt #6 may be used to achieve desired ride height. When removing OEM fasteners, use penetrating fluid.

Do not exceed vehicle manufacturer's recommended axle weight rating. Check for AEON® interference with vehicle components - Under load AEON® will "expand" in diameter.

Ref. = Reference
Part = Part #.
Qty. = Quantity

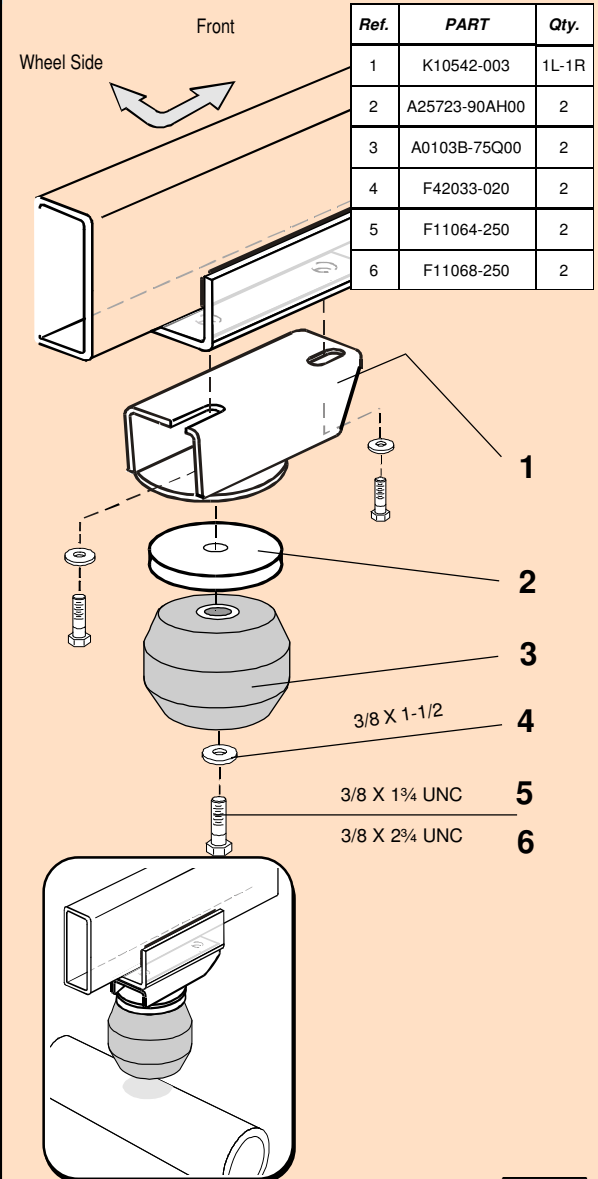

DRTT3500E

PART NUMBER	DESCRIPTION	QTY	LOCATION
F11064-250	HCS 3/8 x 1-3/4 UNC GR5 Z	2	G3D
F11068-250	HCS 3/8 x 2-3/4 UNC GR5 Z	2	G3C
F42033-020	WASHER FENDER 3/8 x 1-1/2 x 1/16 THK GR 2 Z	2	G4A

A0103B-75Q00	Hollow Rubber Spring	2	C1A
A25723-90AH00	RUBBER SPACER 4"od x 1" thk w/ AH Bushing	2	

K10542LH-003	DRTT3500E WELDMENT	1	D19F
K10542RH-003	DRTT3500E WELDMENT	1	D19F

B90201-CR	LARGE REAR BOX - 10.5 x 8.5 x 6	1	A--D
B10000	8" x 12" BUBBLE FOR KITS	1	
B00029-010	BARCODE LABEL FOR KIT	1	

ASSEMBLY NOTES:

APPLY LEFT/FRONT LABEL TO L/H BRACKET

Clearance Instructions:

Rear SES Kits for Pick-Ups and Vans should have a 1/2" to 1-1/2" gap between the rubber spring and contact point when empty.

A partial load, or vehicle accessories will reduce or eliminate the gap.

Front SES kits are usually in full contact.

Medium and Heavy-Duty Trucks, Trailers and Motorhomes will be in constant contact, and have no gap.