

TORTTN

Rear suspension package

INSTALLATION INSTRUCTIONS

- Partially raise vehicle not allowing the axle to hang freely.
- Loosen axle U-bolts and remove existing bump stop.
- Assemble Aeon rubber spring and bracket as shown in the adjacent diagram.
- Mount Timbren assembly on top of OE leaf pack & retighten U-bolts as per OEM specifications.
- Lower vehicle.

Do not exceed vehicle manufacturer's recommended axle weight rating. Check for AEON® interference with vehicle components - Under load AEON® will "expand" in diameter.

Ref. = Reference
Part = Part #.
Qty. = Quantity

Ref	Part	Qty
1	F11539-350	2
2	F42033-020	2
3	A0103B-65Q00	2
4	K10263-003	2

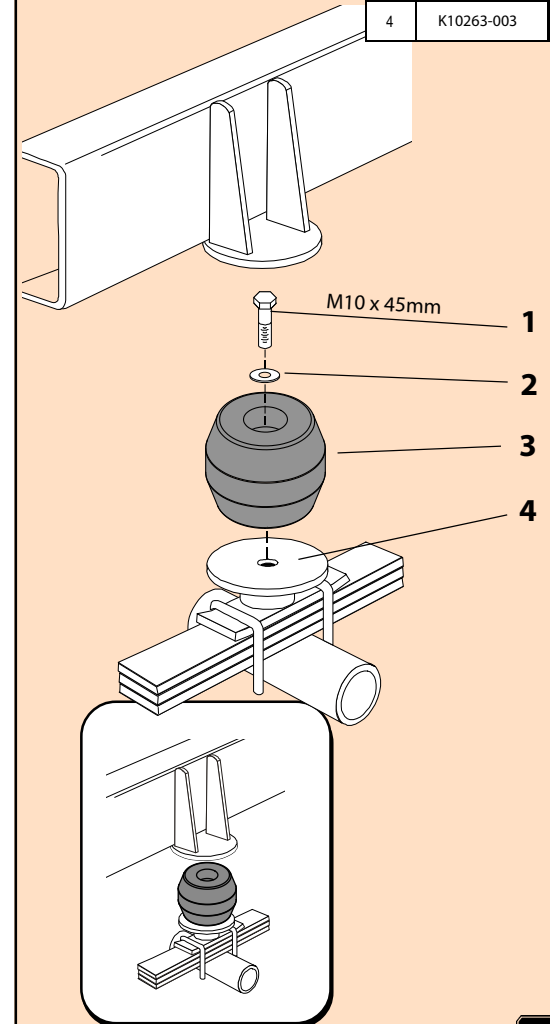

TORTTN



TORTTN

PART NUMBER	DESCRIPTION	QTY	LOCATION
F11539-350	HCS M10 x 45 x 1.5 GR 8.8 Z	2	I1C
F42033-020	WASHER FENDER 3/8 x 1-1/2 GR 2 Z (#3)	2	G4A

A00103B-65Q00	Hollow Rubber Spring	2	C1B
----------------------	----------------------	----------	------------

K10263-003	NRTTN / TORTUN4 WELDMENT PAINTED	2	D13B
-------------------	----------------------------------	----------	-------------

B90200-CR	SMALL REAR BOX - 9.5 x 7 x 5.5	1	A--E
B10000	8" X 12" BUBBLE FOR KITS	1	
B00029-010	BARCODE LABEL FOR KIT	1	

ASSEMBLY NOTES:

Issued:

Clearance Instructions:

Rear SES Kits for Pick-Ups and Vans should have a 1/2" to 1-1/2" gap between the rubber spring and contact point when empty.

A partial load, or vehicle accessories will reduce or eliminate the gap.

Front SES kits are usually in full contact.

Medium and Heavy-Duty Trucks, Trailers and Motorhomes will be in constant contact, and have no gap.

TORTTNL

INSTALLATION INSTRUCTIONS

- a) Partially raise vehicle not allowing the axle to hang freely.
- b) Loosen axle U-bolts and remove existing bump stop.
- c) Assemble Aeon rubber spring and bracket as shown in the adjacent diagram.
- d) Mount Timbren assembly on top of OE leaf pack & retighten U-bolts as per OEM specifications.
- e) Lower vehicle.

Do not exceed vehicle manufacturer's recommended axle weight rating. Check for AEON® interference with vehicle components - Under load AEON® will "expand" in diameter.

Ref. = Reference

Part = Part #.

Qty. = Quantity

Ref	Part	Qty
1	F31051-350	2
2	F42033-020	2
3	A0103B-55Q00	2
4	K10442-003	2
5	F12539-353	2

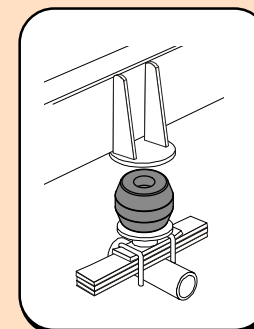
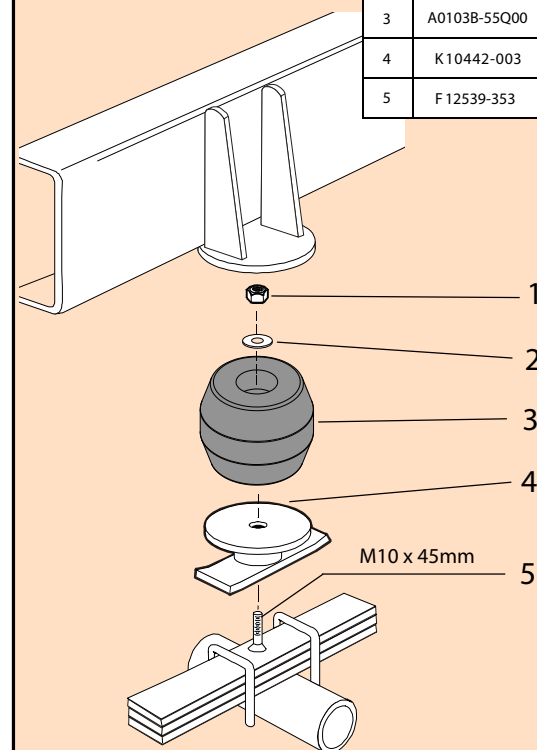

TORTTNL



TORTTNL

PART NUMBER	DESCRIPTION	QTY	LOCATION
F31051-350	NYLOCK LOCKNUT M10 x 1.5 GR 8.0 Z	2	I1D
F12539-353	FHSCS M10 x 45 x 1.5 Gr 8.8 B	2	J2B
F42033-020	WASHER FENDER 3/8 x 1-1/2 GR 2 Z (#3)	2	G4A
A0103B-55Q00	Hollow Rubber Spring	2	C1C
K10442-003	WELDMENT PAINTED	2	D21F
B90200-CR	SMALL REAR BOX - 9.5 x 7 x 5.5	1	A--E
B10000	8" x 12" BUBBLE FOR KITS	1	
B00029-010	BARCODE LABEL FOR KIT	1	

ASSEMBLY NOTES:

Issued:

Clearance Instructions:

Rear SES Kits for Pick-Ups and Vans should have a 1/2" to 1-1/2" gap between the rubber spring and contact point when empty.

A partial load, or vehicle accessories will reduce or eliminate the gap.

Front SES kits are usually in full contact.

Medium and Heavy-Duty Trucks, Trailers and Motorhomes will be in constant contact, and have no gap.

[View other performance suspension parts made by Timbren on our website.](#)