

# LRDR1A

# LAND ROVER

## Rear suspension package

### INSTALLATION INSTRUCTIONS

- Raise vehicle allowing the axle to hang freely.
- Remove existing bump stop assembly & retain fasteners.
- Assemble Aeon rubber spring and bracket as shown in adjacent diagram.
- Mount Timbren assembly using OEM fasteners.
- Lower vehicle.

### **NOTES:**

When removing OEM fasteners, use penetrating fluid.

Do not exceed vehicle manufacturer's recommended axle weight rating. Check for AEON interference with vehicle components - Under load AEON will "expand" in diameter.

Ref. = Reference  
Part = Part #.  
Qty. = Quantity

Ref	Part	Qty
1	A00100-65AG00	2
2	K11028-003	2
3	F41308-050	4
4	F11534-350	4

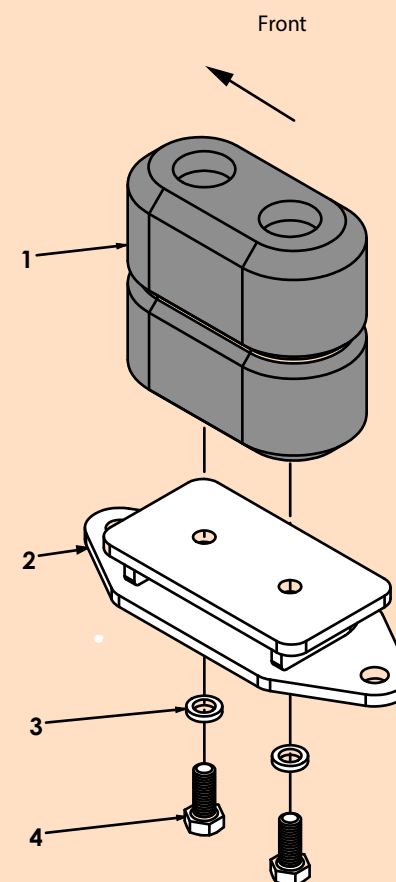

LRDR1A



## LRDR1A

PART NUMBER	DESCRIPTION	QTY	LOCATION
<b>F41308-050</b>	Lock Washer Split M10 Gr. 8.8 Z	<b>4</b>	<b>I1D</b>
<b>F11534-350</b>	HCS M10 x 25 x 1.5 Gr. 8.8 Z	<b>4</b>	<b>I1C</b>
<b>A00100-65AG00</b>	HOLLOW RUBBER SPRING	<b>2</b>	<b>C13B</b>
<b>K11028-003</b>	Weldment	<b>2</b>	<b>TBD</b>
<b>B90201-CF</b>	LARGE FRONT BOX - 10.5 x 8.5 x 6	<b>1</b>	<b>A--D</b>
<b>B10000</b>	8" X 12" BUBBLE FOR KITS	<b>1</b>	
<b>B00029-010</b>	BARCODE LABEL FOR KIT	<b>1</b>	

### ASSEMBLY NOTES:

Issued: 4/29/2019

#### Clearance Instructions:

Rear SES Kits for Pick-Ups and Vans should have a 1/2" to 1-1/2" gap between the rubber spring and contact point when empty.

A partial load, or vehicle accessories will reduce or eliminate the gap.

Front SES kits are usually in full contact.

Medium and Heavy-Duty Trucks, Trailers and Motorhomes will be in constant contact, and have no gap.