



FRTT350J

FORD

Rear suspension package

INSTALLATION INSTRUCTIONS

- Remove existing bump stop assembly & retain fasteners.
- Assemble Aeon rubber spring and bracket as shown in the adjacent diagram.
- Mount Timbren assembly using existing holes & OEM fasteners / shims.

NOTES

Use rubber washer #7 and bolt #5 to achieve desired ride height.

Check that brake line or brake cable locations do not interfere with Aeon spring.

If OEM vehicle has a peg style casting as shown, imbren Aeon® rubber spring is designed to contact peg.
Do not remove OEM peg.

Do not exceed vehicle manufacturer's recommended axle weight rating. Check for AEON® interference with vehicle components - Under load AEON® will "expand" in diameter.

Ref. = Reference
Part = Part #.
Qty. = Quantity

Ref	Part	Qty
1	OEM	4
2	K10552-003	2
3	A0103B-75Q00	2
4	F11538-350	2
5	F11543-350	2
6	K952354	4
7	A25723-90AH00	2
8	F42033-020	2

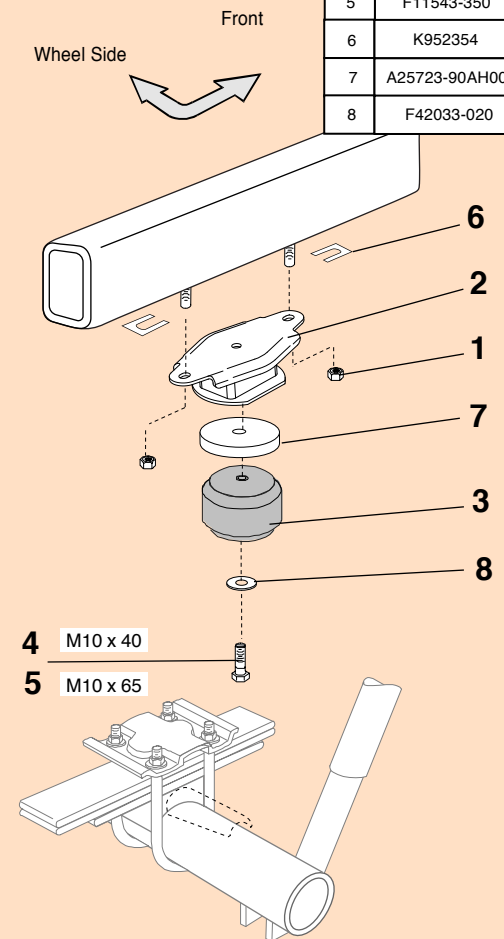

FRTT350J

FRTT350J

PART NUMBER	DESCRIPTION	QTY	LOCATION
F11538-350	HCS M10 x 40 x 1.5 Gr. 8.8 Z	2	I1C
F11543-350	HCS M10 x 65 x 1.5 Gr. 8.8 Z	2	I2D
F42033-020	WASHER FENDER 3/8 x 1-1/2 GR2 Z	2	G4A
K952354	SHIM 1-3/8" LNG x 1/8" WD x 1/32" THK x 5/8" SLOT W	4	P2C

A0103B-75Q00	Hollow Rubber Spring	2	C1A
A25723-90AH00	RUBBER SPACER 4"od x 1" thk w/ AH Bushing	2	

K10552-003	FR250SDJ/FR350SDJ/FRTT350G WELDMENT	2	
-------------------	-------------------------------------	---	--

B90201-CR	LARGE REAR BOX - 10.5 x 8.5 x 6	1	A--D
B10000	8" x 12" BUBBLE FOR KITS	1	
B00029-010	BARCODE LABEL FOR KIT	1	

Clearance Instructions:

Rear SES Kits for Pick-Ups and Vans should have a 1/2" to 1-1/2" gap between the rubber spring and contact point when empty.

A partial load, or vehicle accessories will reduce or eliminate the gap.

Front SES kits are usually in full contact.

Medium and Heavy-Duty Trucks, Trailers and Motorhomes will be in constant contact, and have no gap.