

INSTALLATION INSTRUCTIONS

- Raise vehicle allowing the axle to hang freely.
- Remove existing bumpstop using 13 mm socket.
- Assemble Aeon rubber spring and bracket as shown in the adjacent diagram.
- Mount Timbren assembly using existing holes & Timbren supplied fasteners.
- Clamp Timbren bottom support onto axle using fasteners provided. Torque U-Bolt nuts to 30-35 ft. lb.
- Lower vehicle.

NOTES

Check that brake line or brake cable locations do not interfere with Aeon spring.

If necessary, use rubber washer #2 and bolt #5 to achieve desired ride height.

Do not exceed vehicle manufacturer's recommended axle weight rating. Check for AEON® interference with vehicle components - Under load AEON® will "expand" in diameter.

Ref. = Reference
Part = Part #.
Qty. = Quantity

Ref	Part	Qty
1	K10546-003	1L-1R
2	A25723-90AH00	2
3	A0103B-65Q00	2
4	F11538-350	2
5	F11543-350	2
6	F41308-050	2
7	F11536-350	2
8	K10249-003	2
9	K51389	2
10	F40031-020	4
11	F31003-250	4
12	F42033-020	2

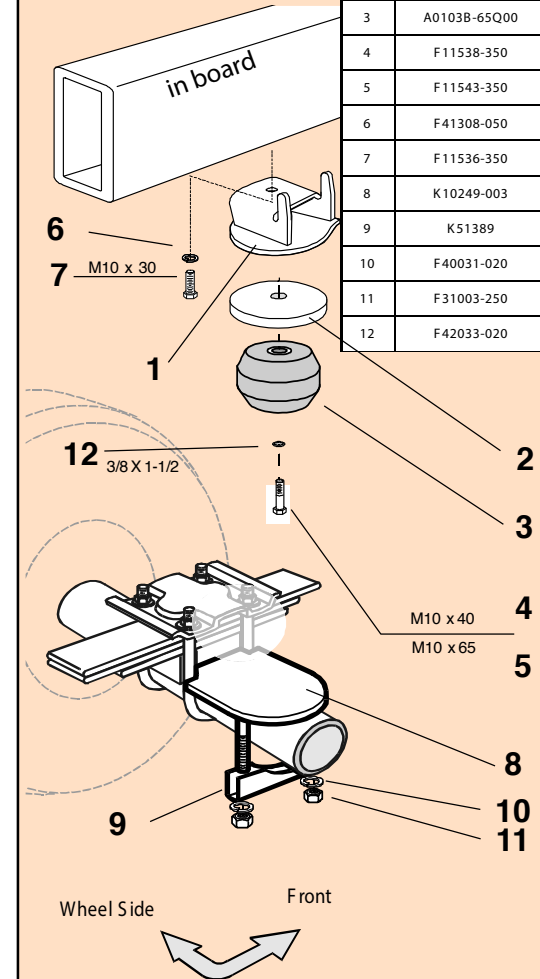

FRTT1504E

PART NUMBER	DESCRIPTION	QTY	LOCATION
F41308-050	WASHER SPLIT LOCK M10 GR 8.8 Z	2	I1D
F11536-350	HCS M10 x 30 x 1.5 GR 8.8 Z	2	I1C
F11538-350	HCS M10 x 40 x 1.5 GR 8.8 Z	2	I1C
F11543-350	HCS M10 x 65 x 1.5 GR 8.8 Z	2	I2D
F40031-020	WASHER FLAT USS 3/8 x 1 GR 2 Z	4	G1C
F31003-250	NYLOCK LOCKNUT 3/8 UNC GR 5 Z	4	G1B
F42033-020	WASHER FENDER 3/8 x 1-1/2 GR2 Z	2	G4A

A0103B-65Q00	Hollow Rubber Spring	2	C1B
A25723-90AH00	RUBBER SPACER 4"od x 1" thk w/ AH Bushing	2	

K10546LH-003	FR1504E WELDMENT LH PAINTED	1	D16F
K10546RH-003	FR1504E WELDMENT RH PAINTED	1	D16E
K10249-003	DODGE / FORD WELDMENT PAINTED	2	D2C
K51389	SADDLE CLAMP 3-1/2" DIA.	2	G5B

B90201-CR	LARGE REAR BOX - 10.5 x 8.5 x 6	1	A--D
B10000	8" x 12" BUBBLE FOR KITS	1	
B00029-010	BARCODE LABEL FOR KIT	1	

ASSEMBLY NOTES:

APPLY 'LEFT' LABEL TO L/H BRACKET

Clearance Instructions:

Rear SES Kits for Pick-Ups and Vans should have a 1/2" to 1-1/2" gap between the rubber spring and contact point when empty.

A partial load, or vehicle accessories will reduce or eliminate the gap.

Front SES kits are usually in full contact.

Medium and Heavy-Duty Trucks, Trailers and Motorhomes will be in constant contact, and have no gap.