



FRTR350HD

FORD

Rear suspension package

Ref. = Reference
Part = Part #.
Qty. = Quantity

INSTALLATION INSTRUCTIONS

- Raise vehicle allowing the axle to hang freely.
- Remove existing bump stop.
- Assemble Aeon rubber spring and bracket as shown in the adjacent diagram.
- Mount Timbren assembly using existing holes & Timbren supplied fasteners.
- Lower vehicle.

NOTES

Check that brake line or brake cable locations do not interfere with Aeon spring.

If necessary, use rubber washer #2 & bolt #5 may be used to achieve desired ride height.

If OEM vehicle has a peg style casting as shown, Timbren Aeon® rubber spring is designed to contact peg. Do not remove OEM peg.

Do not exceed vehicle manufacturer's recommended axle weight rating. Check for AEON® interference with vehicle components - Under load AEON® will "expand" in diameter.

Ref	Part	Qty
1	K10086-003	2
2	A25723-90AH00	2
3	A00540-65Q30	2
4	F11542-750	2
5	F11548-350	2

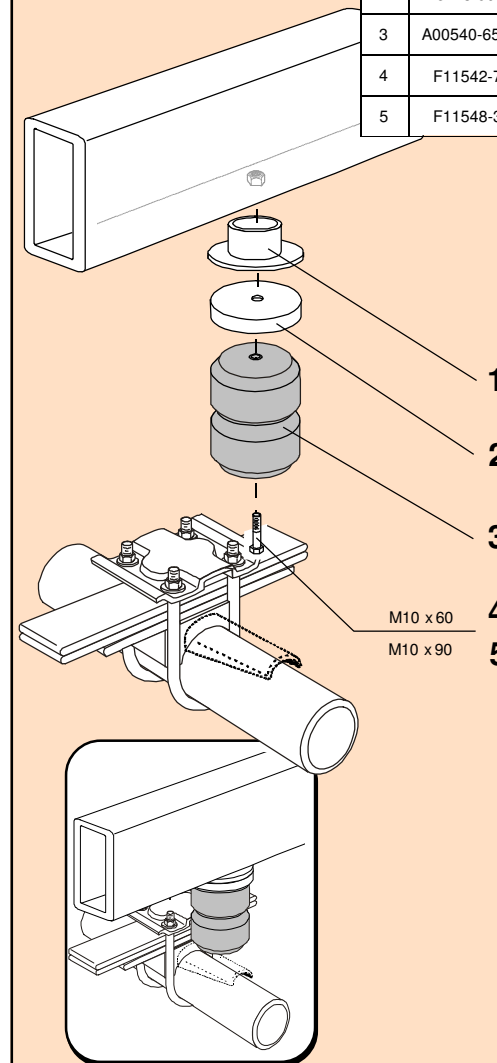

FRTR350HD

FRTR350HD

PART NUMBER	DESCRIPTION	QTY	LOCATION
F11542-750	HCS M10 x 60 x 1.5 F/T Gr 8.8 Z	2	I2D
F11548-350	HCS M10 x 90 x 1.5 Gr 8.8 Z	2	I2C

A00540-65Q30	Hollow Rubber Spring	2	C8B
A25723-90AH00	RUBBER SPACER 4"od x 1" thk w/ AH Bushing	2	

K10086-003	DDR1004 / GMRJB WELDMENT PTD.	2	D11B
-------------------	-------------------------------	----------	-------------

B90201-CR	LARGE REAR BOX - 10.5 X 8.5 X 6	1	A--D
B10000	8" x 12" BUBBLE FOR KITS	1	
B00029-010	BARCODE LABEL FOR KIT	1	

Clearance Instructions:

Rear SES Kits for Pick-Ups and Vans should have a 1/2" to 1-1/2" gap between the rubber spring and contact point when empty.

A partial load, or vehicle accessories will reduce or eliminate the gap.

Front SES kits are usually in full contact.

Medium and Heavy-Duty Trucks, Trailers and Motorhomes will be in constant contact, and have no gap.