

# ABSTOF

# TOYOTA

Front suspension package

## INSTALLATION INSTRUCTIONS

- Raise vehicle allowing the axle to hang freely.
- Where four bump stops exist, remove rear bumpstop.
- Mount Timbren assembly using existing holes & Timbren supplied fasteners.
- Lower vehicle.

### NOTES:

When removing OEM fasteners, use penetrating fluid.  
If OEM nut is damaged use Timbren supplied fastener #4

*Do not exceed vehicle manufacturer's recommended axle weight rating. Check for AEON® interference with vehicle components - Under load AEON® will "expand" in diameter.*

Ref. = Reference  
Part = Part #.  
Qty. = Quantity

### KIT PRE-ASSEMBLED

Ref	Part	Qty
1	A00140-65T00	2
2	A16060-003	2
3	F13536-853	2
4	F31051-450	2

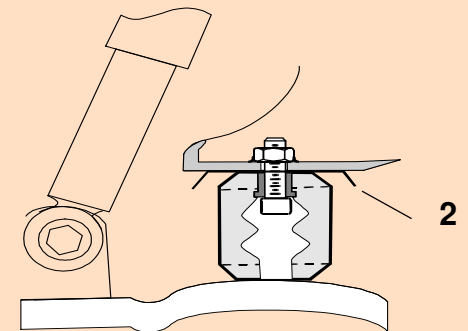
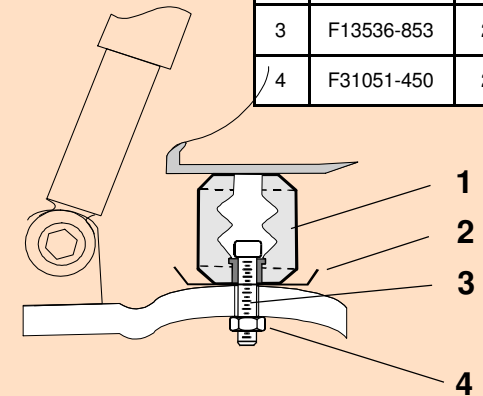

ABSTOF



# ABSTOF

TIMBREN INDUSTRIES INC.

## ASSEMBLY NOTES:

**PRE-ASSEMBLED KIT USE  
LOCTITE**

PART NUMBER	DESCRIPTION	QTY	LOCATION
<b>F31051-450</b>	NYLOCK LOCKNUT M10 x 1.25 GR 8.0 Z	<b>2</b>	<b>I1E</b>
<b>F13536-853</b>	SHCS M10 x 30 x 1.25 F/T GR 8.8 B	<b>2</b>	<b>J3D</b>
<b>A00140-65T00</b>	HOLLOW RUBBER SPRING	<b>2</b>	<b>C7E</b>
<b>A16060-003</b>	STEEL CUP 3 od x 13/32 id x 7/8" deep. Painted	<b>2</b>	<b>D21B</b>
<b>B90215</b>	Carton 8.5 x 6.5 x 5	<b>1</b>	<b>A5A</b>
<b>B10000</b>	8" x 12" BUBBLE FOR KITS	<b>1</b>	
<b>B00029-010</b>	BARCODE LABEL FOR KIT	<b>1</b>	
<b>B90121-010</b>	OFFROAD KIT BOX LABEL	<b>1</b>	

### Clearance Instructions:

Rear SES Kits for Pick-Ups and Vans should have a 1/2" to 1-1/2" gap between the rubber spring and contact point when empty.

A partial load, or vehicle accessories will reduce or eliminate the gap.

Front SES kits are usually in full contact.

Medium and Heavy-Duty Trucks, Trailers and Motorhomes will be in constant contact, and have no gap.