

# ABSNXF

Front suspension package

## INSTALLATION INSTRUCTIONS

- a) Raise vehicle allowing the axle to hang freely.
- b) Remove existing bump stop assembly.
- c) Mount Timbren assembly using existing holes & Timbren supplied fasteners.
- d) Lower vehicle.

### NOTES

Turn wheels full lock both directions to ensure there is no interference with Timbren assembly.

*Do not exceed vehicle manufacturer's recommended axle weight rating. Check for AEON® interference with vehicle components - Under load AEON® will "expand" in diameter.*

Ref. = Reference  
Part = Part #.  
Qty. = Quantity

Ref	Part	Qty
1	F11536-350	2
2	F41308-050	2
3	F40310-020	2
4	A16060-003	2
5	A00140-65AG00	2

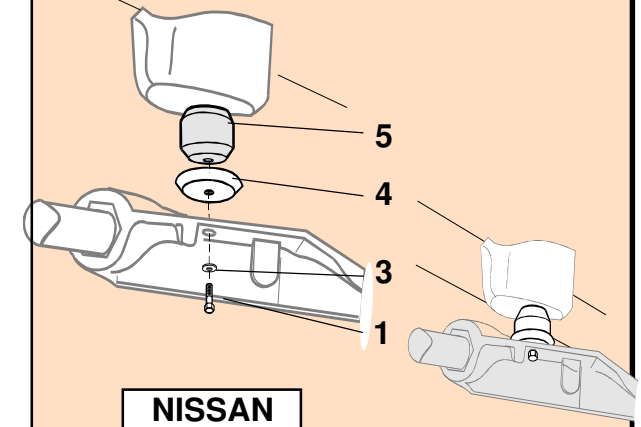
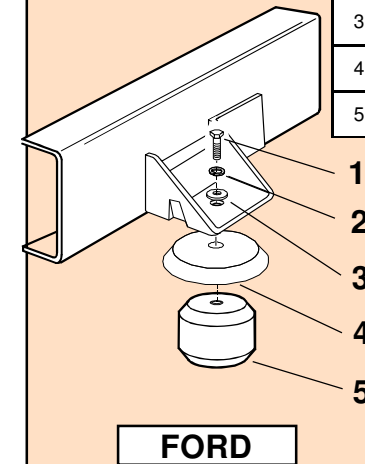

ABSNXF



PART NUMBER	DESCRIPTION	QTY	LOCATION
<b>F40310-020</b>	WASHER FLAT M10 GR 4.6 Z	<b>2</b>	<b>I1D</b>
<b>F41308-050</b>	WASHER SPLIT LOCK M10 GR 8.8 Z	<b>2</b>	<b>I1D</b>
<b>F11536-350</b>	HCS M10 x 30 x 1.5 GR 8.8 Z	<b>2</b>	<b>I1C</b>

<b>A00140-65AG00</b>	HOLLOW RUBBER SPRING	<b>2</b>	<b>C7F</b>
----------------------	----------------------	----------	------------

<b>A16250-003</b>	DISC 2-1/2 OD x 13/32 ID x 3/16 THK	<b>2</b>	<b>E(END)A</b>
<b>A16060-003</b>	STEEL CUP 3 od x 13/32 id x 7/8" deep. Painted	<b>2</b>	<b>D21B</b>

<b>B90215</b>	Carton 8.5 x 6.5 x 5	<b>1</b>	<b>A5A</b>
<b>B10000</b>	8" x 12" BUBBLE FOR KITS	<b>1</b>	
<b>B00029-010</b>	BARCODE LABEL FOR KIT	<b>1</b>	
<b>B90121-010</b>	OFFROAD KIT BOX LABEL	<b>1</b>	

**Clearance Instructions:**

Rear SES Kits for Pick-Ups and Vans should have a 1/2" to 1-1/2" gap between the rubber spring and contact point when empty.

A partial load, or vehicle accessories will reduce or eliminate the gap.

Front SES kits are usually in full contact.

Medium and Heavy-Duty Trucks, Trailers and Motorhomes will be in constant contact, and have no gap.