

# ABSJRJK

# JEEP

Rear suspension package

## INSTALLATION INSTRUCTIONS

- a) Raise vehicle allowing the axle to hang freely.
- b) Remove existing bump stop by prying out of bump stop cup.
- c) Position Aeon spring assembly into bump stop cup. Push and twist simultaneously. Ensure the assembly is fully seated in cup.
- d) Lower vehicle.

### NOTES

Ensure Timbren assembly is properly seated in bump stop cup.

*Do not exceed vehicle manufacturer's recommended axle weight rating. Check for AEON® interference with vehicle components - Under load AEON® will "expand" in diameter.*

Ref. = Reference

Part = Part #.

Qty. = Quantity

### KIT PRE-ASSEMBLED

Ref	Part	Qty
1	A25728-90AG00	2
2	A16060	2
3	A00525-65AG00	2
4	F13534-783	2

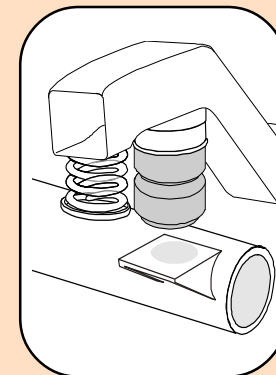
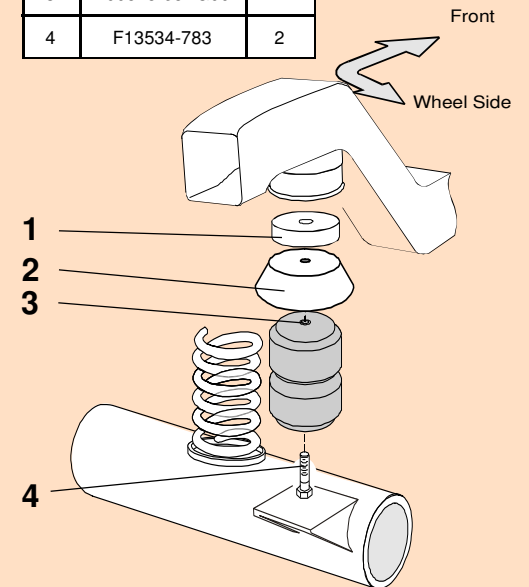

ABSJRJK



# ABSJRJK

TIMBREN INDUSTRIES INC.

## ASSEMBLY NOTES:

**PRE-ASSEMBLED KIT USE  
LOCTITE**

PART NUMBER	DESCRIPTION	QTY	LOCATION
<b>F13534-783</b>	SHCS M10 x 25 x 1.5 F/T GR 10.9 B	<b>2</b>	<b>J1C</b>
<b>A00525-65AG00</b>	HOLLOW RUBBER SPRING	<b>2</b>	<b>C4D</b>
<b>A25728-90AG00</b>	AEON LOCATOR W/ AG BUSHING	<b>2</b>	<b>F1B</b>
<b>A16060</b>	STEEL CUP 3 od x 13/32 id x 7/8" deep	<b>2</b>	<b>D21B</b>
<b>B90215</b>	Carton 8.5 x 6.5 x 5	<b>1</b>	<b>A5A</b>
<b>B10000</b>	8" x 12" BUBBLE FOR KITS	<b>1</b>	
<b>B00029-010</b>	BARCODE LABEL FOR KIT	<b>1</b>	
<b>B90121-010</b>	OFFROAD KIT BOX LABEL	<b>1</b>	

### Clearance Instructions:

Rear SES Kits for Pick-Ups and Vans should have a 1/2" to 1-1/2" gap between the rubber spring and contact point when empty.

A partial load, or vehicle accessories will reduce or eliminate the gap.

Front SES kits are usually in full contact.

Medium and Heavy-Duty Trucks, Trailers and Motorhomes will be in constant contact, and have no gap.