

1. USE ONLY WITH DOT-3 OR DOT-4 BRAKE FLUID.
2. NO INTERNAL TRAVEL LIMITER. MUST BE USED WITH CLUTCH PEDAL STOP.
3. SEAL REBUILD KIT = 62-905.
4. SEAL INSTALLATION TOOL = 96-002.
5. HYDRAULIC AREA = 1.215 SQ IN.
6. EITHER PORT MAY BE USED FOR FEED OR BLEED.
7. ORIENTATE BLEED PORT TO WITHIN 10 DEGREES OF TOP CENTER TO FACILITATE BLEEDING PROCESS.
8. UNIT IS SHIPPED WITH SHIM 62-903 (.050" THICK) INSTALLED UNDER THE BEARING WHICH MAY BE REMOVED FOR ADDITIONAL CLEARANCE.
9. BOTH PORTS 3/8-24 UNF X .28 THREAD DEPTH.

ITEM	PART NUMBER	DESCRIPTION	QTY
1	62-402	HYDRAULIC BASE	1
2	62-617	WIPER	1
3	62-614	HYDRAULIC SEAL	1
4	73-820	FITTING, AN-3	2
5	SEE CHART	PISTON	1
6	62-031	BEARING	1
7	62-903	SHIM	1

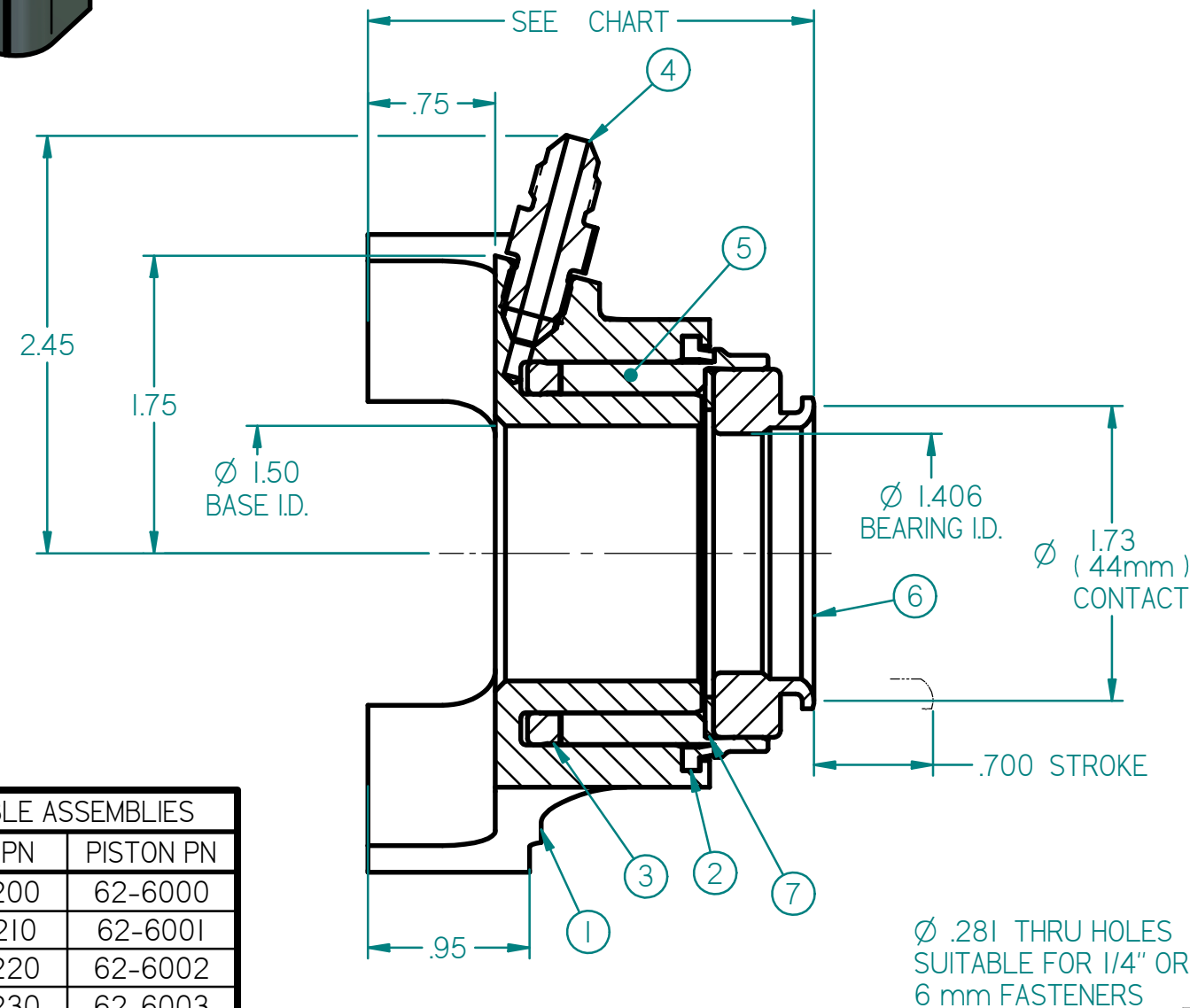

SECTION A-A

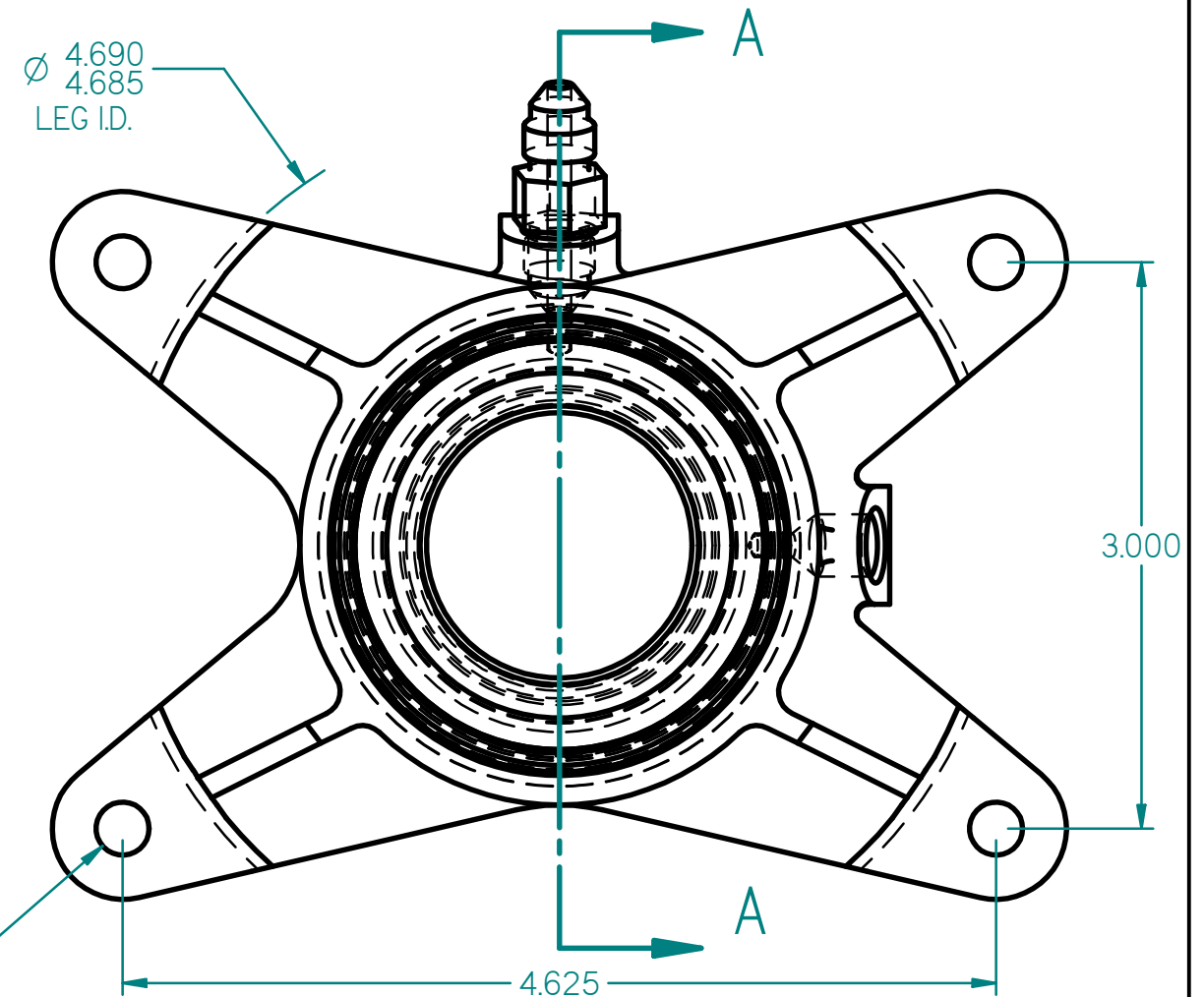

HEIGHT	ASSY PN	PISTON PN
2.57"-2.62"	60-4200	62-6000
2.67"-2.72"	60-4210	62-6001
2.77"-2.82"	60-4220	62-6002
2.87"-2.92"	60-4230	62-6003
2.97"-3.02"	60-4240	62-6004
3.07"-3.12"	60-4250	62-6005
3.17"-3.22"	60-4260	62-6006
3.27"-3.32"	60-4270	62-6007
3.37"-3.42"	60-4280	62-6008
3.47"-3.52"	60-4290	62-6009

* HEIGHTS SHOWN IN CHART ARE WITH AND WITHOUT 62-903 SHIM

TILTON ENGINEERING, INC.

TITLE: **HYDRAULIC RELEASE BEARING ASSEMBLY**
44 mm RADIUS FACED BEARING, 4 LEG BASE

DRAWN BY WAHL	CHKD LUND	SCALE 1:1	SIZE B	DWG 5605	REV NC
P/N SEE CHART	DATE 03/16/2012	SHEET 1 OF 1			