

Heavy-Duty High Performance 40000-Series

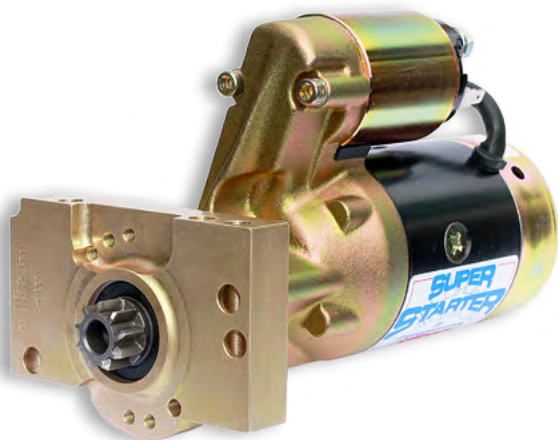

Motor Power: **3.0 HP (2.2 kW)**
 Weight: **12.0 lbs**
 Rec. Engine Size: **More than 400 C.I.D.**
 Rec. Compression Ratio: **Over 11 : 1**

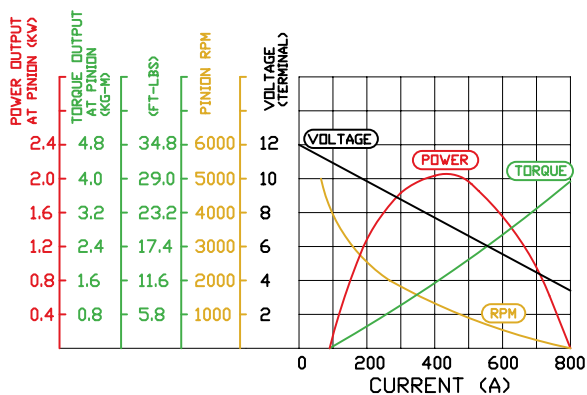

Application	Part Numbers	
Chevy V8 / 90 degree V6	153 / 168-tooth ring gear	54-40001
	104-tooth ring gear	54-40005
Ford 289/302/351W/390/427/428 engines, 1967-up		54-40013
Ford 351M/400/429/460 engines		54-40014
QM rear-mount starter bellhousing, 110-tooth ring gear		54-41052
Tilton rear-mount starter bellhousing, 105-tooth ring gear		54-41052
Tilton 52-Series UTGC rear-mount bellhousing, 102T ring gear		54-41062
Tilton 52-Series 7.25" bellhousing, 110-tooth ring gear	4 o'clock solenoid position	54-41547
	6 o'clock solenoid position	54-41047
	11 o'clock solenoid position	54-41647
VW-type transaxles transaxles (Albins, Fortin, Mendeola, etc)		54-41053



Powerful 3.0 HP motor and gear reduction provides high torque to start large, high compression engines.

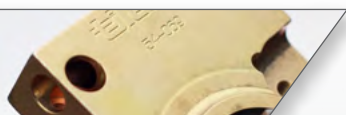

Precision machined components are held to critical tolerances, ensuring high performance and a perfect fit.

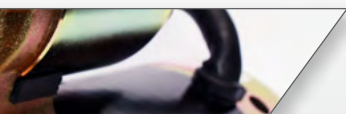

Internal vibration damping and electrical insulation provide longevity and maximum performance.

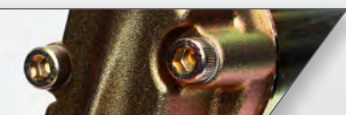

High-strength (grade 10.9) socket head fasteners ensure rigid assembly and easy access for hex keys.



Serrated Belleville lock washers are used to ensure fasteners stay in place through severe vibrations and heat cycles.



Thread locking compound is used on all fasteners and are secured to precise torque specifications.

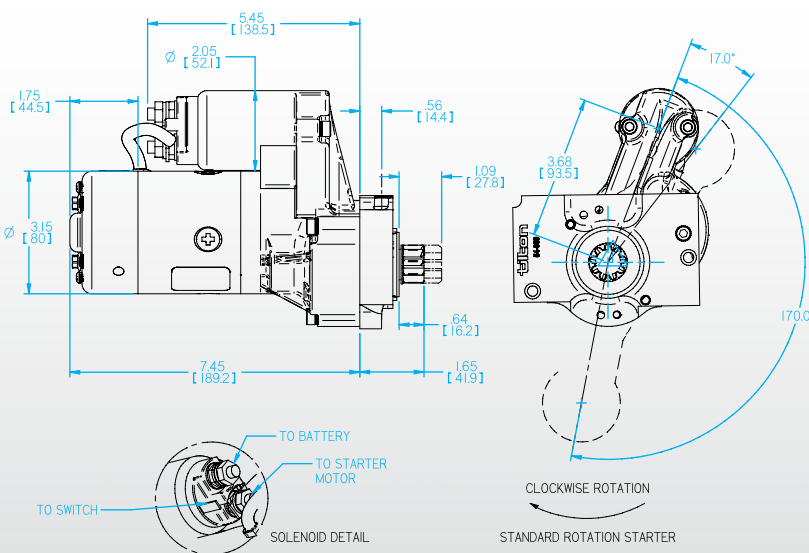

- NOTES:
- STARTER CAN BE INDEXED INTO THREE POSITIONS AS SHOWN
 - SET BACKLASH BETWEEN PINION AND RING GEAR TO .020" +/- .010"
 - CHECK FOR .100" +/- .040" PINION OFFSET FROM RING GEAR
 - 9 TOOTH, 12 PITCH PINION, .805" (20.45mm) PITCH DIAMETER
 - STARTER ASSY WEIGHS 11.2 LBS (5.1kg)
 - 3.0 HP, 2.2 kw MOTOR
 - CHEVY V8, SML & BIG BLK 153/168T FW
 - DIMENSIONS ARE NOMINAL