

Universal Pivot Pin Extractor

15060

**TIGER
TOOL**

Have What It Takes

Designed for use with 15000 Pin & Bushing Kit

Safety Warning

Read all instructions and safety warnings prior to operation. Failure to do so could result in equipment damage, personal injury, or even death.

CAUTION: USE REPLACEMENT PARTS AND ACCESSORIES PROVIDED BY TIGER TOOL ONLY. ALL REPLACEMENT PARTS AND ACCESSORIES ARE AVAILABLE. KEEP HYDRAULIC COUPLER PROTECTED WHEN NOT IN USE. DUST CAPS SHOULD BE USED ON COUPLERS WHEN NOT IN USE TO AVOID CONTAMINANTS FROM ENTERING THE HYDRAULIC CYLINDER AND POWER SOURCE. THIS PRACTICE WILL HELP TO EXTEND THE LIFE OF THIS PRODUCT AND ENSURE CONTINUED CONSISTENT OPERATION.

- **Stay Alert!** Watch what you are doing and use common sense when operating this tool.
- Inspect product for damage prior to using; do not use if product is in unsafe condition.
- Do not operate tool while under the influence of drugs, alcohol, or medication.
- Always use safety equipment to prevent injuries. Approved face and eye protection must always be worn by the operator, as well as others in the work area.
- Do not overreach, keep proper footing and balance at all times.
- Dress properly. Do not wear loose clothing or jewelry. Keep your hair, clothing and gloves away from moving parts.
- Keep hands clear of all pressurized hydraulic components.
- Always ensure hoses are free from sharp bends and kinks.
- Keep your work area clean and well lit.



Universal Pivot Pin Extractor

15060

**TIGER
TOOL**

Have What It Takes

Designed for use with 15000 Pin & Bushing Kit

Operating Instructions

- 1 Begin by removing the retainer bolts. Use a tap to clean the threaded area inside the bracket pin. **Figures 1 & 2.**
- 2 Bolt the hammer adapter into the center threaded hole of the bracket pin and strike it to shock it loose from the 5th wheel. Clean any rust, paint, or scale from the head of the bracket pin to create a clean metal surface for welding. **Figures 3 & 4.**
- 3 There are two weld-on adapter sizes included in the kit. ($\frac{1}{2}$ " , $\frac{5}{8}$ ") Each adapter has a centering nub on the mating side to ensure proper alignment during the welding process. Weld the corresponding adapter to the bracket pin and then thread the coupler adapter onto the weld-on adapter. Next, thread the draw bar into the coupler adapter. **Figures 5 & 6.**
- 4 Slide the aluminum spacer tube and cylinder assembly over the threaded draw bar and install the washer and hex nut. Apply hydraulic pressure ensuring hands and body are not in line with the cylinder and threaded draw bar. **Figure 7.**
- 5 Once cylinder has reached the end of its stroke (2") release hydraulic pressure allowing the piston to retract. Then spin up the hex nut and apply hydraulic pressure once again. Repeat as necessary until pin is removed. **Figure 8.**

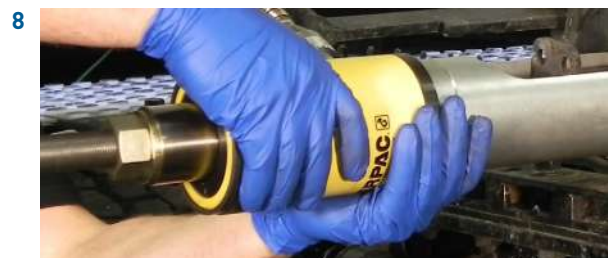

Universal Pivot Pin Extractor

15060



Have What It Takes

Designed for use with 15000 Pin & Bushing Kit

Parts Breakdown

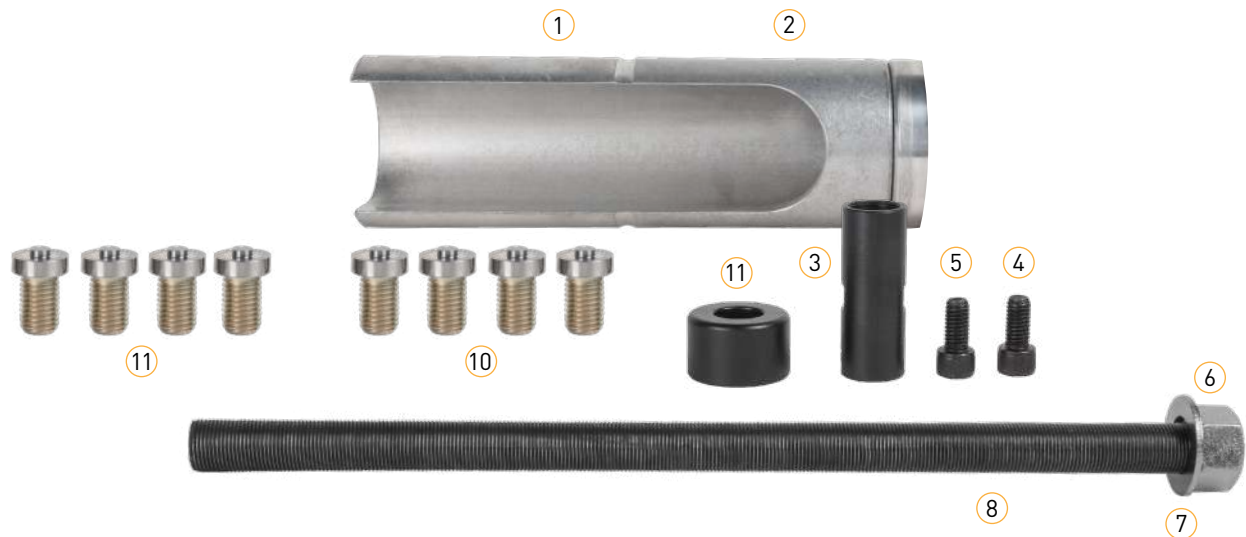

Item No.	Part Number	Description	Qty.
1	10705-1	Spacer Tube	1
2	10705-2	Cylinder Adaptor	1
3	10705-3	Bolt Adaptor	1
4	10705-8	3/4" x 0.875"	1
5	10705-7	1/2" x 0.875"	1
6	15001-41	Hex Nut	1
7	15001-42	Washer	1
8	15001-40A	18" Draw Bar	1
9	10705-5	5/8" Adaptor	1
10	10705-4	1/2" Adaptor	4
11	10705-6	Hammer Adaptor	4

Check out the collection of pullers and installers we offer.