

PARTS INCLUDED

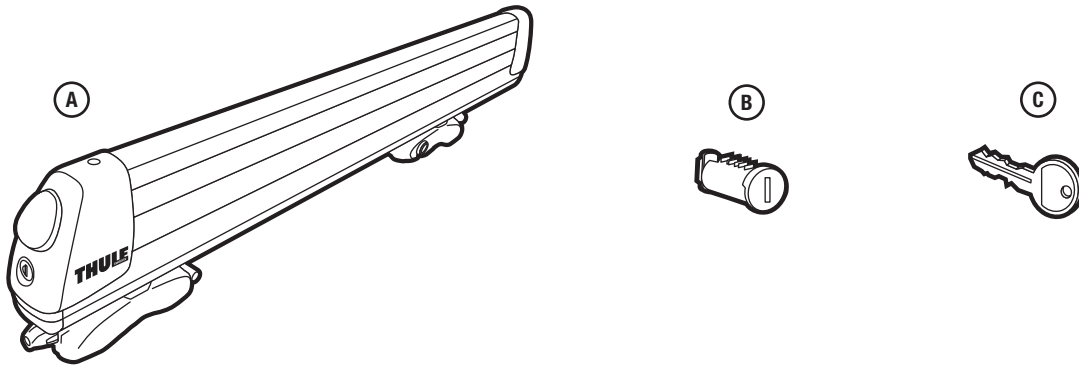

part	description	part number	qty.
A	92726 (6 pair fat ski carrier)	—	2
B	lock cylinder	—	4
C	locking key	—	2

1

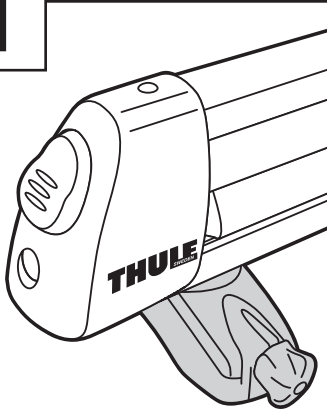

- Rotate Speed-Link™ mounting hardware 90 degrees

2

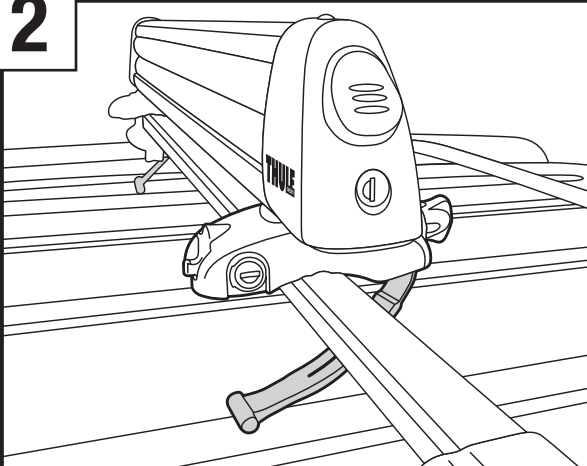

- Position ski carrier across load bar or factory cross bar so one Speed-Link is toward the driver's side and one SpeedLink is toward the passenger's side.

C RRECT	INC RRECT
	
<p>WARNING: Skis need to ride front to back on the vehicle, not side to side.</p>	

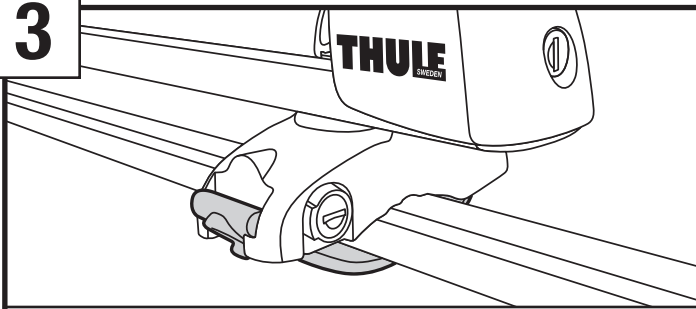
3

- Wrap Speed-Link rubber strap under load bar and place T-end into pocket on end. Repeat with other 3 Speed-Link straps.

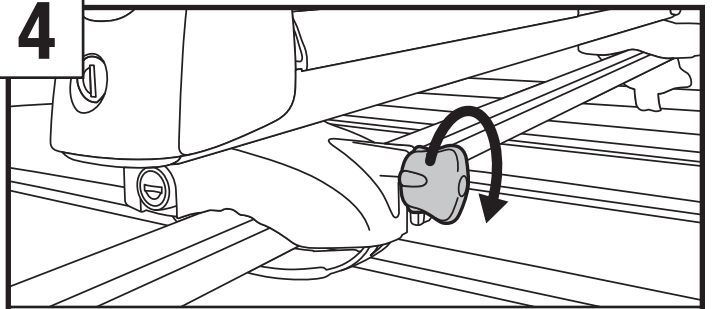
4

- Tighten all 4 knobs firmly.
- Test security by pushing and pulling on carriers.

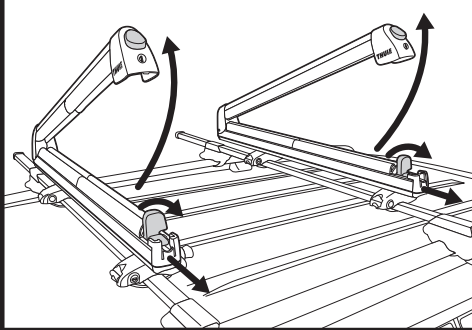
5**SKI CARRIER USE**

- Push button and lift open carrier arm. Push lever to the side. Grab ski carrier top and slide over side of vehicle.

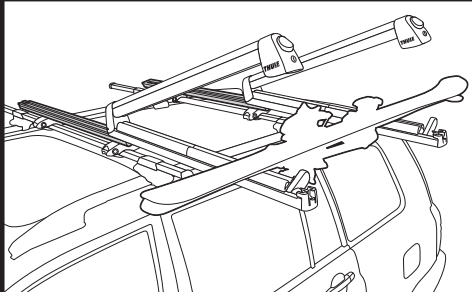
(A)

- Mount skis into the carrier with the tips facing to the rear. Mount snowboards with bindings in the closed position.

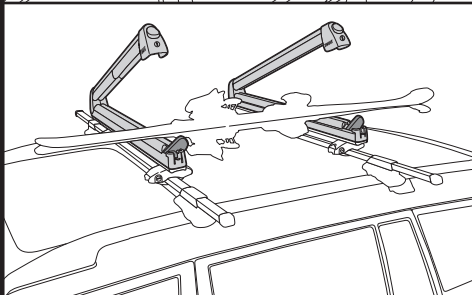
(B)

- Slide carrier back over vehicle roof.

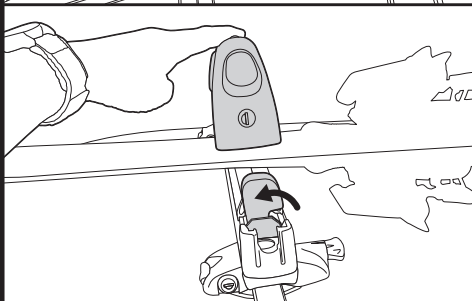
(C)

- Lift lever back to upright position and close carrier arm.

(D)

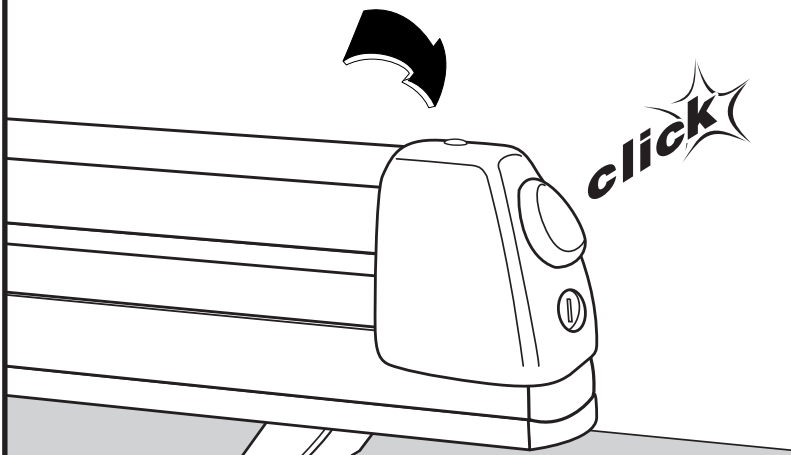

E

- To close the carrier, push the hood down until the latch clicks securely. The latch is designed with two settings to accommodate varying thicknesses of skis or snowboards.

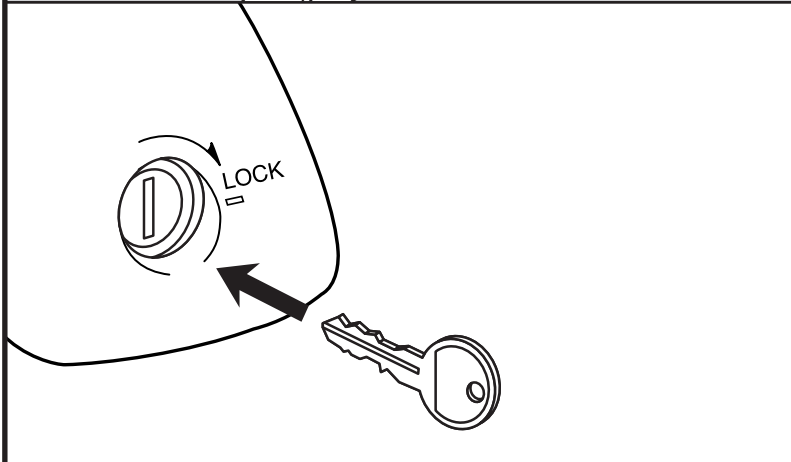

F

- Turn key to horizontal position to lock.
- Test security by pushing up on hood.

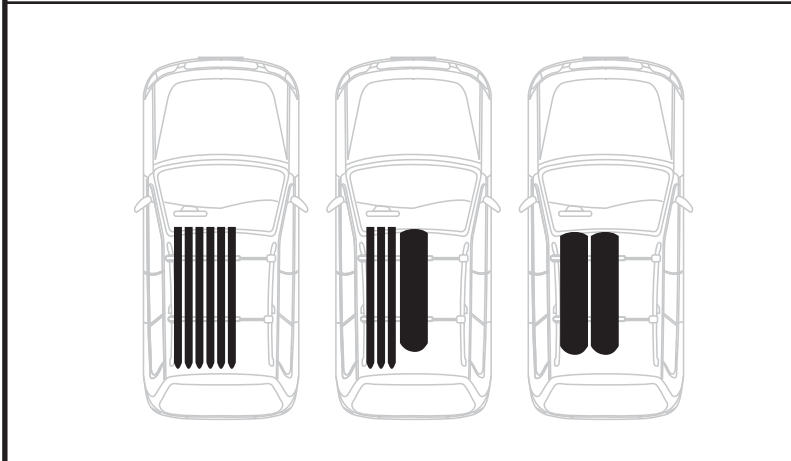

G

- Maximum load: 6 pair skis or 4 snowboards.

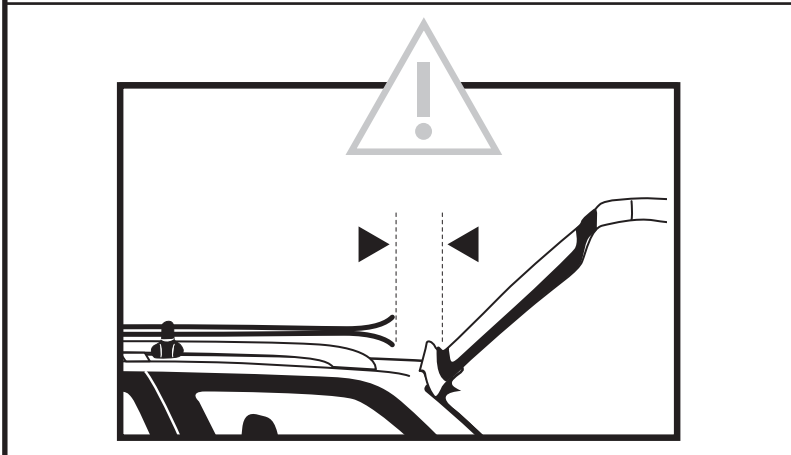

H

- This carrier is designed only for skis and snowboards. Check that the skis do not strike against the luggage hatch.