

# TOP-TRACKS WITH FLARENUTS

## PARTS INCLUDED

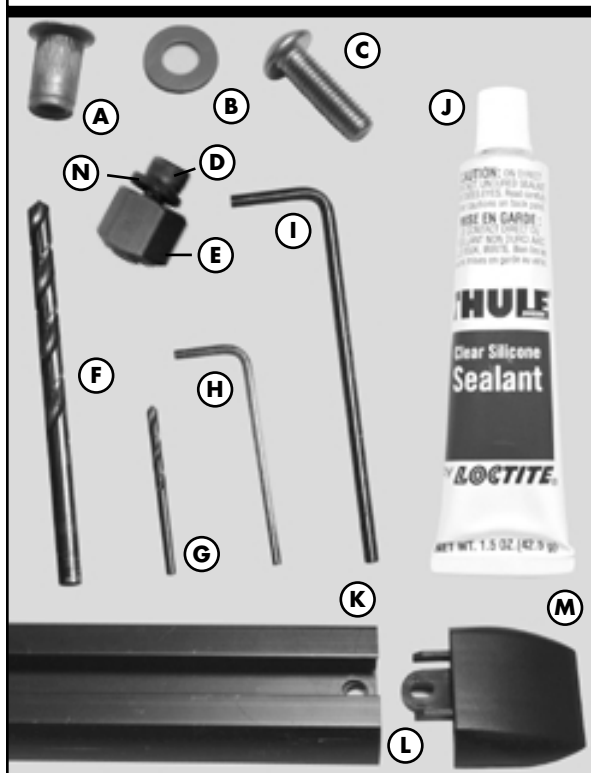

part	description	part number	qty.
A	flare nut insert M5/	853-5363	16
B	nylon washer M5/	853-5367	16
C	screw M5 x 16mm/	924-0516-20	16
D	screw M5 x 25mm/	919-0525-11	1
E	blind insert tool nut/	853-5362	1
F	N size drill bit (0.302)/	853-5369	1
G	1/8" drill bit/	853-5369-03	1
H	3mm hex key/	853-0947	1
I	4mm hex key/	853-2430-02	1
J	silicone sealant/	853-5374	1
K	track/	853-5359-xx	2
L	vinyl roof protector/	853-5360-xx	2
M	track end cap/	853-5361	4
N	steel washer M5/	951-0510-11	1

## COMPATIBILITY AND RESTRICTIONS

- Installation of Top-Tracks™ requires drilling the roof and permanently installing parts.
- Tools and some mechanical skills are required. If concerned about installation, have tracks installed by professional installer.
- Not for off road use.
- Do not install if roof has had bodywork.
- Do not install on vehicles with sunroofs.
- Do not install on vehicles with factory racks.

## TOOLS REQUIRED (NOT INCLUDED)

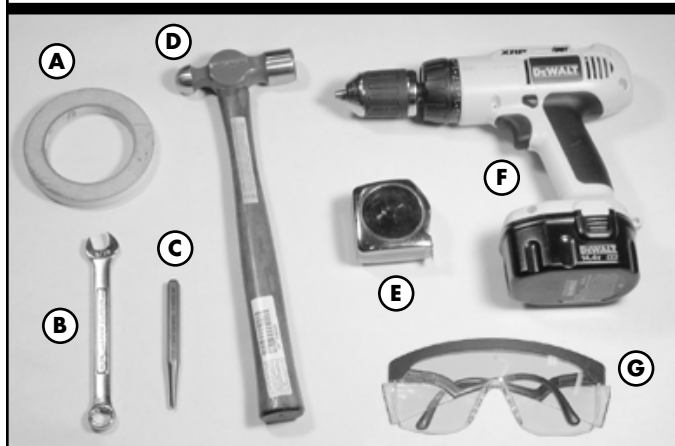

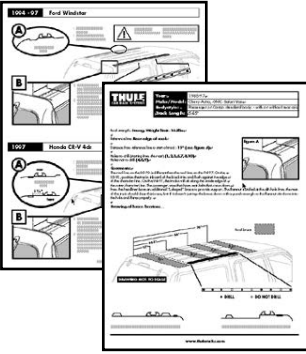

part/	description/
A	masking tape/
B	3/8" wrench/
C	center punch/
D	hammer/
E	tape measure/
F	electric drill/
G	safety glasses/

- REFER TO THE TRACK FIT SHEET for track placement and important details about your vehicle.

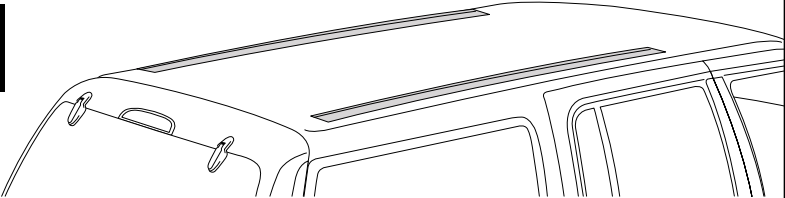
- Align tracks to each other and position track ends equal distance from reference line on vehicle.
- Make certain holes in roof protector are aligned with holes in track.





- Using the track as a guide, center punch in center of rear hole.

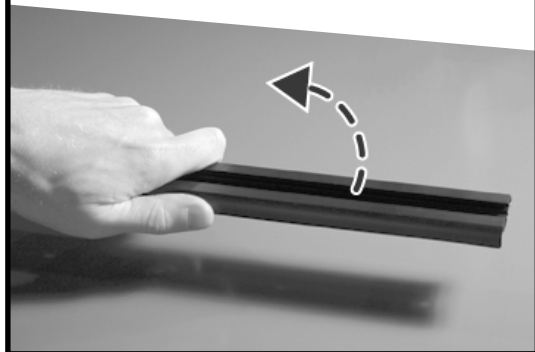

- Remove track from roof.

**NEVER DRILL THROUGH TRACKS!**







Wear safety glasses during installation.

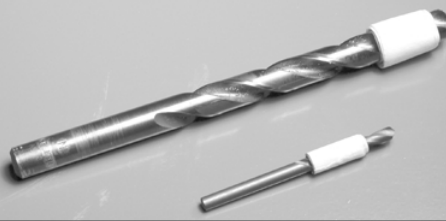

- Never drill deeper than 1/4".
- Use drill stop or wrap masking tape 1/4" from end of drill bits.

Wear safety glasses during installation.

- Using drill bit included, drill 1/8" pilot hole in center of mark.



**6a**



Wear safety glasses during installation.

- Drill N size hole (0.302") with bit supplied into pilot hole.



**6b**

- Carefully blow away debris.

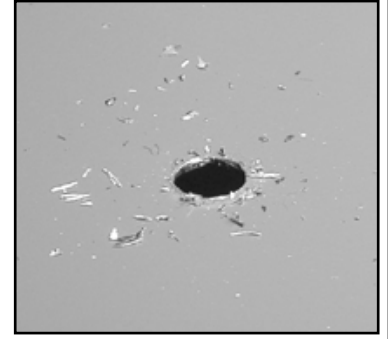

**7**

- Attach flarenut insert to M5 x 25mm screw, steel washer M5 and insert nut as shown.
- Note: Flat end of inset nut must face screw head.
- Fully thread insert onto screw.

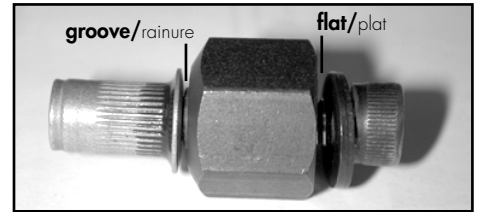

**8**

- Set into hole.
- While firmly holding nut with  $\frac{5}{16}$ " wrench, tighten screw.
- Tighten until there is a noticeable increase in the force.

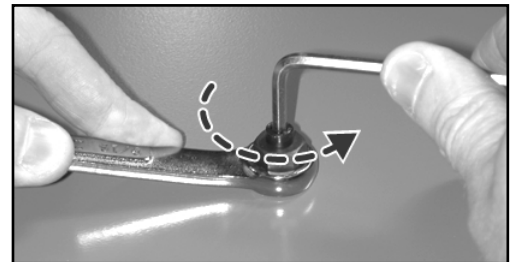
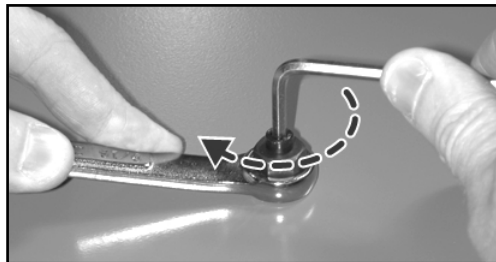

- Remove flaring tool by holding nut with  $\frac{5}{16}$ " wrench and turning screw counter clockwise.

**9**

- Place track on roof aligning hole in track with insert.

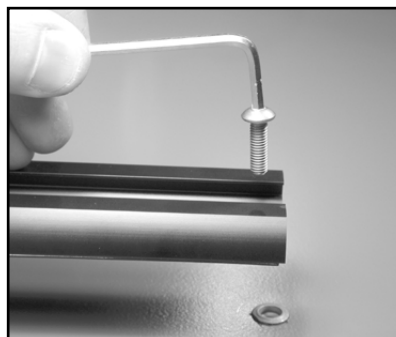

**10**

- Install bolt loosely.

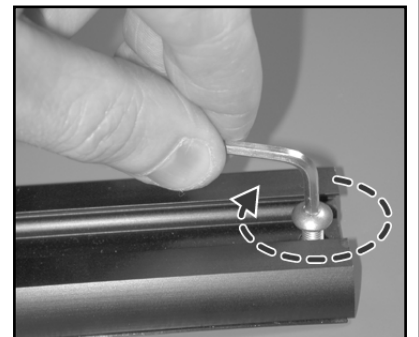

**11**

- Align track on roof and center punch in center of front hole.

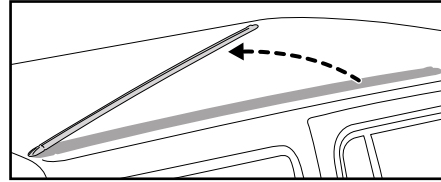
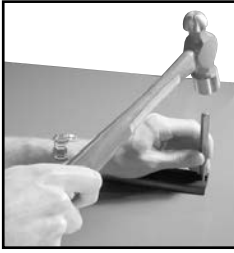

- Rotate track out of position.

- Repeat steps 5 through 10.

**12**

Note: Refer to track fit sheet for remaining holes to be centered punched and drilled. Center punch all remaining holes specified for your vehicle.

**13**

- Loosen screws from ends and remove track.

**14**

- Repeat steps 5 - 8 for each punched hole.

**15**

- Apply a "pea size" amount of silicone into each insert.



**16**

- With end caps inserted into track, position track over the holes and insert screws at the front and rear.

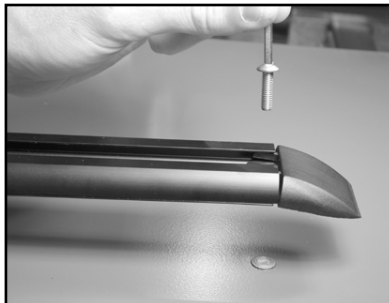

- Install screws with washers in remaining holes with inserts.

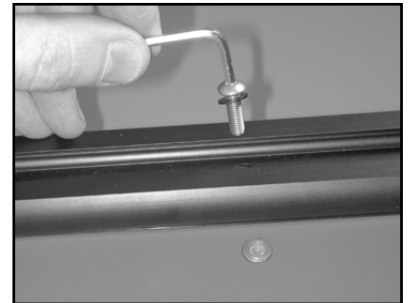

**Tighten all screws firmly**

**17**

- Repeat entire procedure for other side of vehicle.

**Note: Extra parts are common because not all holes will be used.**

**Note: For mounting TK1 bases (not included), use all hardware (thick washer, thin washer, spacer) included with TK1.**