

**Installation Manual**

SKU# 29055XT Van Double

SKU# 29056XT Van Triple



**WARNINGS / LIMITATIONS**

- Do not exceed vehicle manufacturer's load limits.
- If used in conjunction with another type of load carrying system the lower weight capacity of the two systems should be followed.
- Tie down front and rear of all long loads to the vehicles bumpers for safe transport.
- Install parts as shown on illustrations.
- Carrying high loads over rough roads with excess speed may damage the system. Good judgment must be exercised at all times.

Van installation is straightforward, and should take you under 20 minutes to complete. You'll attach the Crossbars to the Corner Brackets, then attach this assembly to the Gutter Rails of your van.

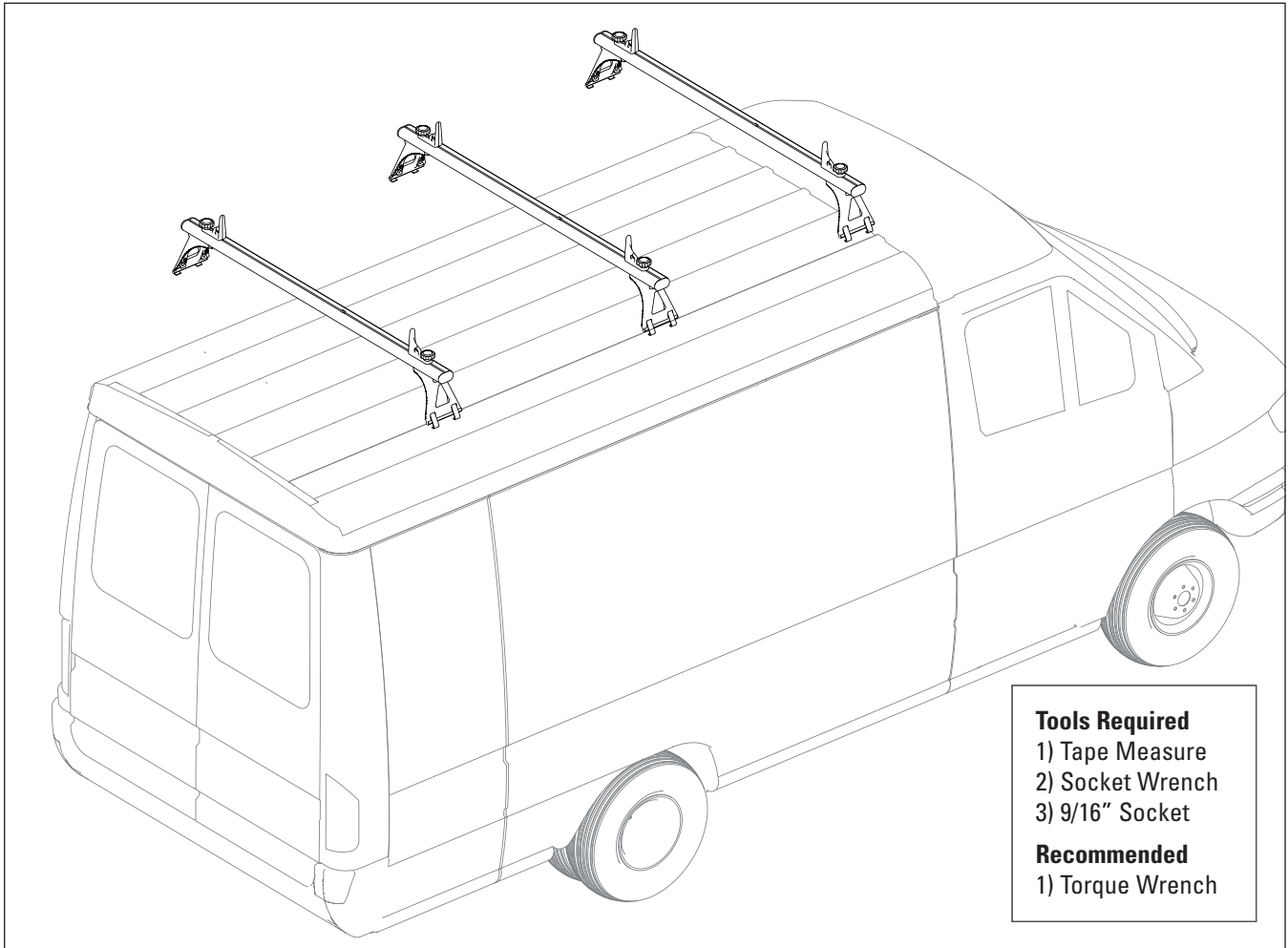

### Special Installation notes:

- All 1998+ Chevy Express / GMC Savanna (G-Series Vans) require the supplied Gutter Span, which are designed to span the putty filled rain gutter of the Van for maximum strength. If you use the supplied Gutter Spans, refer to "Roof Installation B" instructions on page 5 for proper installation.
- All 2000+ Ford Econoline Vans: DO NOT install the rubber strips to the Corner Brackets.
- When installing a Van Triple (SKU# 29056XT) to a Chevy Express / GMC Savana and Ford Vans with curved roofs, you'll need to add the supplied Shims, to compensate for the gutter's curve.

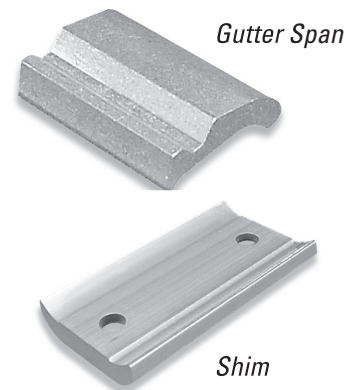

1. Fit the Rubber Strip on the lower edge of each Corner Bracket.

**Do not install strip:**

- On 2000+ Ford 150 Econoline vans.
- If using the Gutter Spans

2. Insert 2 (5/16" x 1 3/4" long) Socket Head Cap Screws through the Lock Washers and then into the holes in each Corner Bracket Tab. (See Fig. 1)

5. Attach a Corner Bracket assembly to the Crossbar by inserting the T-Bolts through the two holes in the Corner Bracket. Partially tighten and secure with the Self Locking Nuts – enough to hold the Corner Bracket in place. Repeat for each of the remaining three Brackets.

6. Slide the Crossbar Tiedowns onto the Crossbar by inserting the M8x26mm T-Bolts into the top Crossbar Slot.

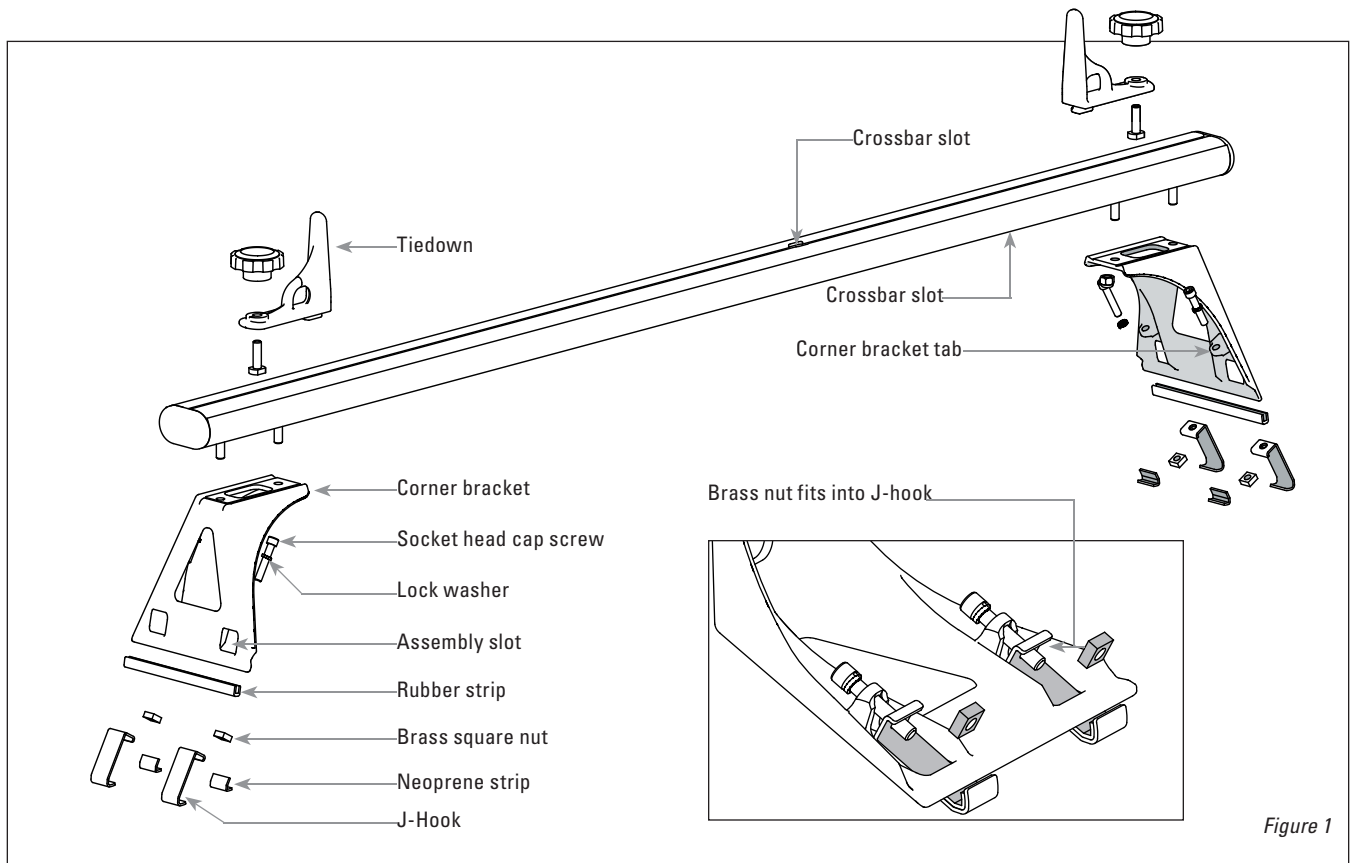

Figure 1

3. Insert the J-Hooks with Neoprene Strips through the Assembly Slots at the base of the Corner Bracket. Then insert 2 Brass Nuts into the opening of the J-Hook clips. Thread each screw approx. 1/4 in. into the J-hook's brass nut. (Do not completely tighten screws) Repeat for each Corner Bracket, (2 hooks for each Bracket). (See Fig. 1)

4. Now you're ready to attach the Crossbars (see Shim Installation, page 6, if shims are required on front and rear racks). Insert the heads of four 1 1/2" T-Bolts into the Crossbar Slot on the bottom of each Crossbar (the bottom is the side with the Flat Recess) (see Fig. 2). Slide 2 T-Bolts to the left side and 2 T-Bolts to the right.

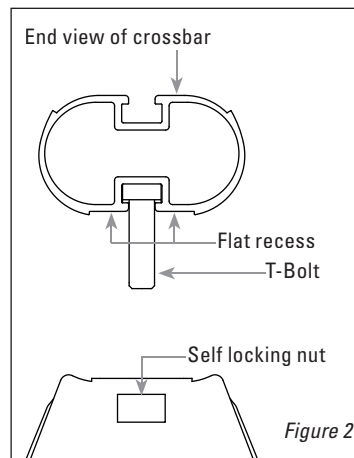

Figure 2

7. Place a complete assembly at the desired location on the van's roof, making sure that the Crossbars are parallel with the front of the van. Check that the Corner Brackets are the same distance from the driver and passenger doors.

- **Roof Installation A: Normal Installation**
- **Roof Installation B: Gutter Span Installation**

### Roof Installation A: Normal Installation

8. The lower edge of each Corner Bracket fits snugly into the top corner of the van's rain gutter. Place the J-Hooks with Neoprene Strips around the outside edge of rain gutter (see Fig 3A).

**CAUTION:** Re-torque all fasteners after first 100 miles to adjust for settling. Recheck all torques every 3000 miles. Prolonged driving, vibrations may cause the fasteners to loosen.

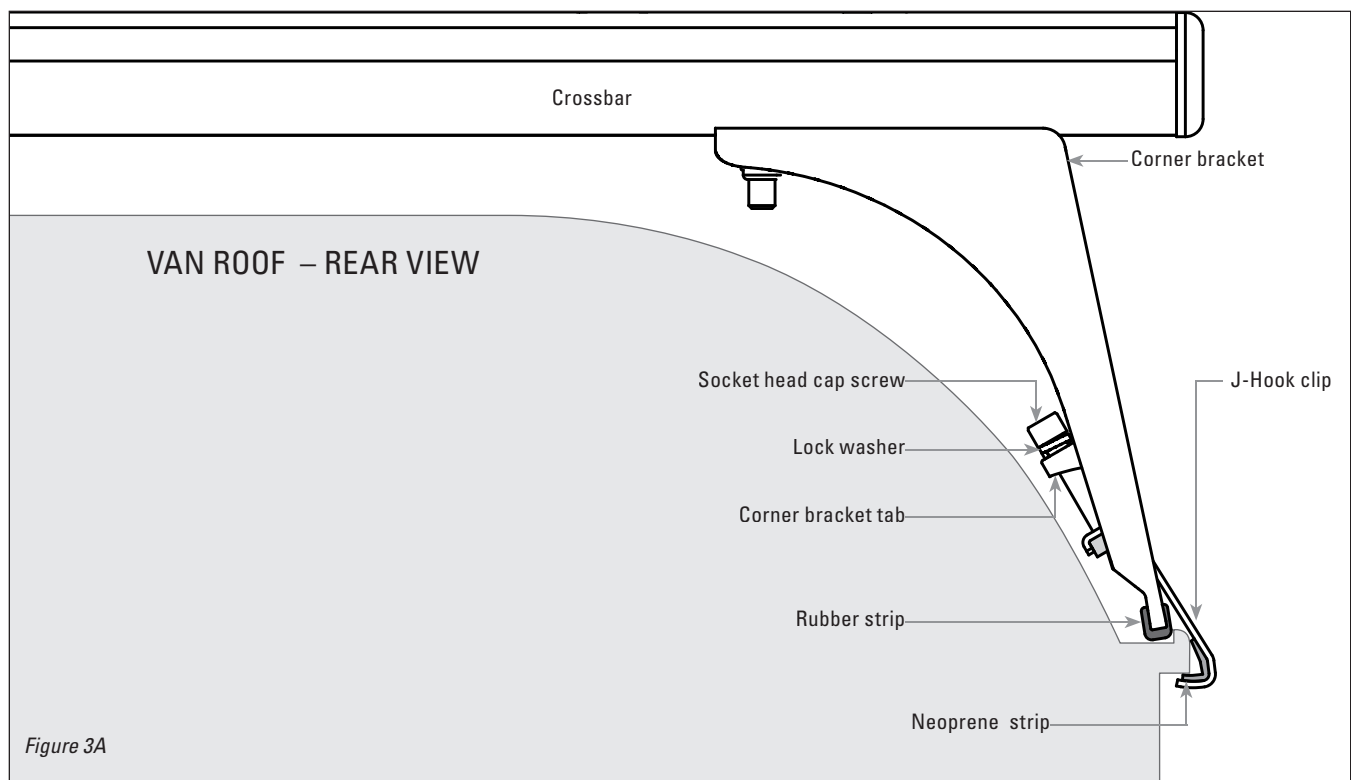

Figure 3A

- Center the Crossbars by measuring from the end of each Corner Bracket, to the Crossbar ends, left and right.
- Tighten the T-Bolts on the underside of the Crossbar to 240 in/lbs. (20 ft/lbs.) to secure the Corner Brackets to the Crossbar.
- Now tighten all Socket Head Cap Screws to 120 in/lbs. (10 ft/lbs.) with the supplied Allen Wrench.
- Reposition the Crossbar Tiedowns where desired. Now you're ready to go!

**Capacity** – The TracVan System is rated for a capacity of 500 lbs., evenly distributed over all racks, assuming normal driving conditions and loading.

Do not exceed the racks' rated capacity, as you could damage the van's rain gutter.

**Secure loads carefully and exercise caution at all times.**

- We recommend using transverse ratchet straps to securely tie down cargo.
- Run additional ratchet straps around the front & rear of loads, attaching them to the Crossbars to prevent any load shifting during acceleration and stopping.

## Roof Installation B: Gutter Span Installation

8. Slide 2 Gutter Spans under each Corner Bracket so that they line up under the slots as shown, with the "V" Groove facing up. The "Hook" of the Gutter span must engage the upper edge of the gutter, with the opposite end positioned in the middle of the gutter groove (see Fig 3B).

**CAUTION:** Re-torque all fasteners after first 100 miles to adjust for settling. Recheck all torques every 3000 miles. Prolonged driving, vibrations may cause the fasteners to loosen.

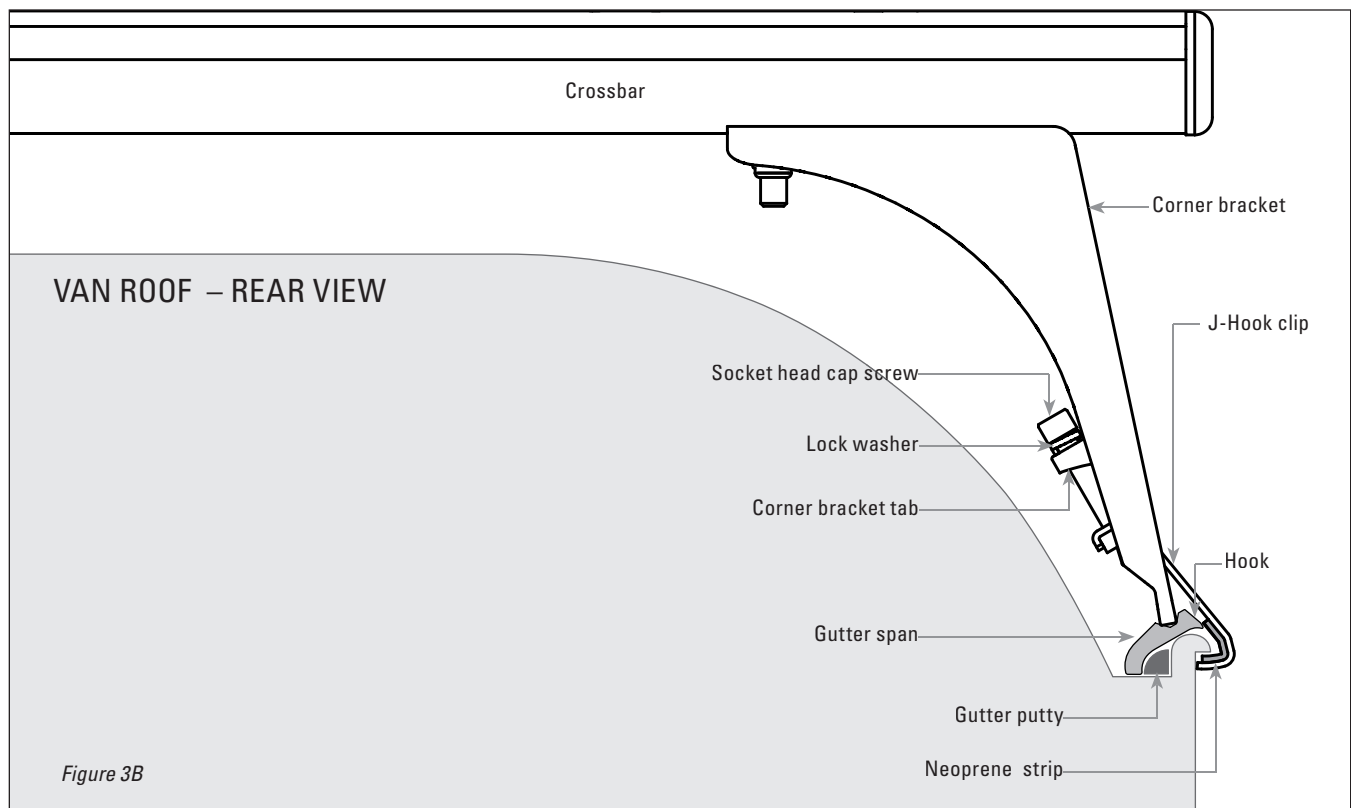

Figure 3B

9. The lower edge of each Corner Bracket fits snugly into the top of the Gutter Span. Place the J-Hooks around the outside edge of rain gutter (see Fig 3B).
10. Center the Crossbars by measuring from the end of each Corner Bracket, to the Crossbar ends, left and right.
11. Tighten the T-Bolts on the underside of the Crossbar to 240 in/lbs. (20 ft/lbs.) to secure the Corner Brackets to the Crossbar.
12. Now tighten all Socket Head Cap Screws to 120 in/lbs. (10 ft/lbs.) with the supplied Allen Wrench.
13. Reposition the Crossbar Tiedowns where desired.  
Now you're ready to go!

**Capacity** – The TracVan System is rated for a capacity of 500 lbs., evenly distributed over all racks, assuming normal driving conditions and loading.

Do not exceed the racks' rated capacity, as you could damage the van's rain gutter.

**Secure loads carefully and exercise caution at all times.**

- We recommend using transverse ratchet straps to securely tie down cargo.
- Run additional ratchet straps around the front & rear of loads, attaching them to the Crossbars to prevent any load shifting during acceleration and stopping.

## SHIM INSTALLATION

### Supplied as part of SKU 29056XT, Van Triple

The gutters on some Vans are curved, which makes installing three level crossbars a special challenge. To compensate for this curvature, you'll install our shims in the front and rear crossbar assemblies, raising them to the height of the middle rack.

1. Verify that you have received four Van Rack Shims.
2. Install the middle (third) crossbar assembly roughly in center of van roof per Van Rack Installation Instructions.
3. Loosely assemble the front and rear crossbar assemblies, placing the shims between the corner brackets and the crossbar (*Fig. 4*).
4. Install the front crossbar assembly in desired location near front of van roof, and tighten all fasteners in accordance with Van Rack Installation Instructions.
5. Position the rear crossbar assembly on rear of van roof, engaging lower edge of corner brackets in rain gutters.
6. Place a straight-edge (a ladder or straight piece of lumber will do) atop crossbars (*Fig. 5*) to check that the racks are all in line. As necessary, slide the rear crossbar assembly to the front or rear until the straight-edge rests flatly and evenly on all three crossbars. Complete installation to rear crossbar assembly in accordance with Van Rack Installation Instructions.
7. Check all fasteners for proper torque.

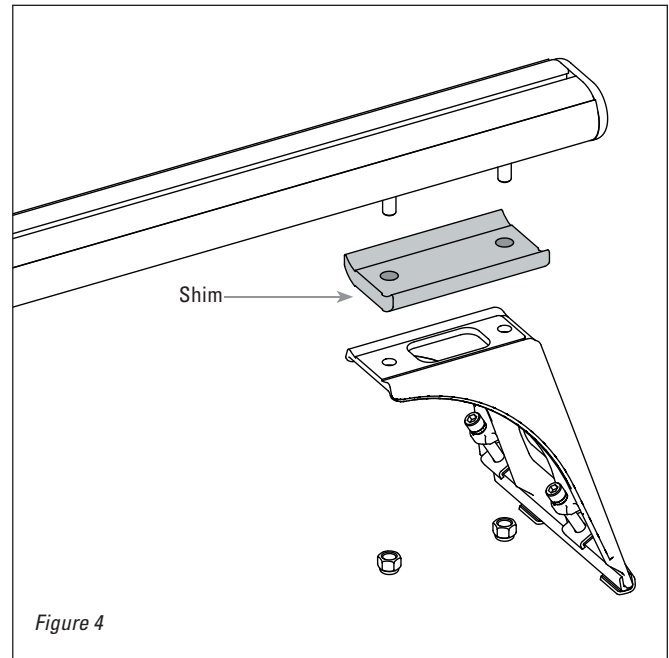

Figure 4

**Caution:** Recheck the bolt torques every 3000 miles.

With prolonged driving, vibrations may cause the fasteners to loosen.

Capacity: The van rack is rated for a capacity of 500 lbs., evenly distributed, assuming normal driving conditions and loading. Please secure loads carefully, and exercise caution at all times!

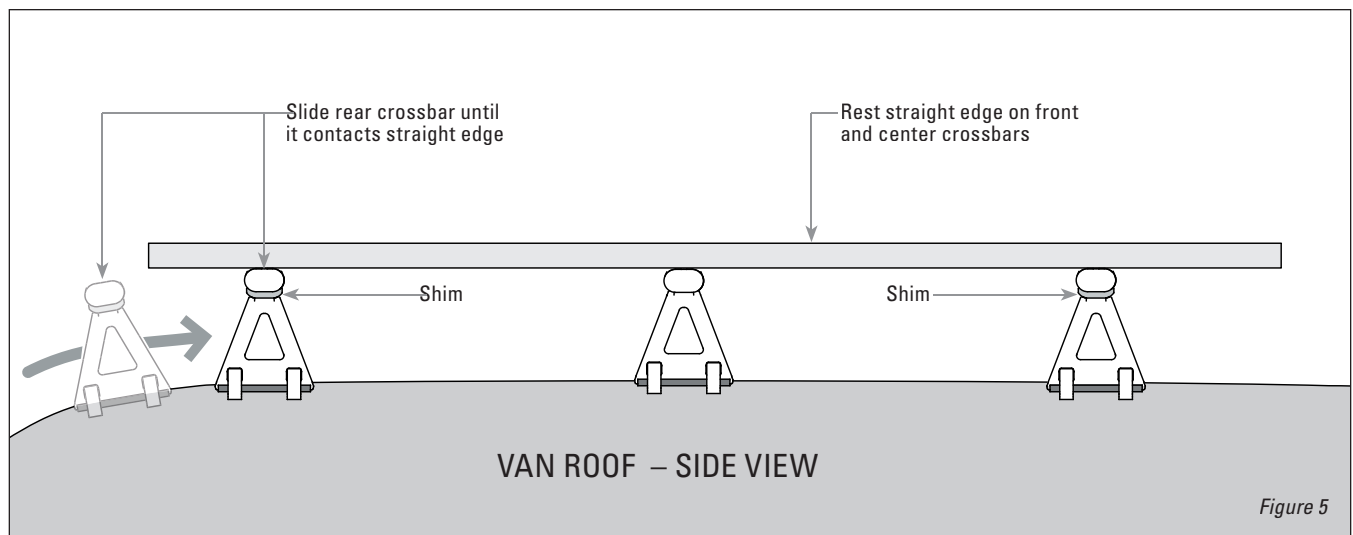

Figure 5

## THULE RACK GUIDELINES

When using Thule Load carriers and accessories, the user must understand the precautions. The points listed below will assist you in using the rack system and will encourage safety.

- For quality fits and safety, use only the recommended rack or accessory as stated in Thule's current Fit Guide. Do not assume a rack will fit, always check the current Fit Guide when obtaining a new vehicle.
- The maximum load specified in the assembly instructions is not to be exceeded. However, this limit is always subordinate to the maximum load recommended by the manufacturer of the car itself. It is always the lower maximum recommended load that applies. **Max roof load = load carrier weight + any fitted carrier accessories + the weight of the load itself.**
- Always make sure all doors are open when mounting a roof rack system. Make sure all knobs, bolts, screws, straps, and locks are firmly attached, tightened and locked before every trip. Knobs, bolts, screws, straps and locks must be periodically inspected for signs of wear, corrosion, and fatigue. Check your load at stops during the trip to ensure continued fastening security.
- Check local and state laws governing projection of objects beyond the perimeter of a vehicle. Be aware of the width and height of your cargo since low clearance branches, bridges, and parking garages can affect the load. All cargo will affect the vehicle's driving behavior. Never drive with any lock, knob or rack in an open or unlocked position. All long loads such as, but not limited to, sailboards, surfboards, kayaks, canoes, and lumber must be tied down front and rear to the bumpers or tow hooks of the vehicle.
- Remove your Thule rack and accessories when they are not in use and before entering automatic car washes.
- All locks must be turned and moved periodically to ensure smooth operation. Use graphite or dry lubricant to help this. Thule locks are designed to deter vandalism and theft but should not be considered theft proof. Remove valuable gear if your vehicle is unattended for an extended period. Place at least one key in the glove compartment.
- For safety to your vehicle and rack system, obey all posted speed limits and traffic cautions. Adapt your speed to the conditions of the road and the load being carried.
- Do not use Thule load carriers and accessories for purposes other than those for which they were designed. Do not exceed their carrying capacity. Failure to follow these guidelines or the product's instructions will void the warranty.
- All loads must be secured using the provided straps.
- Consult with your Thule dealer if you have any questions regarding the operations and limits of Thule products. Review all instructions and warranty information carefully.
- Not for use on trailers or towed vehicles.
- Not for offroad use.
- Keep bicycle tires away from hot exhaust.