

JK Rear Speedbump Kit with Extended Microcellular Foam for 2.5" Lifts



Important Notes:

Prior to beginning this or any installation read these instructions to familiarize yourself with the required steps and evaluate if you are experienced and capable to personally perform these modifications.

Refer to the parts list to ensure that all necessary components and hardware has been included. If any parts are missing please contact your local retailer for assistance.

Kit Contents

Item ID	Item Name	Quantity
600193	Instructions	1
467265	Rear Upper SpeedBump Cup Extension	2
5035	Hardware Bag	1
954600	3/4" Rear Lower Bumpstop Pad	2
992014	Extended SpeedBump Microcellular Foam	2

Tools Needed

- Allen Wrench - 3/16"
- End Wrench - 1/2"
- Hammer
- Ratchet - 1/2"
- 1/2" Drive Socket - 18mm
- 1/2" Extension - 12" long

TERRAFLEX

PRODUCT INSTALLATION GUIDE

1. Begin with removing the factory bumpstop from the frame mount by simply pulling in a downward position with a slight twisting motion.
2. After removal, the upper SpeedBump cup snaps onto the frame bumpstop bell.

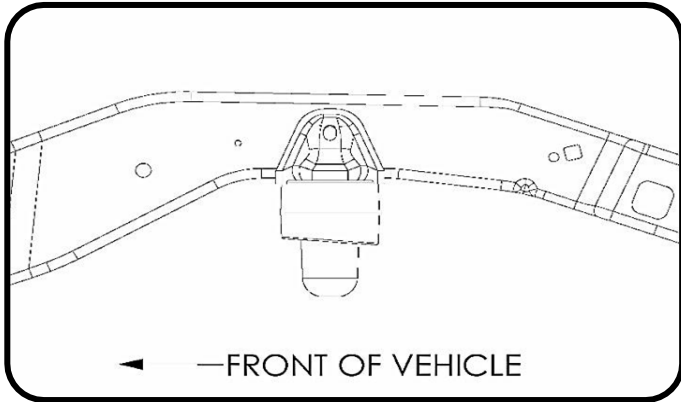

3. Position the SpeedBump cup with the longer side of the slope, or the large end of the taper facing the rear. The notched cuts on the top of the cup index around the factory bumpstop frame bracket.

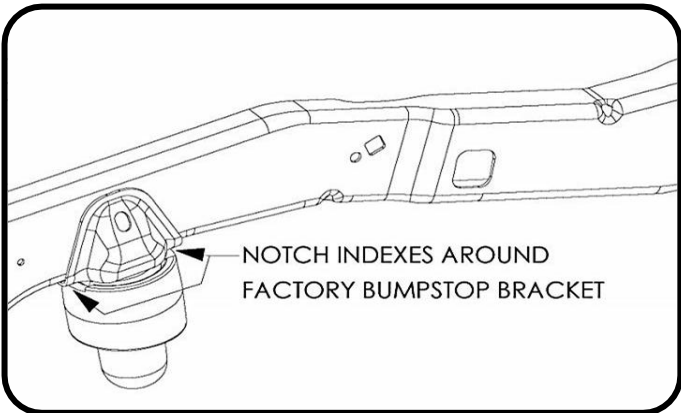

4. On most vehicles the cup will snap into place quite easily. A few taps with a hammer will aid with installation on those with slightly larger bumpstop bell housings.
5. Next, twist and push the new SpeedBump bumpstop into position. Some silicone spray lubricant will help it pop into place.



Note:

The next 3 steps are very important to follow to avoid and prevent any damage to your vehicle.

6. Remove the bottom bolt from the rear swaybar link on the passenger and driver side. Cycle the swaybar through it's range of motion and check for clearance issues between the swaybar links and your new SpeedBump kit.
7. It may be necessary on some Jeeps to file the SpeedBump cup for clearance. You can accomplish this with a flat hand file.



8. Reinstall swaybar links.
9. Locate the rear lower bumpstop pad (992014) and install the lower bumpstop pad with the extended end facing forward. Torque the 5/16"-18 socket cap screw to 200 In. Lbs (22 N·m).

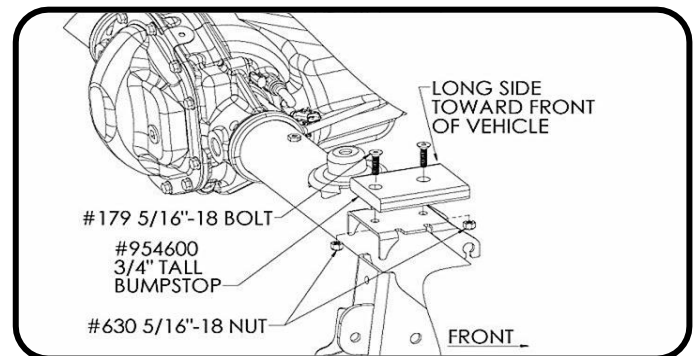

10. Your rear SpeedBump kit install is now complete.
11. Check and re-torque all suspension components and bolts every 3,000 miles, and after driving off road.



PRODUCT INFORMATION

MAINTENANCE INFORMATION:

It is the buyer's responsibility to have all suspension, drivetrain, steering, and other components checked for proper tightness and torque after the first 100 miles and every 3000 miles after that.

NOTICE TO INSTALLER:

The enclosed "Warning to Driver" sticker must be installed in the vehicle in driver's view. This sticker is to act as a constant safety reminder when operating the vehicle. It is your responsibility as the equipment installer to install the provided sticker and to forward the product instructions to the vehicle's owner for review. If a "Warning to Driver" sticker or product installation guide were not included in the kit, FREE replacement stickers and instructions are available by request. It is the installer's duty to ensure a safe and controllable vehicle after the modifications have been performed.

WARNING:

Neither the seller nor the manufacturer will be liable for any loss, damage, or injury directly or indirectly arising from the use of or inability to determine the use of these products. Before using, the user shall determine the suitability of the products for its intended use, and the user shall assume all responsibility and risk in connection therewith.

WARNING TO DRIVER:

This vehicle has been modified to enhance off road performance and has unique handling characteristics. Use in harsh environments can cause extreme stress on the components. Vehicle should be inspected after being off road to make sure that all the components are in working order and safe to travel on the highway. All fasteners should be checked so that they are at the correct torque specifications as the vibration and stresses from off-roading may cause critical fasteners to work loose. Extra care should be taken to inspect the critical components, steering, and brake systems. During each oil change components such as arms, tie rod ends, etc. should be greased and checked for excessive wear. Any worn components should be replaced. When returning to the pavement always set or restore tire air pressure to the factory recommendation and connect or engage any disabled sway bar mechanisms. Because of the higher center of gravity and larger tires, this vehicle handles and reacts differently than many passenger cars, both on and off road. You must drive it safely! Extreme care should be taken to prevent vehicle rollover or loss of control, which can result in serious injury or death. Avoid sudden sharp turns or abrupt maneuvers. Generally, braking performance and capabilities are decreased when significantly larger/heavier tires are used, especially when used in combination with transfer case low-range reduction kits. Take this into consideration while driving. Do not add, alter or fabricate any factory or aftermarket parts to increase vehicle height over the intended height of the TeraFlex product purchased. Mixing component brand is not recommended. TeraFlex Inc. will not be responsible for any altered product or any improper installation or use of our products. We will be happy to answer any questions concerning the design, function, and correct use of our products. It is ultimately the buyer's responsibility to have all bolts/nuts checked for tightness after the first 100 miles and then every 3000 miles. Wheel alignment, steering system, suspension and drive line systems must be inspected by a qualified professional mechanic at least every 3000 miles.

TERAFLEX PRODUCT WARRANTY:

Tera Manufacturing warrants TeraFlex Suspension products to the original retail purchaser to be free of defects in material and workmanship for as long as the original purchaser owns the vehicle on which products were originally installed. Failure to complete regular maintenance (grease every 3000 miles) on TeraFlex FlexArms will void this warranty. All other conditions of the standard TeraFlex product warranty apply.

All TeraLow products are covered by TeraFlex's two (2) year warranty to be free of defects in material and workmanship for two years from date purchased.

Tera axles are covered by a 12-month warranty to be free of defects in materials and workmanship. This warranty does not cover or include product finish, improperly installed or applied products, improperly maintained products, products or components used for racing or competition or damage due to abuse or neglect, products that fail due to the use of larger tire and wheel combinations.

All returns must be accompanied by an original invoice. It is the customer's responsibility to remove the product from the vehicle. Shipping charges are the responsibility of the customer. Tera Manufacturing will pay the return freight if the product meets the terms of warranty.

This warranty is for the replacement or repair of defective TeraFlex products only and does not include freight charges, labor charges for removal of or installation of TeraFlex or related products or components, costs incurred due to down time of the vehicle, or lost profits due to vehicle down time.

A returned goods authorization number (RGA#) must accompany any returned products.