

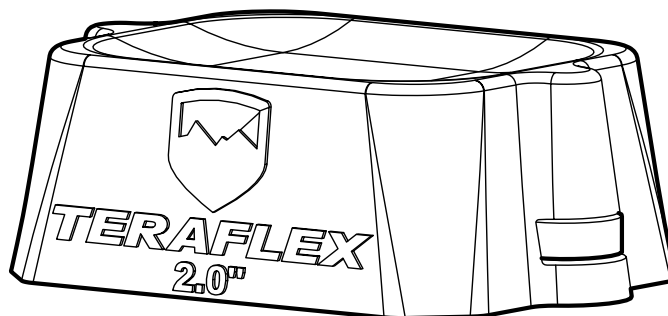

JL 2" Bumpstop Kit

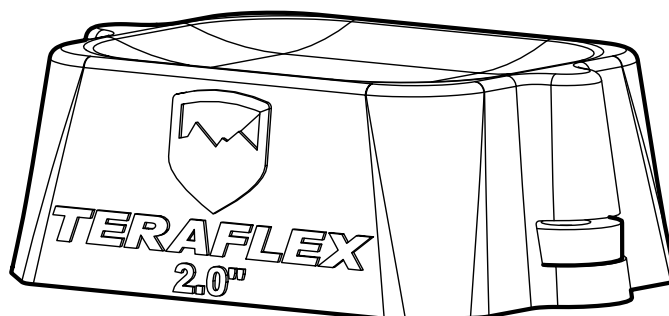
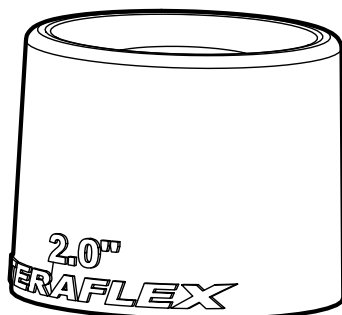

Important Notes:

Prior to beginning this install, or any installation, read the instructions thoroughly to familiarize yourself with the required steps. Evaluate if you are experienced and capable to personally perform these modifications. A factory service manual should be used in conjunction with these installation instructions.

This product will change the highway handling characteristics of your vehicle, exercise caution. After altering the suspension it is always advisable to have an alignment done by a competent 4 wheel drive shop or by an alignment shop that is experienced with lifted 4 wheel drive vehicles.

Refer to the parts list to ensure that all necessary components and hardware has been included.

When reinstalling OEM hardware, refer to the torque specs given in the Factory Service Manual.

Tools Needed:

- Metric Sockets and Open End Wrenches
- Torque Wrench
- Factory Service Manual
- General Mechanics Tools

Maintenance Note:

After the first 300 miles and every 3,000 miles after that, re-torque all the suspension components and bolts.

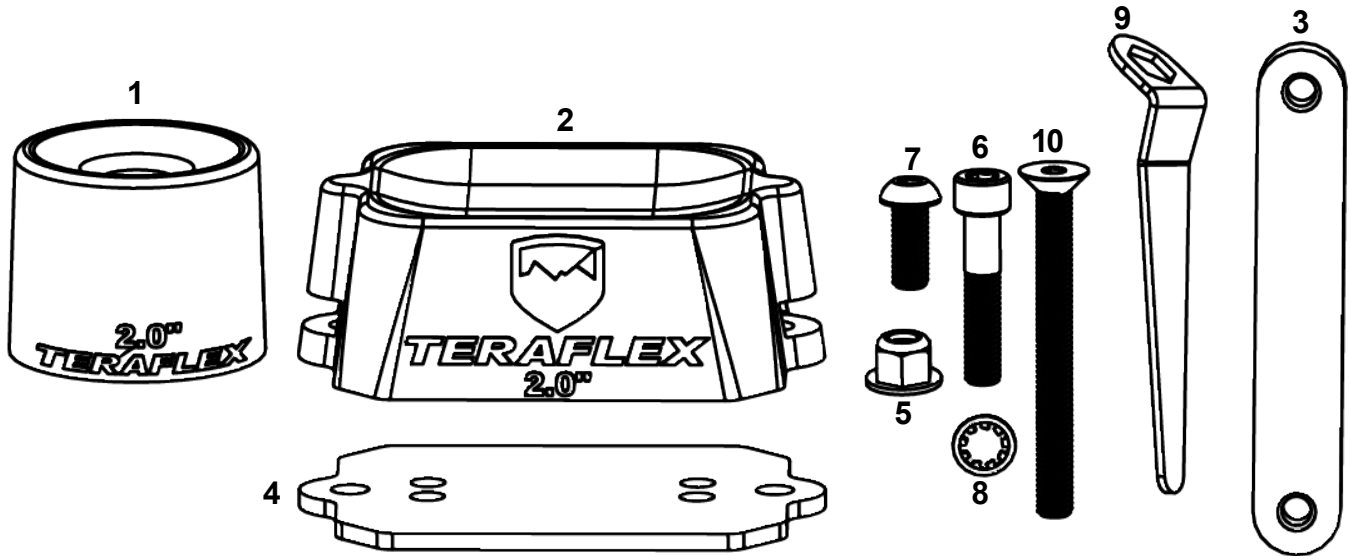

Item #	Part No.	Description	QTY
1	12-01-109-200	Bumpstop, Top Spacer, Front, Jeep JL Wrangler, 2.00" Lift Height	2
2	12-01-209-200	Bumpstop, Top Spacer, Rear, Jeep JL Wrangler, 2.00" Long	2
3	12-02-209-001	Bumpstop, Bracket, Rear, Jeep JL Wrangler, Mounting Strap,M10 X 1.5	2
4	12-02-209-002	Bumpstop, Bracket, Rear, Jeep JL Wrangler, Mounting Plate	2
	5087	Rear Hardware Pack	
5	23-07-03-001	Mounting Hardware,Flanged Fuji Nut, M10 x 1.5 / Yellow	4
6	45-03-003-001	Hardware, Socket Cap Screw, Alloy Steel, M10 x 1.5 x 50mm	4
7	45-05-003-003	Hardware, Button Socket Cap Screw, Alloy Steel, M10 x 1.5 x 25mm	4
8	45-12-002-001	Hardware, Internal Tooth Lock Washer, Alloy Steel, Zinc, M10	4
	5088	Front Hardware Pack	
5	23-07-03-001	Mounting Hardware, Flanged Fuji Nut, M10 x 1.5 / Yellow	2
9	600271	JK Rear Lower Spring Retainer Nut Wrench Tool	1
10	45-04-003-001	Hardware, Flat Socket Cap Screw , Alloy Steel, M10 X 1.5 X 100mm	2

FRONT INSTALLATION LIFT AND SUPPORT AT FRAME

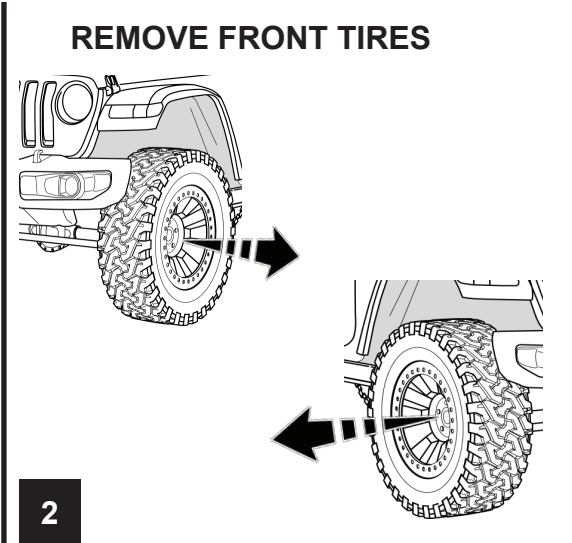
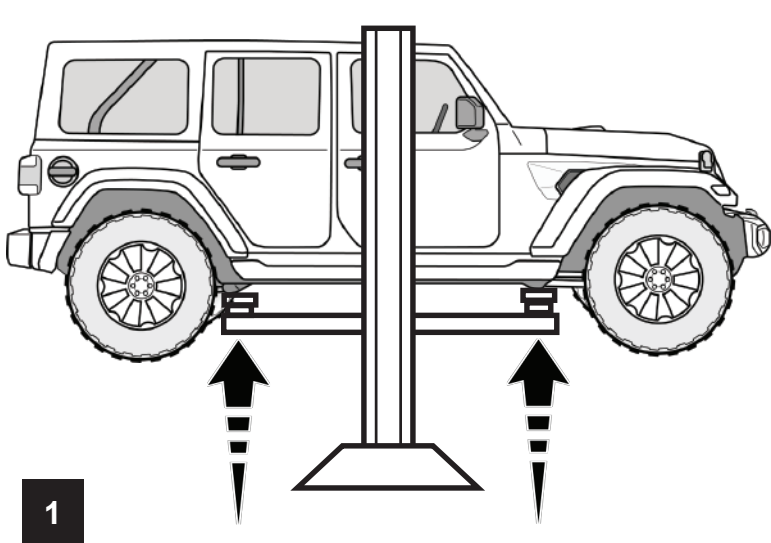
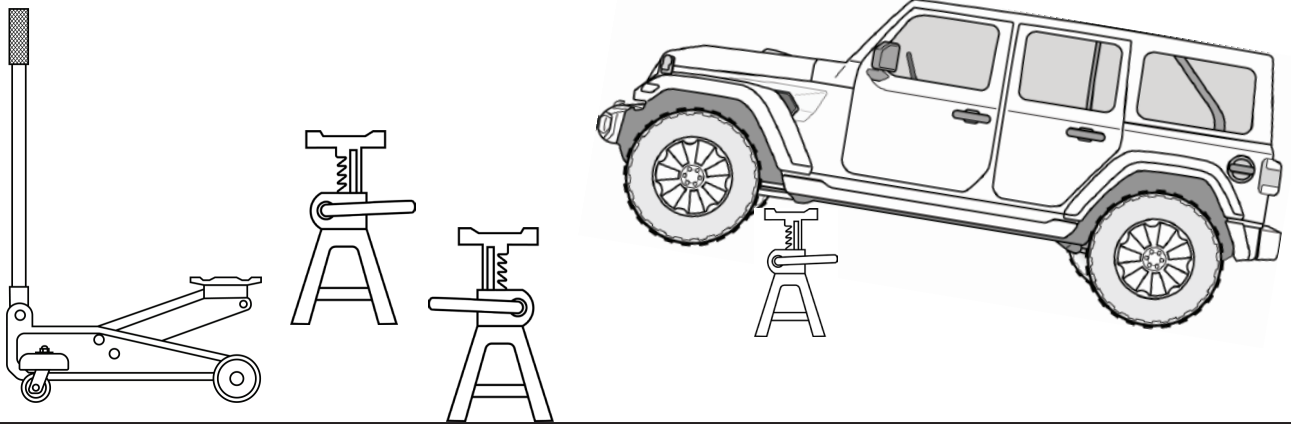

SUPPORT FRONT AXLE

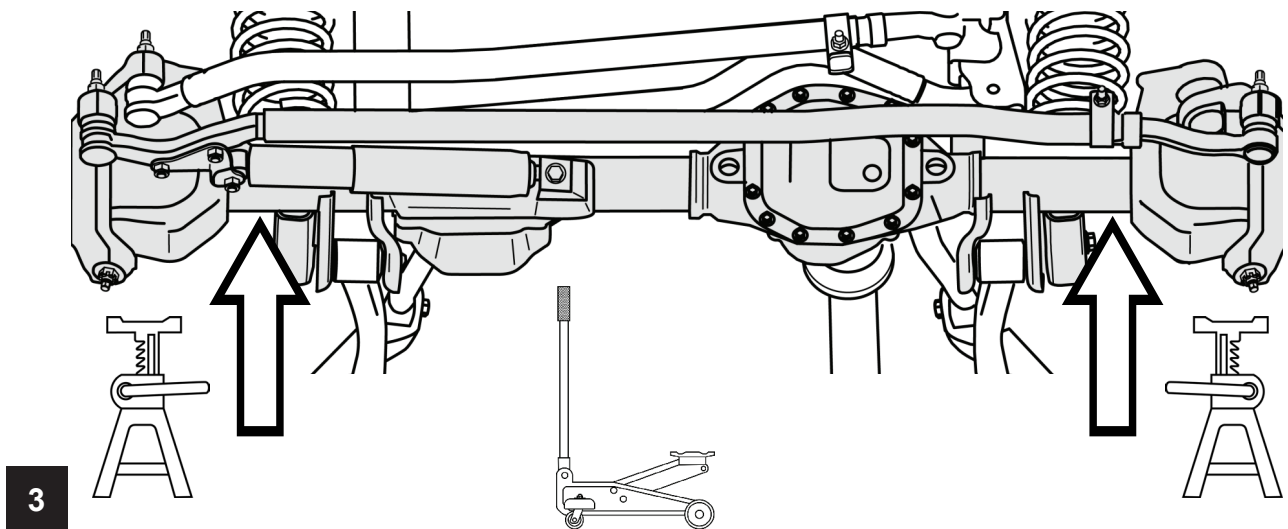

REMOVE SWAY BAR LINKS & TRACK BAR BOLTS AT THE AXLE

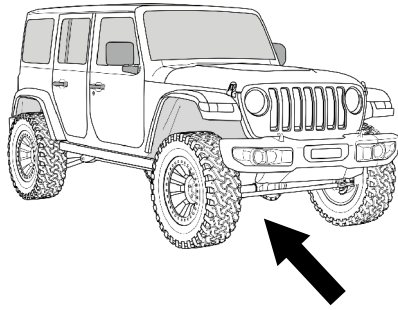

BOLT
18mm

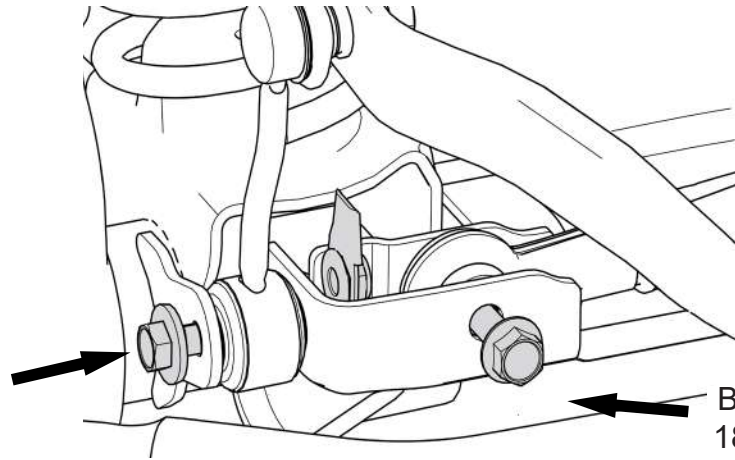

BOLT
18mm

4

REMOVE BRAKE LINE BRACKETS FROM LOWER CONTROL ARMS

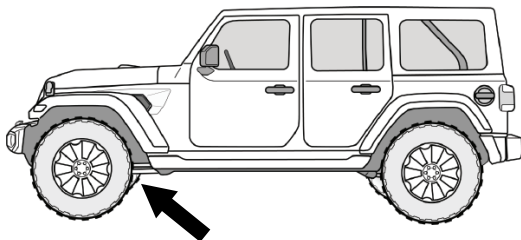
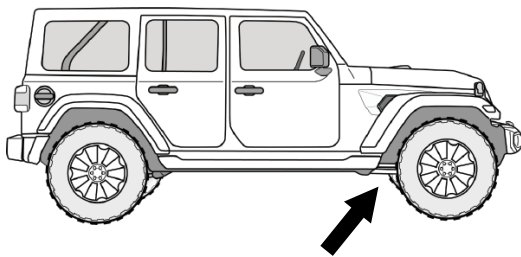

2X

5

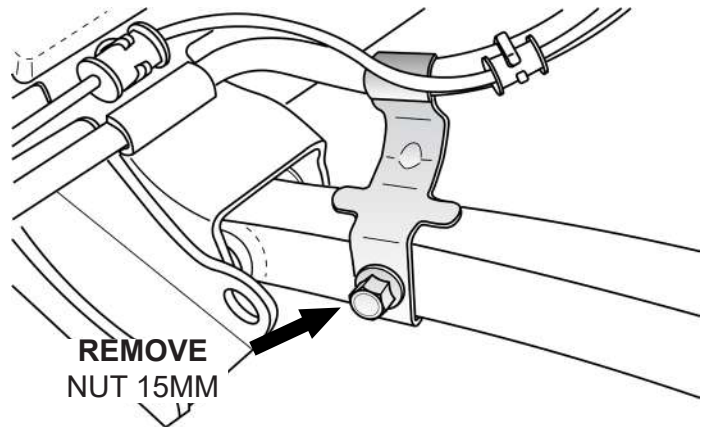

REMOVE
NUT 15MM

DISCONNECT ACTUATORS & VENT HOSE AT THE FRONT AXLE

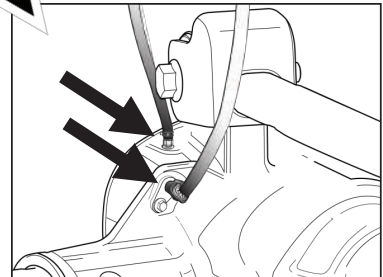
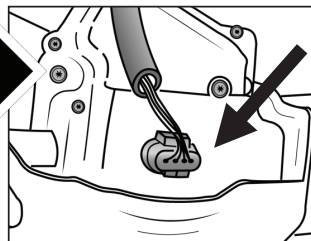
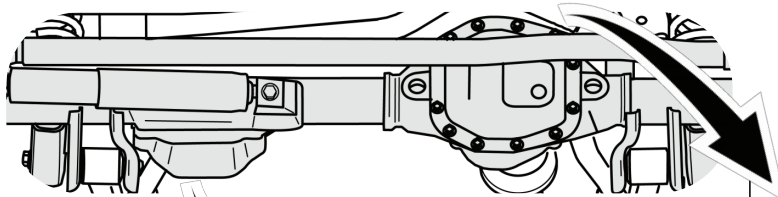

6

**LOOSEN FRONT CONTROL ARM BOLTS
DO NOT REMOVE THE CONTROL ARM BOLTS**

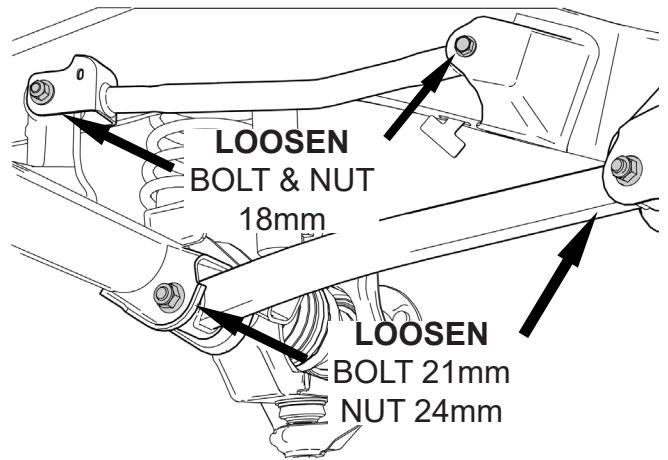
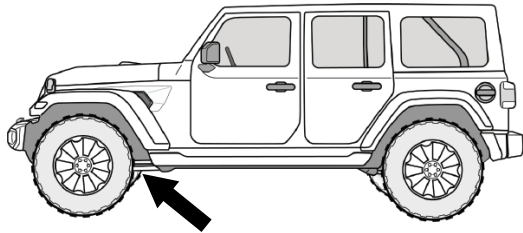
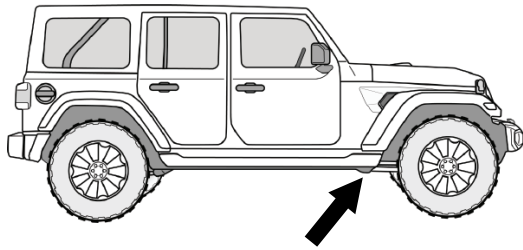

2X

7

REMOVE SHOCKS AT THE AXLE

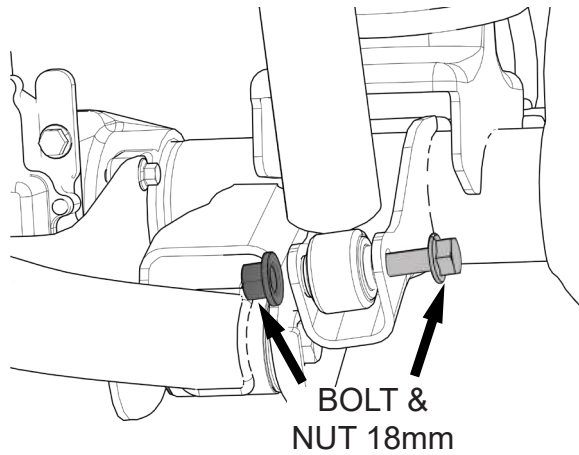

2X

8

LOWER AXLE & REMOVE FRONT SPRINGS

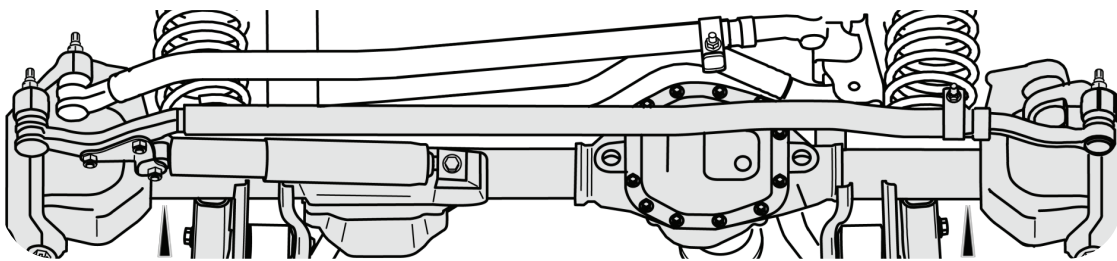

**NOTE: REMOVE ANY
PLASTIC RETAINERS
FROM WIRING OR
HOSES AS NEEDED.**

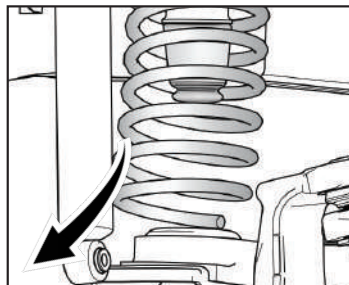

2X

9

INSTALL BUMPSTOP INTO FRONT SPRING

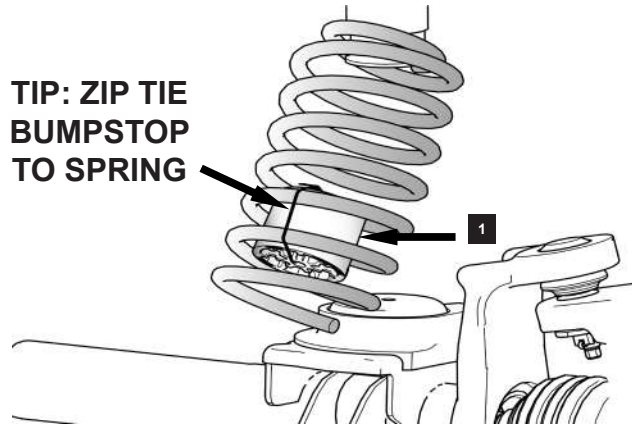

2X

10

NOTE: REFER TO PAGE 9 FOR BUMPSTOP SPACER GUIDE

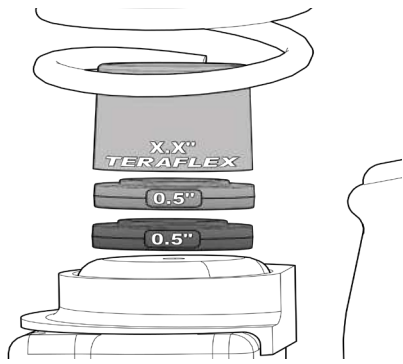

2X

11

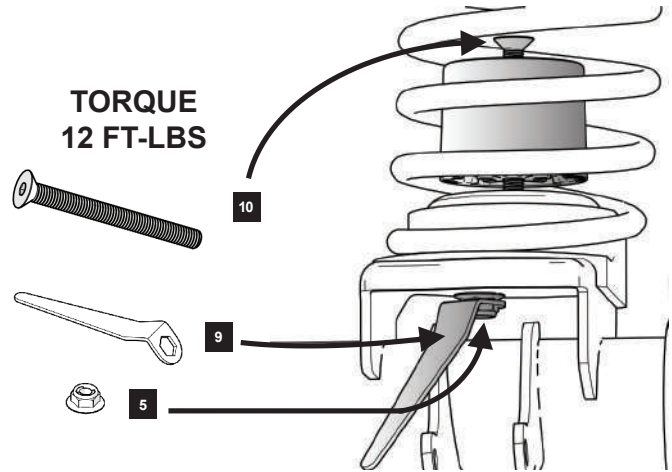

TORQUE
12 FT-LBS

10

9

5

FULLY SEAT THE SPRINGS INTO THE LOWER SPRING ISOLATOR

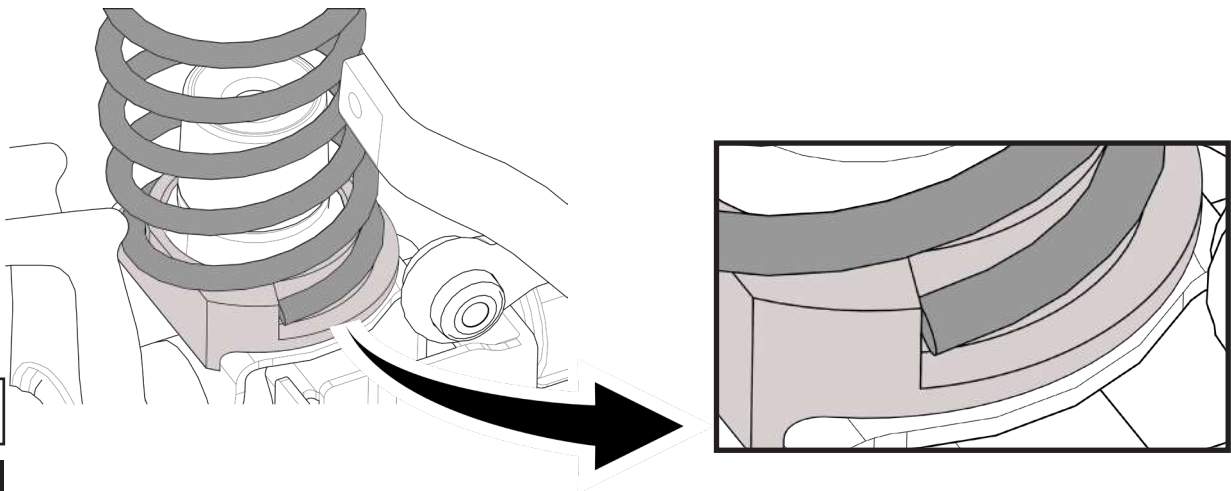

2X

12

RAISE AXLE & REINSTALL SHOCKS

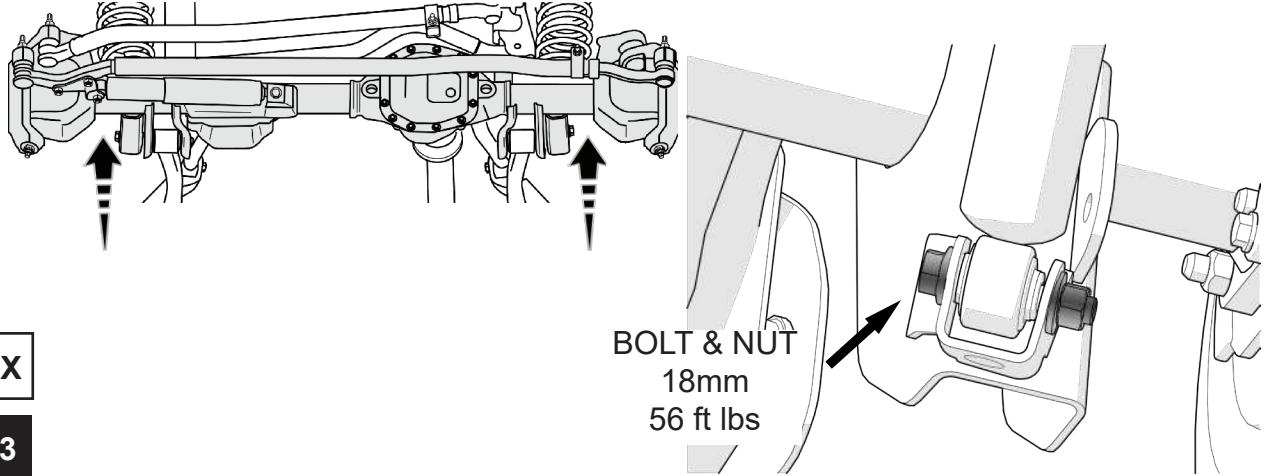

2X

13

REINSTALL SWAY BAR LINK AT AXLE

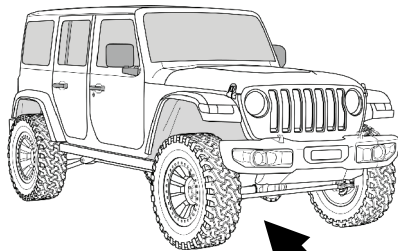

BOLT 18mm
59 ft lbs

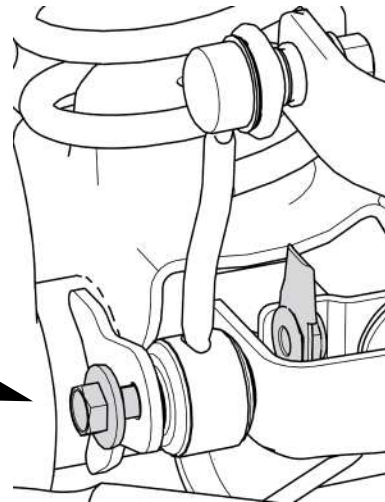

2X

14

**NOTE: IF ONLY FRONT OF JEEP WAS LIFTED, REINSTALL TIRES AND LOWER JEEP BACK TO THE GROUND BEFORE LIFTING THE REAR
REINSTALL ANY REMAINING CONNECTORS**

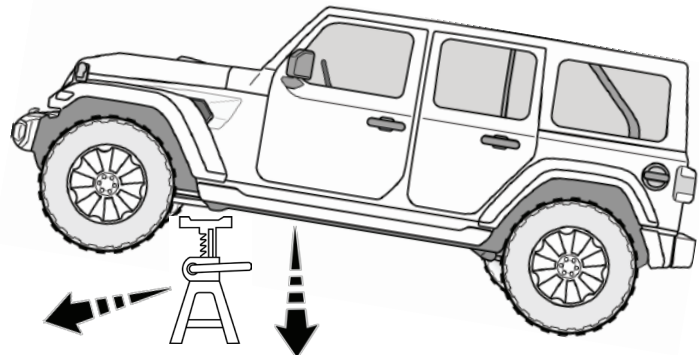
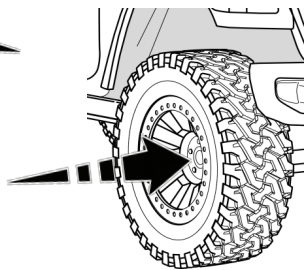
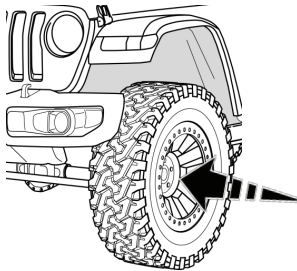

15

REAR INSTALL

NOTE: REAR BUMPSTOPS CAN BE INSTALLED WITHOUT RAISING THE JEEP.

2X

16

INSTALL REAR BUMPSTOP MOUNTING PLATE TO THE AXLE WITH SUPPLIED HARDWARE.

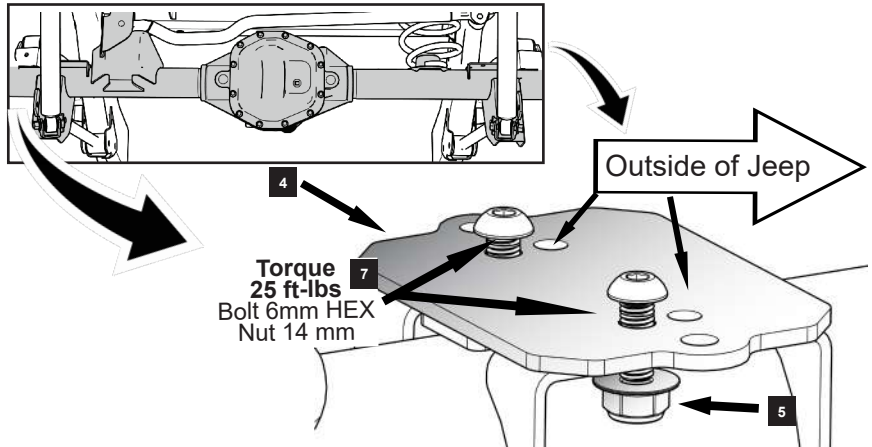

NOTE: INSTALL ADDITIONAL SPACERS IF REQUIRED. REFER TO PAGE 9 FOR BUMPSTOP GUIDE.

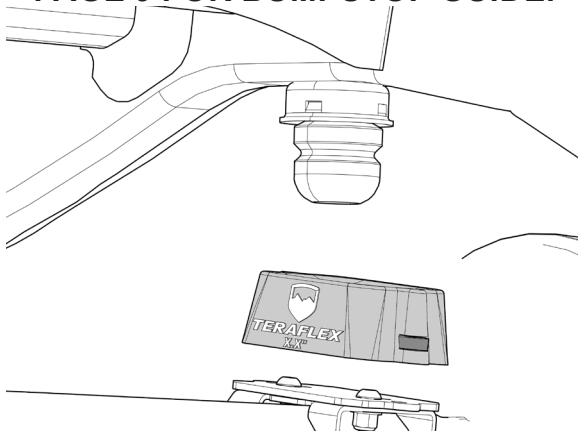

2X

17

INSTALL THE MOUNTING STRAP INTO THE BUMPSTOP.

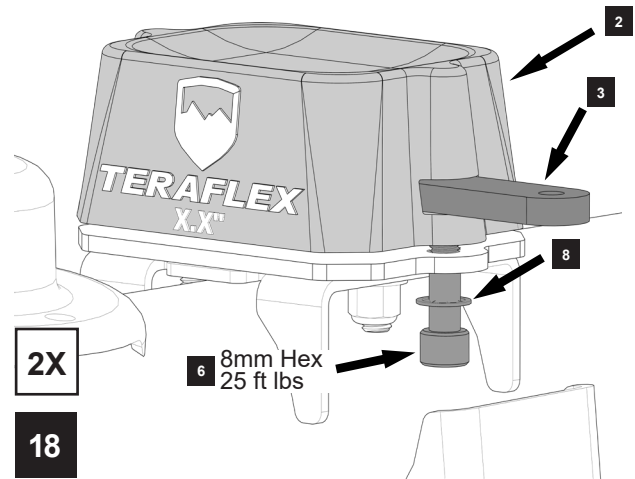

2X

18

**REINSTALL FRONT TRACK BAR. TORQUE TO FACTORY SPECS.
TORQUE FRONT CONTROL ARMS TO FACTORY SPECS.**

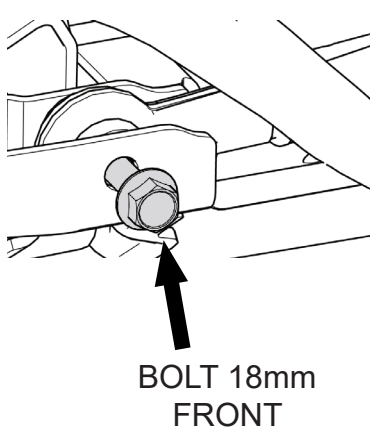

19

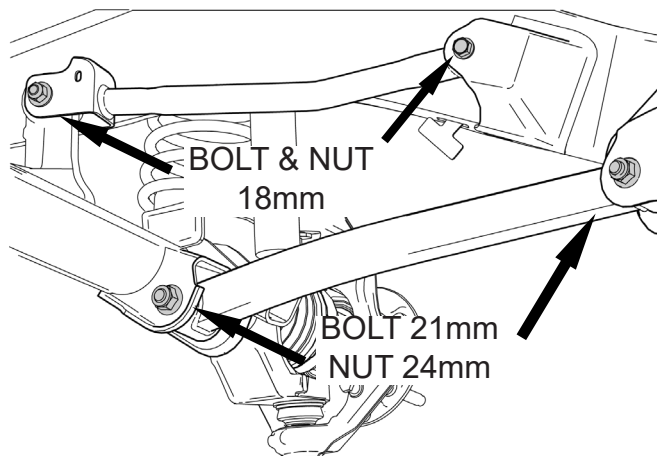

JL TIRE CLEARANCE GUIDE

By limiting suspension up travel, TeraFlex Bump Stops allow the use of larger tires while keeping the factory fenders.

JL Rubicon models feature high-clearance fenders that allow for more up travel, while the lower-clearance fenders on JL Sport and Sahara restricts tire size due to fender rubbing.

In order to address these fender differences, TeraFlex designed a proprietary modular bump stop system, which can be adapted to fit several different lift height and tire size configurations.

In addition to the main 2" bump stop spacers, this system includes multiple 0.5" interlocking spacers that can be added to fine tune bump stop height to limit suspension up travel.

JL RUBICON with Factory Flares:

Note: Not all Tires Measure the Same

- 33" - No Bump Stops
- 35" - 2" Front & 2" Rear Bump Stops

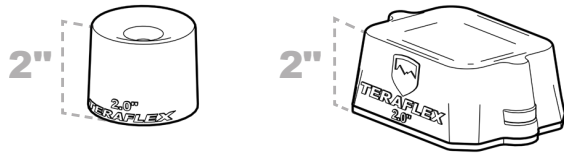

- 37" - 2.5" Front & 3" Rear Bump Stops

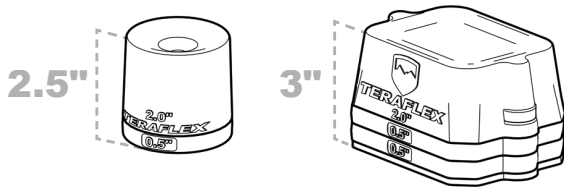

JL SPORT with Factory Flares:

Note: Not all Tires Measure the Same

- 33" - No Bump Stops
- 35" - 3" Front & 2.5" Rear Bump Stops

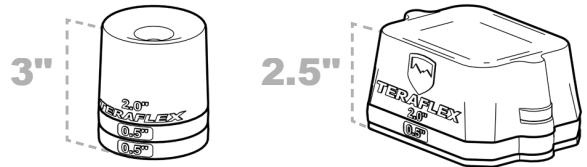

- 37" - 3.5" Front & 4" Rear Bump Stops

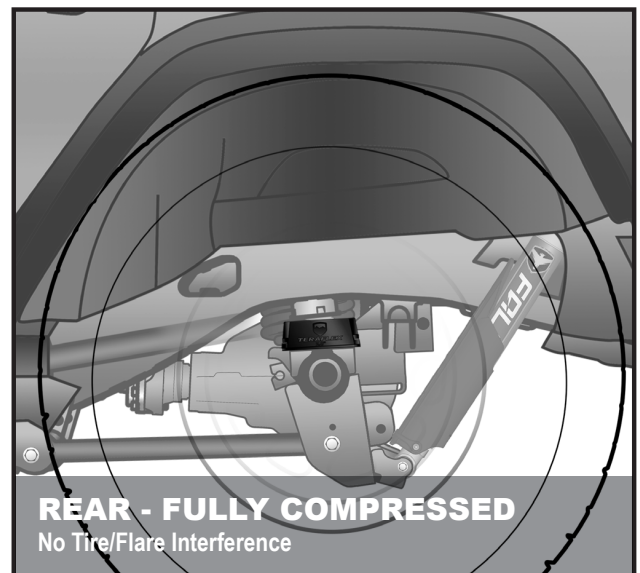
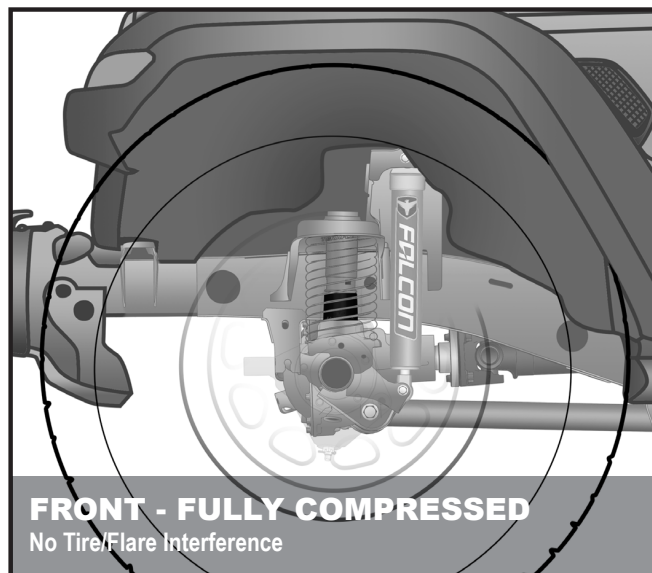
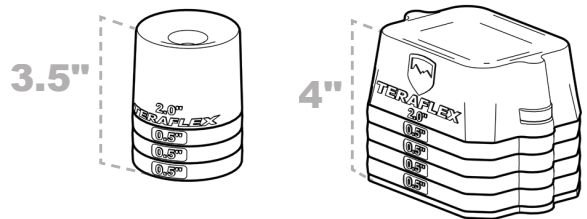

TERAFLEX

PRODUCT INFORMATION

MAINTENANCE INFORMATION:

It is the buyer's responsibility to have all suspension, drivetrain, steering, and other components checked for proper tightness and torque after the first 100 miles and every 3000 miles after that.

NOTICE TO INSTALLER:

The enclosed "Warning to Driver" sticker must be installed in the vehicle in driver's view. This sticker is to act as a constant safety reminder when operating the vehicle. It is your responsibility as the equipment installer to install the provided sticker and to forward the product instructions to the vehicle's owner for review. If a "Warning to Driver" sticker or product installation guide were not included in the kit, FREE replacement stickers and instructions are available by request. It is the installer's duty to ensure a safe and controllable vehicle after the modifications have been performed.

WARNING:

Neither the seller nor the manufacturer will be liable for any loss, damage, or injury directly or indirectly arising from the use of or inability to determine the use of these products. Before using, the user shall determine the suitability of the products for its intended use, and the user shall assume all responsibility and risk in connection therewith.

WARNING TO DRIVER:

This vehicle has been modified to enhance off road performance and has unique handling characteristics. Use in harsh environments can cause extreme stress on the components. Vehicle should be inspected after being off road to make sure that all the components are in working order and safe to travel on the highway. All fasteners should be checked so that they are at the correct torque specifications as the vibration and stresses from off roading may cause critical fasteners to work loose. Extra care should be taken to inspect the critical components, steering, and brake systems. During each oil change components such as arms, tie rod ends, etc should be greased and checked for excessive wear. Any worn components should be replaced. When returning to the pavement always set or restore tire air pressure to the factory recommendation and connect or engage any disabled sway bar mechanisms. Because of the higher center of gravity and larger tires, this vehicle handles and reacts differently than many passenger cars, both on and off road. You must drive it safely! Extreme care should be taken to prevent vehicle rollover or loss of control, which can result in serious injury or death. Avoid sudden sharp turns or abrupt maneuvers. Generally, braking performance and capabilities are decreased when significantly larger/heavier tires are used, especially when used in combination with transfer case low-range reduction kits. Take this into consideration while driving. Do not add, alter or fabricate any factory or aftermarket parts to increase vehicle height over the intended height of the TeraFlex product purchased. Mixing component brand is not recommended. TeraFlex Inc. will not be responsible for any altered product or any improper installation or use of our products. We will be happy to answer any questions concerning the design, function, and correct use of our products. It is ultimately the buyer's responsibility to have all bolts/nuts checked for tightness after the first 100 miles and then every 3000 miles. Wheel alignment, steering system, suspension and drive line systems must be inspected by a qualified professional mechanic at least every 3000 miles.