

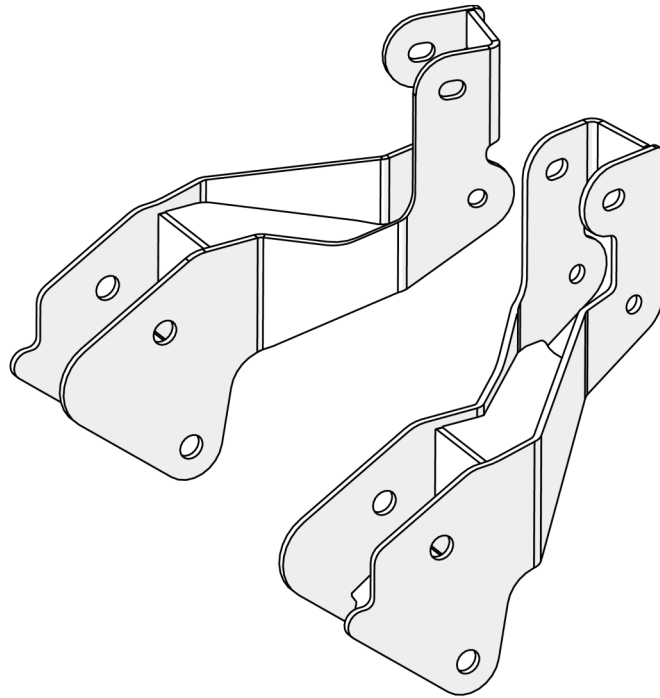

JL Front Drop Bracket Kit

Instructions

Kit #1938125 - Drop Bracket Kit, Jeep JL Wrangler, Front Passenger and Driver



IMPORTANT NOTES:

Prior to beginning this install, or any installation, *read the instructions thoroughly* to familiarize yourself with the required steps. Evaluate if you are experienced and capable to personally perform these modifications. A factory service manual should be used in conjunction with these installation instructions.

This product will change the highway handling characteristics of your vehicle, exercise caution. After altering the suspension it is always advisable to have an alignment done by a competent 4 wheel drive shop or by an alignment shop that is experienced with lifted 4 wheel drive vehicles.

Refer to the parts list to ensure that all necessary components and hardware has been included.

Refer to the factory service manual for the torque specs of the originally equipped hardware.

TOOLS NEEDED:

- This installation guide
- Basic mechanics tool set
- Factory Service Manual

MAINTENANCE INFORMATION:

It is the buyer's responsibility to have all suspension, drivetrain, steering, and other components checked for proper tightness and torque after the first 300 miles and every 3000 miles after that.

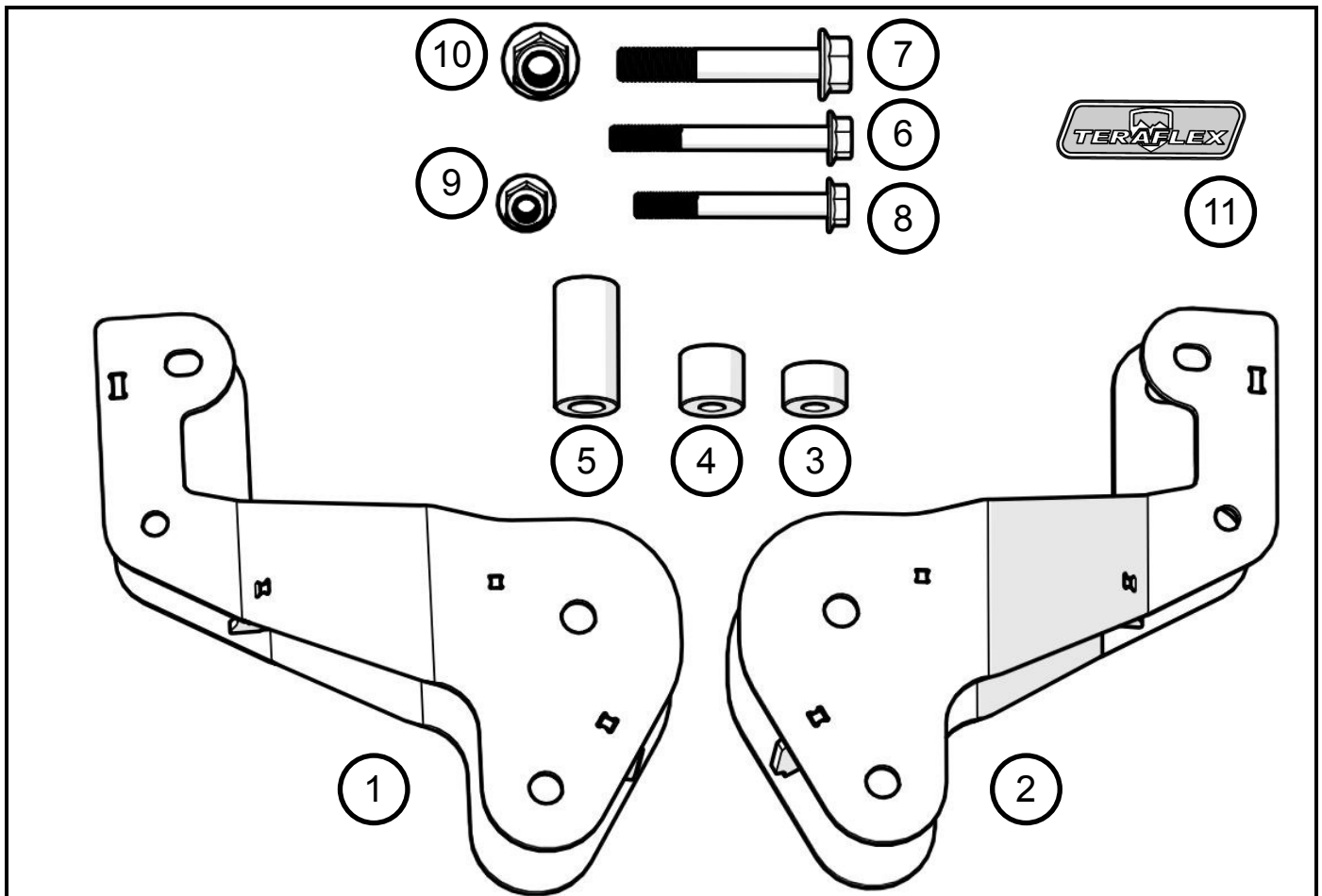

| Item No. | Part Number | Description | Qty |
|----------|------------------|--|-----|
| 1 | 15-07-001-001 | Bracket, Drop, Jeep JL Wrangler, Front / Driver | 1 |
| 2 | 15-07-002-001 | Bracket, Drop, Jeep JL Wrangler, Front / Passenger | 1 |
| 3 | 56-13-08-050-2-1 | Spacer, 1.25" OD, .75" Length, .500" ID, Aluminum 6061-T6 | 4 |
| 4 | 56-13-11-050-2-1 | Spacer, 1.25" OD, 1.05" Length, .500" ID, Aluminum 6061-T6 | 2 |
| 5 | 56-13-24-069-2-1 | Spacer, 1.25" OD, 2.43" Length, .6875" ID, Aluminum 6061-T6 | 2 |
| 6 | 45-02-003-008 | Hex Flange Bolt, Alloy Steel / Yellow Zinc, M12 x 1.75 x 110mm | 2 |
| 7 | 45-02-003-009 | Hex Flange Bolt, Alloy Steel / Yellow Zinc, M16 x 2.0 x 100mm | 2 |
| 8 | 45-02-003-014 | Hex Flange Bolt, Alloy Steel/Yellow Zinc, M12 x 1.75 x 80mm | 2 |
| 9 | 45-08-003-001 | Flange Top Lock Nut, Alloy Steel / Yellow Zinc, M12 X 1.75 | 4 |
| 10 | 45-08-003-002 | Flange Top Lock Nut, Alloy Steel / Yellow Zinc, M16 X 2.0 | 2 |
| 11 | 36-01-001-000 | Badge, Teraflex/Shield / Aluminum Flat | 2 |

NOTE: THIS INSTALLATION IS BEST DONE WITH THE JEEP ON THE GROUND AND WITH THE SUSPENSION LOADED.

If choosing to do installation while the Jeep is raised, refer to the factory service manual for safe lifting locations and support the front axle with a jack or jack stands.

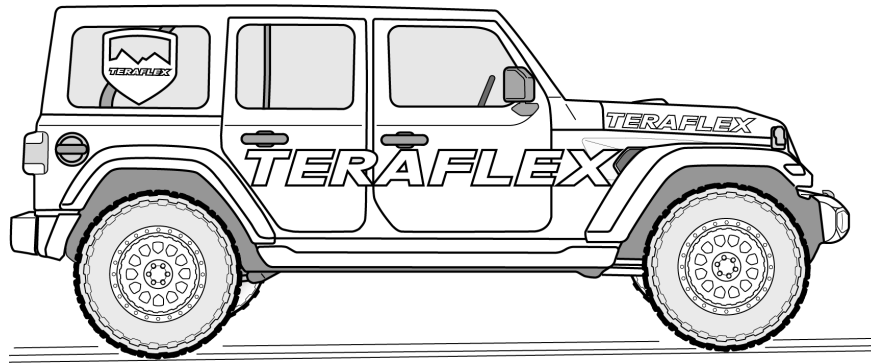

START ON THE DRIVER SIDE

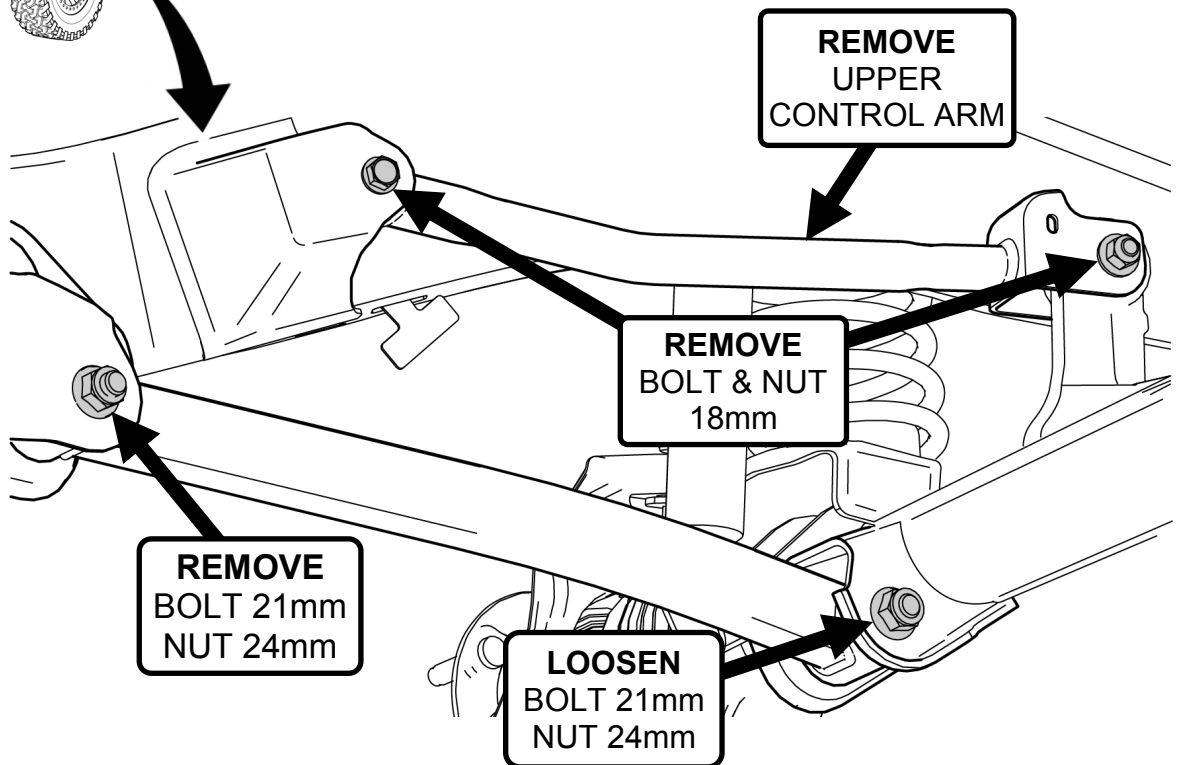
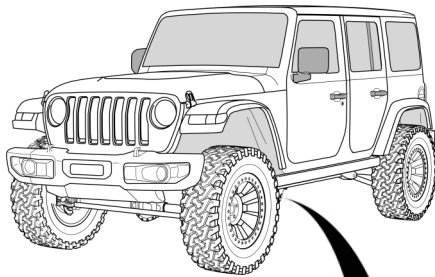

1

LOOSELY INSTALL DROP BRACKET ONTO LOWER CONTROL ARM BRACKET

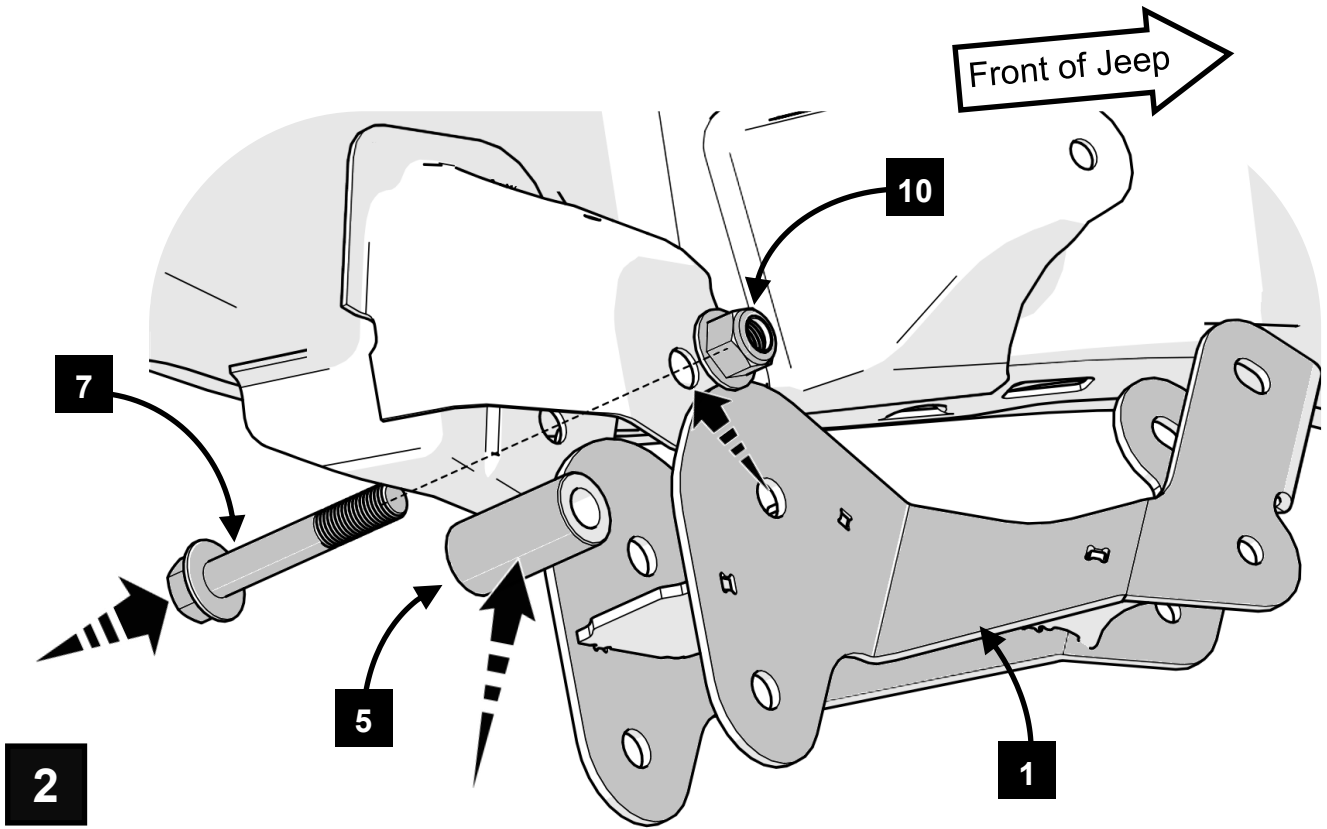

LOOSELY INSTALL DROP BRACKET ONTO UPPER CONTROL ARM BRACKET

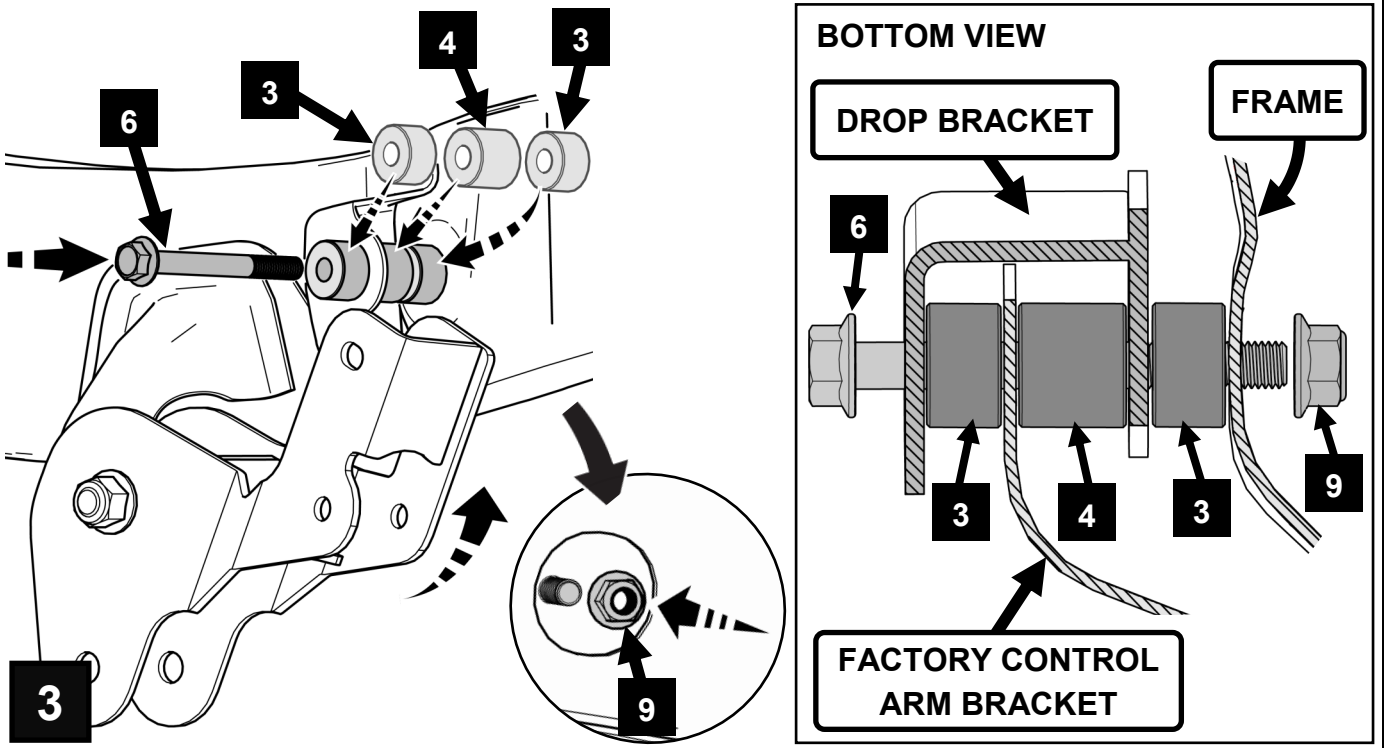

LOOSELY REINSTALL CONTROL ARMS

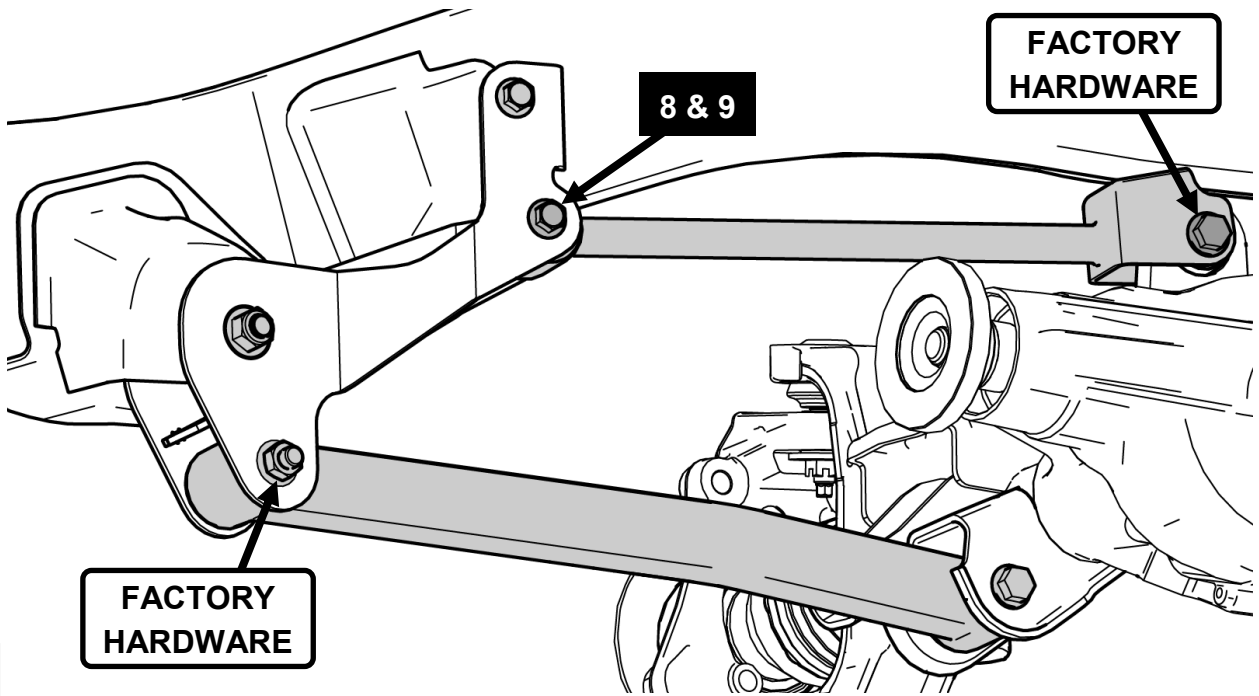

TORQUE HARDWARE

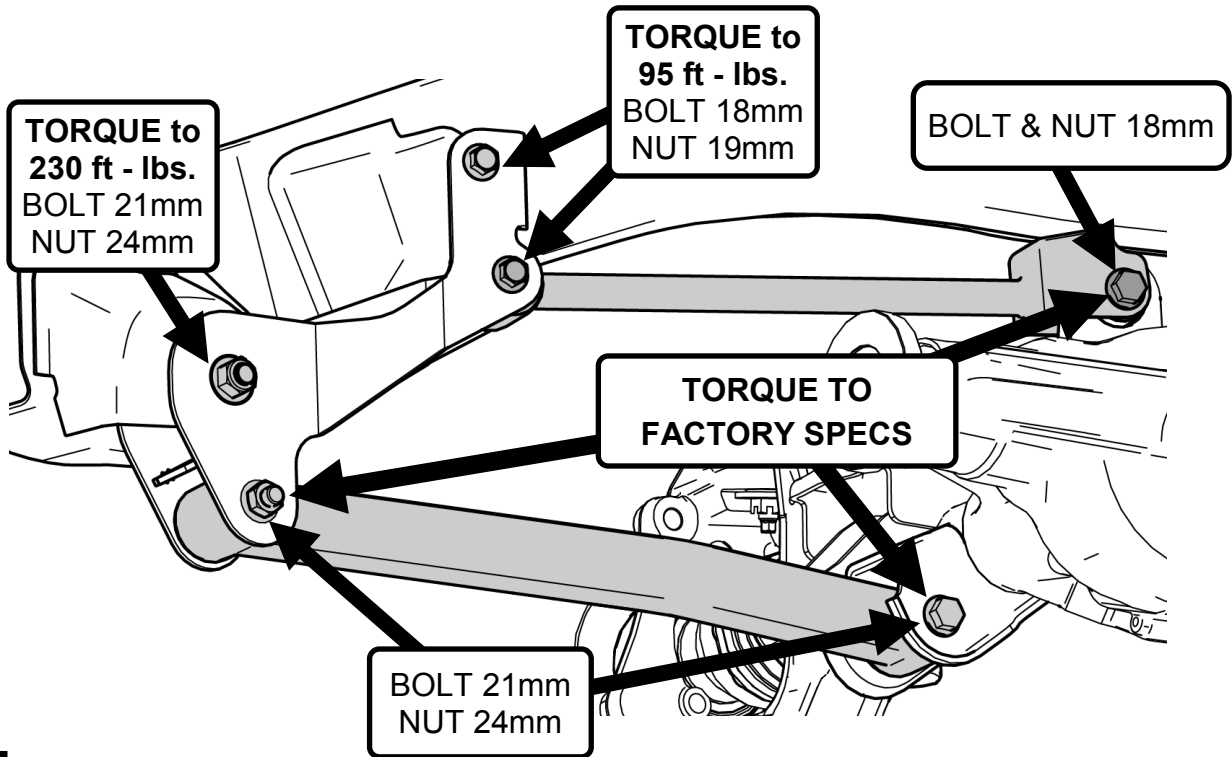

REPEAT STEPS 1-5 FOR THE PASSENGER SIDE

APPLY DECALS TO DROP BRACKETS

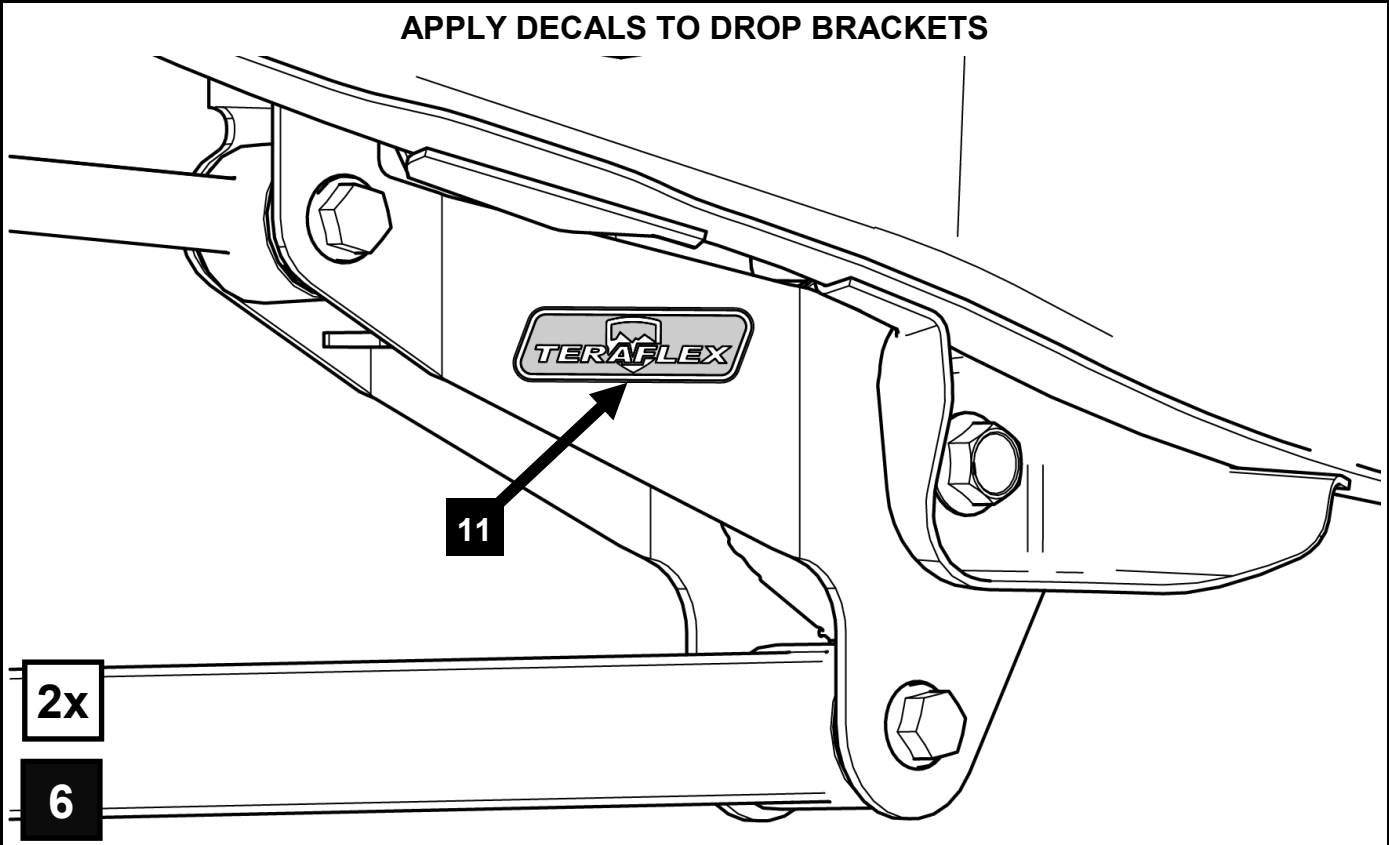

INSTALL IS NOW COMPLETE!

TERAFLEX

PRODUCT INFORMATION

MAINTENANCE INFORMATION:

It is the buyer's responsibility to have all suspension, drivetrain, steering, and other components checked for proper tightness and torque after the first 100 miles and every 3000 miles after that.

NOTICE TO INSTALLER:

The enclosed "Warning to Driver" sticker must be installed in the vehicle in driver's view. This sticker is to act as a constant safety reminder when operating the vehicle. It is your responsibility as the equipment installer to install the provided sticker and to forward the product instructions to the vehicle's owner for review. If a "Warning to Driver" sticker or product installation guide were not included in the kit, FREE replacement stickers and instructions are available by request. It is the installer's duty to ensure a safe and controllable vehicle after the modifications have been performed.

WARNING:

Neither the seller nor the manufacturer will be liable for any loss, damage, or injury directly or indirectly arising from the use of or inability to determine the use of these products. Before using, the user shall determine the suitability of the products for its intended use, and the user shall assume all responsibility and risk in connection therewith.

WARNING TO DRIVER:

This vehicle has been modified to enhance off road performance and has unique handling characteristics. Use in harsh environments can cause extreme stress on the components. Vehicle should be inspected after being off road to make sure that all the components are in working order and safe to travel on the highway. All fasteners should be checked so that they are at the correct torque specifications as the vibration and stresses from off roading may cause critical fasteners to work loose. Extra care should be taken to inspect the critical components, steering, and brake systems. During each oil change components such as arms, tie rod ends, etc should be greased and checked for excessive wear. Any worn components should be replaced. When returning to the pavement always set or restore tire air pressure to the factory recommendation and connect or engage any disabled sway bar mechanisms. Because of the higher center of gravity and larger tires, this vehicle handles and reacts differently than many passenger cars, both on and off road. You must drive it safely! Extreme care should be taken to prevent vehicle rollover or loss of control, which can result in serious injury or death. Avoid sudden sharp turns or abrupt maneuvers. Generally, braking performance and capabilities are decreased when significantly larger/heavier tires are used, especially when used in combination with transfer case low-range reduction kits. Take this into consideration while driving. Do not add, alter or fabricate any factory or aftermarket parts to increase vehicle height over the intended height of the TeraFlex product purchased. Mixing component brand is not recommended. TeraFlex Inc. will not be responsible for any altered product or any improper installation or use of our products. We will be happy to answer any questions concerning the design, function, and correct use of our products. It is ultimately the buyer's responsibility to have all bolts/nuts checked for tightness after the first 100 miles and then every 3000 miles. Wheel alignment, steering system, suspension and drive line systems must be inspected by a qualified professional mechanic at least every 3000 miles.