

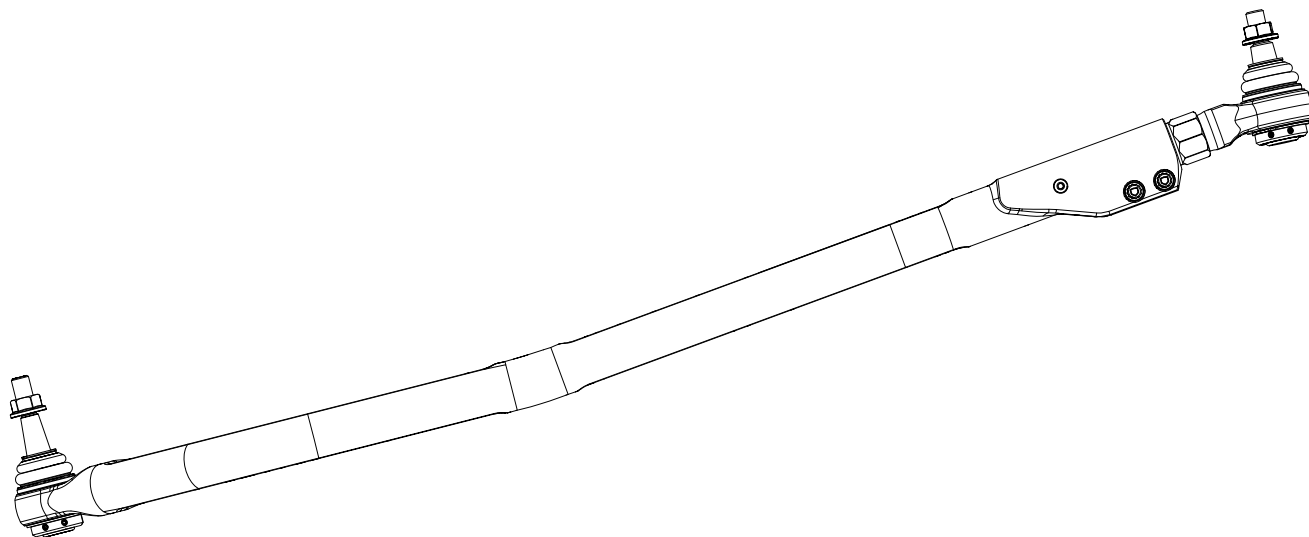

# JEEP JL/JT PREMIUM HD FORGED DRAG LINK KIT INSTRUCTIONS

# 1863920



## Important Notes:

Prior to beginning this install, or any installation, read the instructions thoroughly to familiarize yourself with the required steps. Evaluate if you are experienced and capable to personally perform these modifications. A factory service manual should be used in conjunction with these installation instructions.

This product will change the highway handling characteristics of your vehicle, exercise caution. After altering the suspension it is always advisable to have an alignment done by a competent 4 wheel drive shop or by an alignment shop that is experienced with lifted 4 wheel drive vehicles.

Refer to the parts list to ensure that all necessary components and hardware has been included. If any parts are missing please contact your local TeraFlex dealer for assistance.

**When reinstalling OEM hardware, refer to the torque specs given in the Factory Service Manual.**

## Tools Needed:

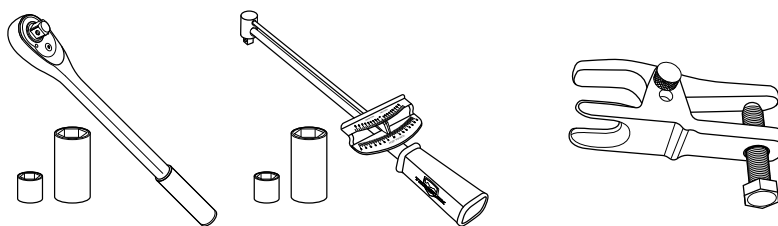

## Maintenance Note:

After the first 300 miles and every 3,000 miles after that, re-torque all the suspension components and bolts.

**INSTALL DUST BOOT RETAINING SPRINGS AND GREASE ZERK RUBBER PLUGS**

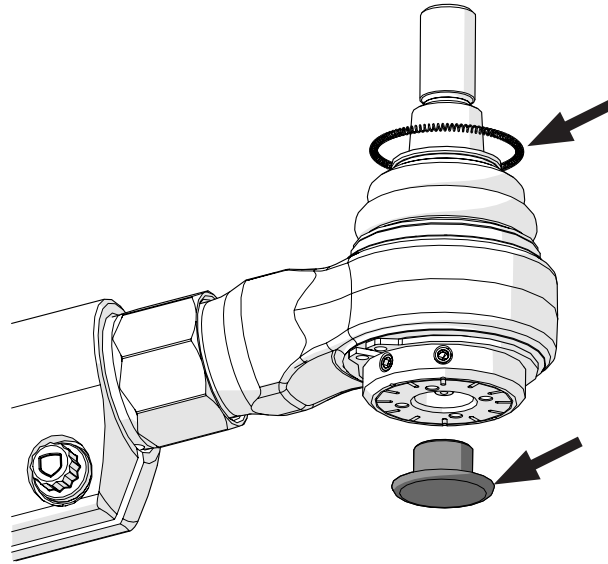

**1**

**REMOVE SWAY BAR LINKS AT THE AXLE**

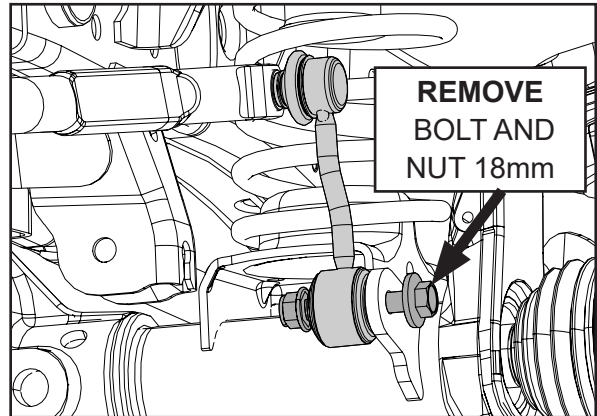
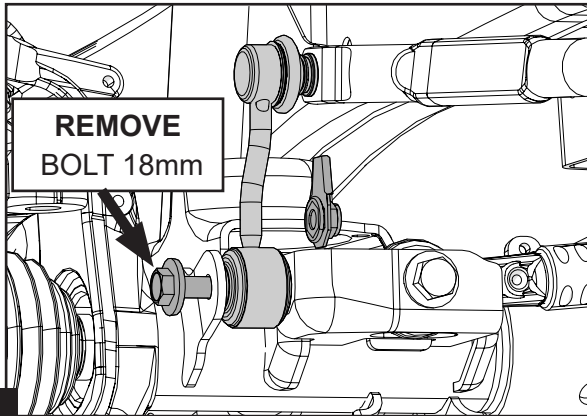

**2**

**PUSH SWAY BAR UP OUT OF THE WAY**

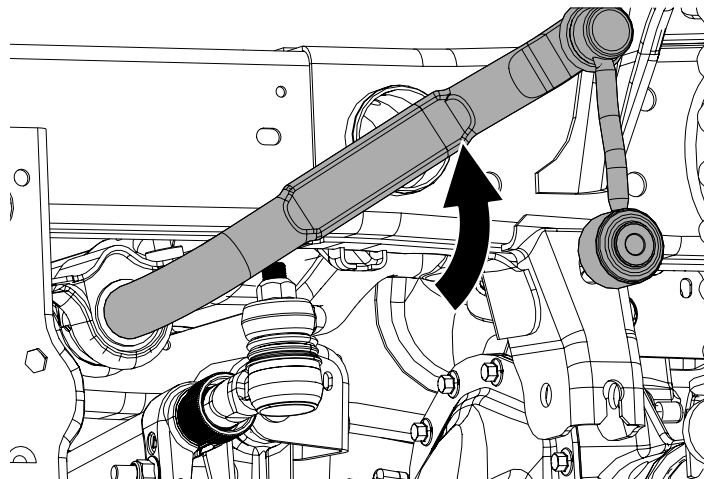

**3**

### REMOVE DRAG LINK FROM PITMAN ARM

LOOSEN NUT  
DO NOT REMOVE  
NUT 21mm

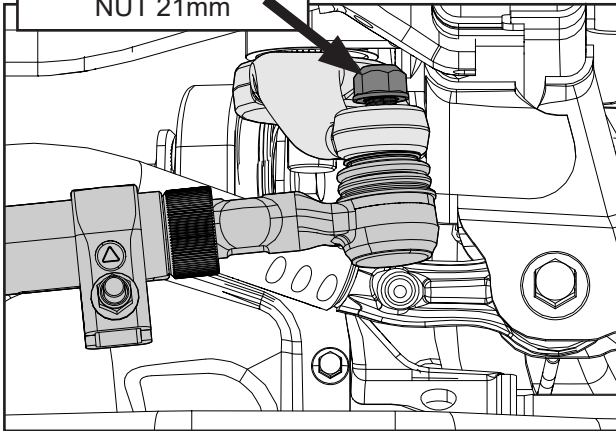

BREAK DRAG LINK FREE USING  
BALL JOINT TOOL AND  
REMOVE FROM PITMAN ARM

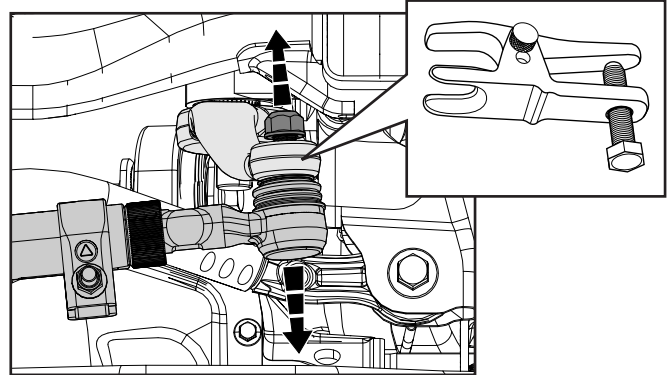

4

### REMOVE DRAG LINK FROM KNUCKLE

LOOSEN NUT  
DO NOT REMOVE  
NUT 21mm

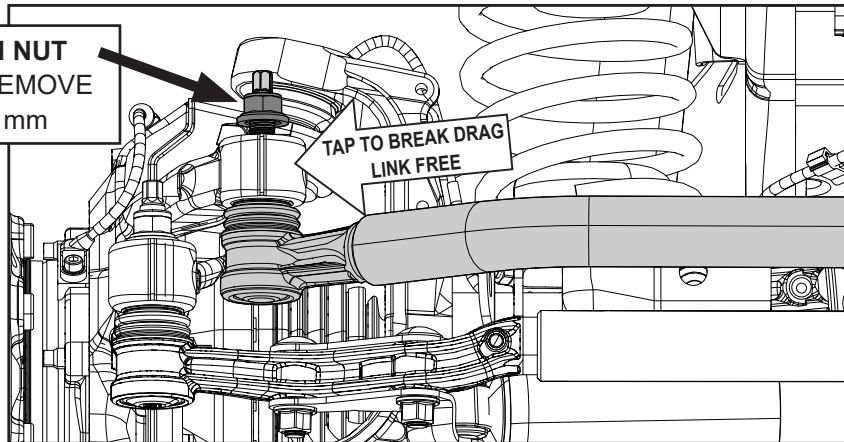

TURN KNUCKLE AND  
REMOVE DRAG LINK FROM  
KNUCKLE

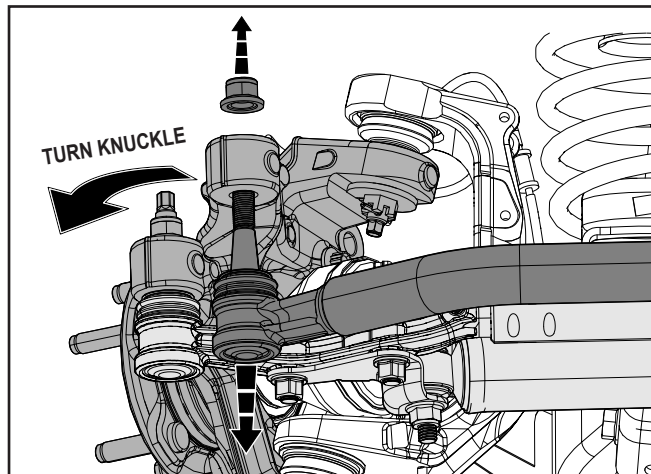

5

### INSTALL HD DRAG LINK

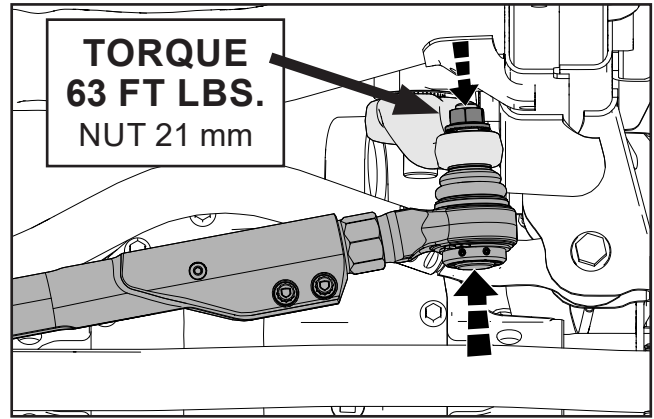
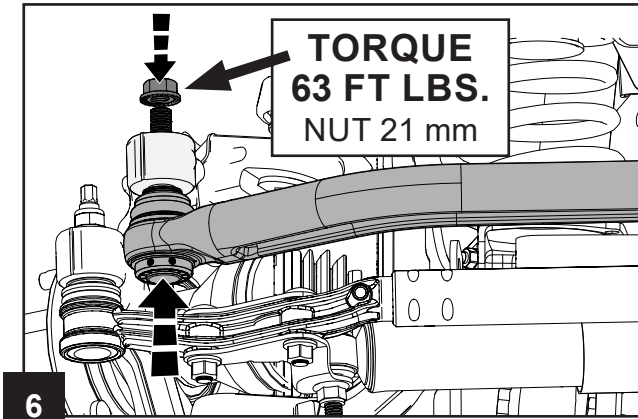

### ADJUST STEERING WHEEL

**NOTE: TURN WHEELS STRAIGHT BEFORE CENTERING THE STEERING WHEEL**

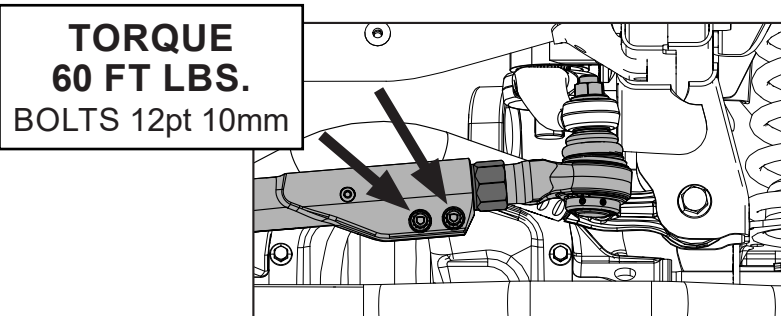
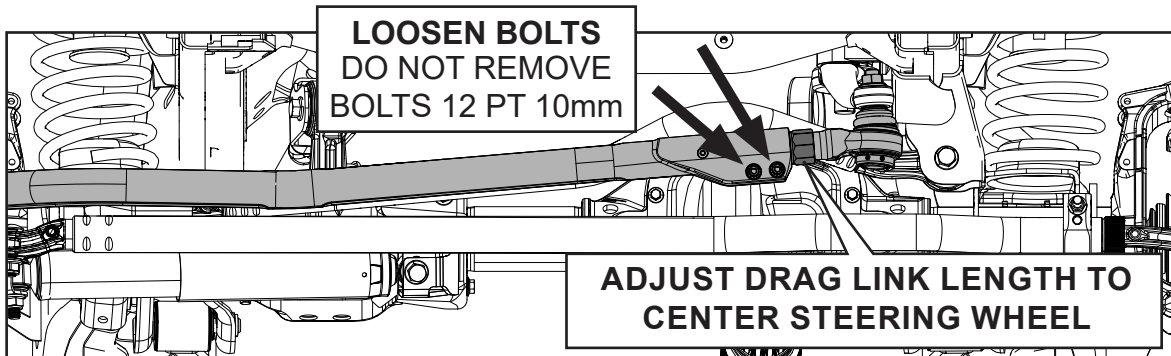

### REINSTALL SWAY BAR LINKS

