

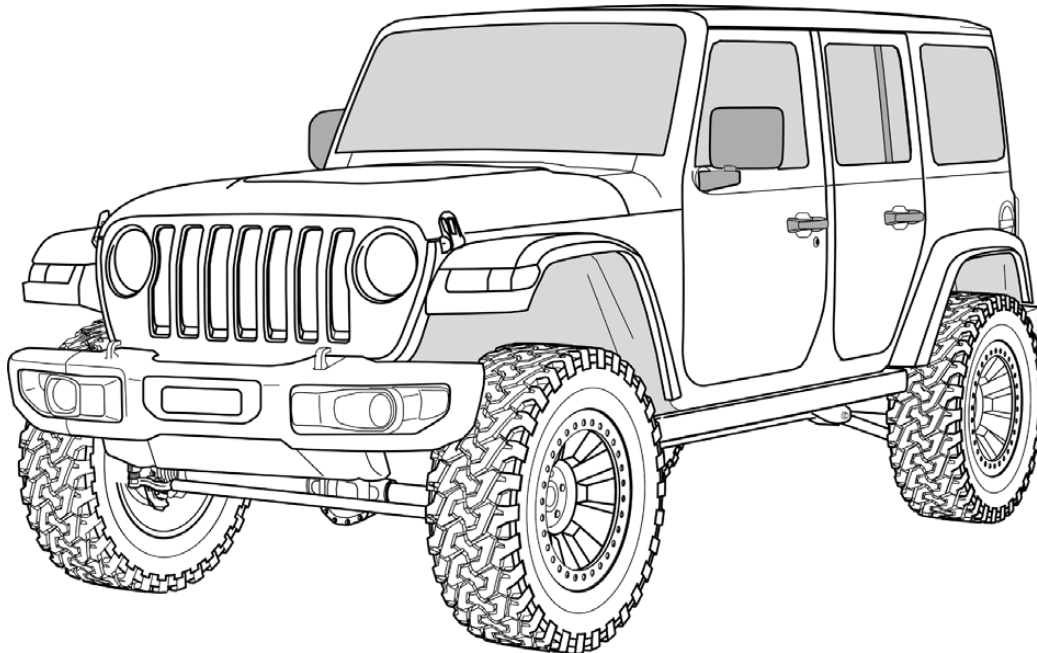

Jeep JL 3.5" Spring Lift



Important Notes:

Prior to beginning this install, or any installation, read the instructions thoroughly to familiarize yourself with the required steps. Evaluate if you are experienced and capable to personally perform these modifications. A factory service manual should be used in conjunction with these installation instructions.

This product will change the highway handling characteristics of your vehicle, exercise caution. After altering the suspension it is always advisable to have an alignment done by a competent 4 wheel drive shop or by an alignment shop that is experienced with lifted 4 wheel drive vehicles.

Refer to the parts list to ensure that all necessary components and hardware has been included. If any parts are missing please contact your local TeraFlex dealer for assistance.

NOTE: Some form of caster correction is required for the base spring lift kit

If a 37" tire is being installed on a Sport or Sahara additional up travel limit may be required using Bumpstop Spacer Kit #1959300.













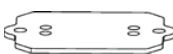
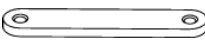

Tools Needed:



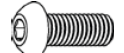

- Metric Sockets and Open End Wrenches
- Torque Wrench
- Drill and 1/2" Drill Bit
- Factory Service Manual
- General Mechanics Tools

Maintenance Note:

After the first 300 miles and every 3,000 miles after that, re-torque all the suspension components and bolts.

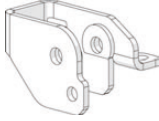
Spring Box Components

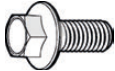
	Description	Item #	Alpine CT3		Sport ST3		Base Spring Lift	
			4DR	2DR	4DR	2DR	4DR	2DR
	1 Front	02-21-401-250-1	2	-	2	-	2	-
		02-21-201-250-1	-	2	-	2	-	2
	2 Rear Left	02-22-411-250-1	1	-	1	-	1	-
		02-22-211-250-1	-	1	-	1	-	1
	3 Rear Right	02-22-421-250-1	1	-	1	-	1	-
02-22-221-250-1		-	1	-	1	-	1	
	4 Front Bumpstops	12-01-109-200	2	2	2	2	2	2
	5 Rear Bumpstops	12-01-209-200	2	2	2	2	2	2
	6 Rear Bumpstop Bracket	12-02-209-002	2	2	2	2	2	2
	7 Rear Bumpstop Mounting Strap	12-02-209-001	2	2	2	2	2	2
	8 Front Bumpstop Spacers	12-02-109-050	4	4	4	4	4	4
	9 Rear Bumpstop Spacers	12-02-209-050	4	4	4	4	4	4
	10 Brake Line Anchor Kit	1101255	1	1	1	1	1	1
	11 Front Swaybar link 10.75"	744500	2	2	2	2	2	2
	12 Rear Swaybar Link 11.50	21-01-001-115	2	2	2	2	2	2
	13 M10 x 1.5 Fuji Nut	23-07-03-001	6	6	6	6	6	6
	14 M10 x 1.5 x 100mm Flat Socket Cap Screw	45-04-003-001	2	2	2	2	2	2
	15 M10 x 1.5 x 50mm Socket Cap Screw	45-03-003-001	4	4	4	4	4	4
	16 M10 x 1.5 x 25mm Button Socket Cap Screw	45-05-003-003	4	4	4	4	4	4
	17 M10 Lock Washer	45-12-002-001	4	4	4	4	4	4
	18 Nut Wrench Tool	600271	1	1	1	1	1	1
	19 M12 x 1.75 x 55mm Button Socket Cap Screw	45-05-003-001	2	2	2	2	2	2
	20 M12 x 1.75mm Black Fuji Nut	23-07-02-002	2	2	2	2	2	2

Spring Box Components	Description	Item #	Alpine CT3		Sport ST3		Base Spring Lift	
			4DR	2DR	4DR	2DR	4DR	2DR
				21 Front Track Bar Bracket	15-04-109-006	1	1	1
	22 M12 x 1.75 Flanged Serrated Nut	45-12-003-001	1	1	1	1	1	1
	23 M14 x 2.0 x 80mm Hex Flange Bolt	45-02-003-011	1	1	1	1	1	1
	24 M12 x 1.75 x 25mm Hex Flange Bolt	45-02-003-013	2	2	2	2	2	2
	25 M12 X 1.75 Flange Top Lock Nut	45-08-003-001	1	1	1	1	1	1
	26 M14 x 2.0 Flange Top Lock Nut	45-08-003-003	1	1	1	1	1	1

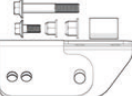
Description	Item #	Alpine CT3		Sport ST3		Base Spring Lift		
		4DR	2DR	4DR	2DR	4DR	2DR	
	Jounce Bumpers Kit	1959200	1	1	1	1	-	-
	Alpine Control Arm Kit	1416510	1	1	-	-	-	-
	Front Arm Drop Bracket Kit	1938125	-	-	1	1	-	-
	Rear Track Bar Kit	1953600	1	1	1	1	1	1

Note: If installing Alpine Control Arm Kit Refer to Instruction #999321 before continuing.

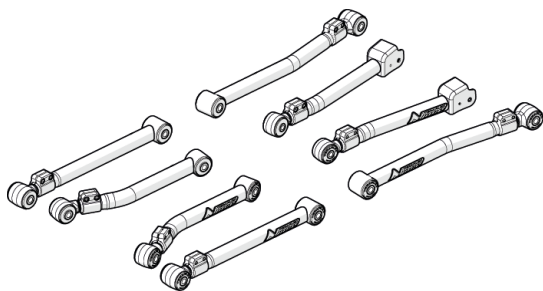

Note: If installing Front Drop Bracket Kit Refer to Instruction #999309 before continuing.

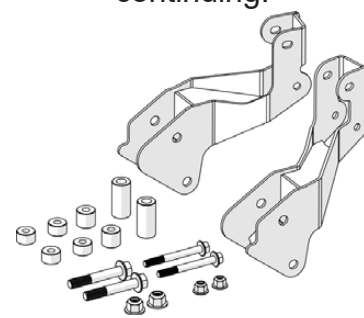

LEAVE CONTROL ARM BOLTS LOOSE UNTIL THE END OF THE LIFT INSTALLATION

FRONT INSTALLATION LIFT AND SUPPORT AT FRAME

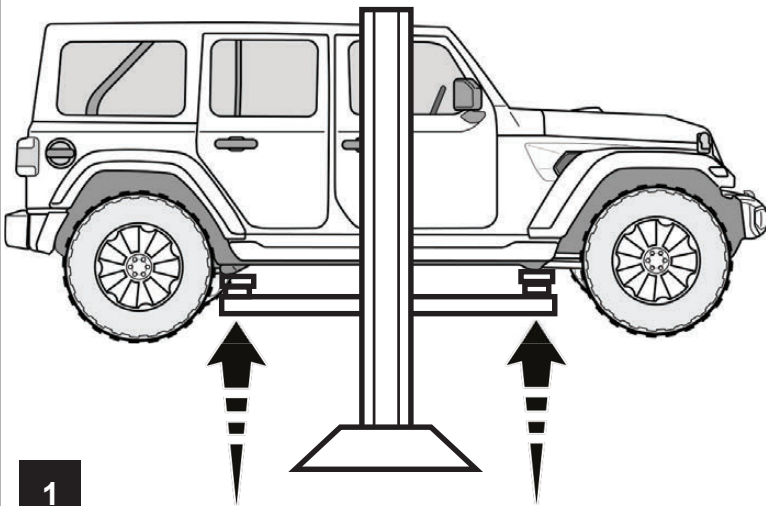
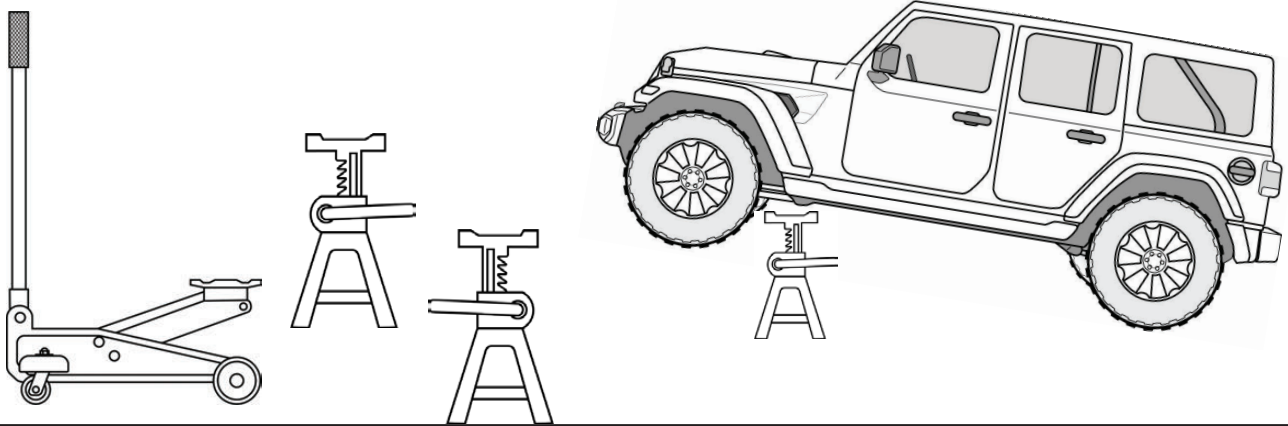

REMOVE FRONT TIRES

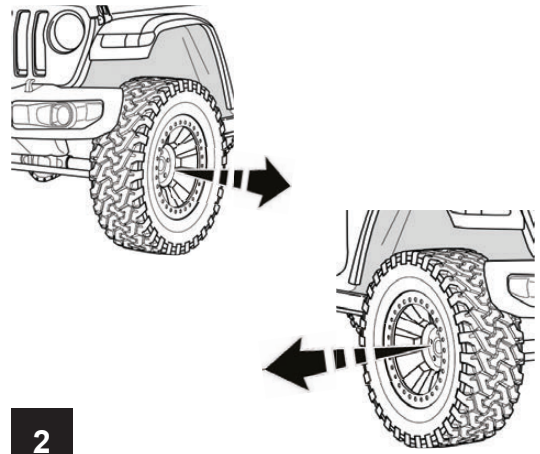

SUPPORT FRONT AXLE

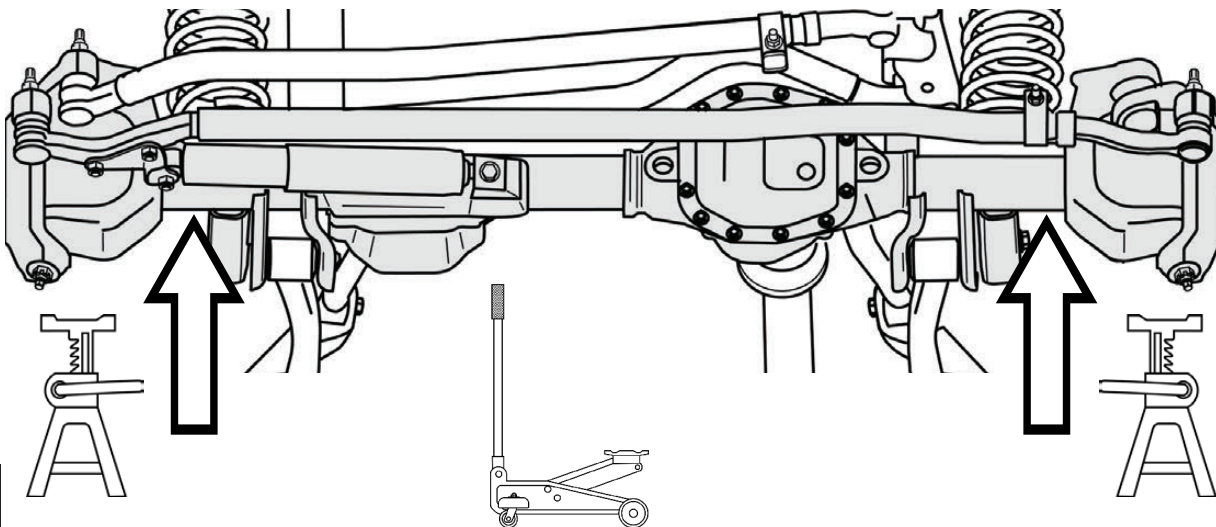

REMOVE SWAY BAR LINKS & REMOVE TRACK BAR BOLT AT AXLE

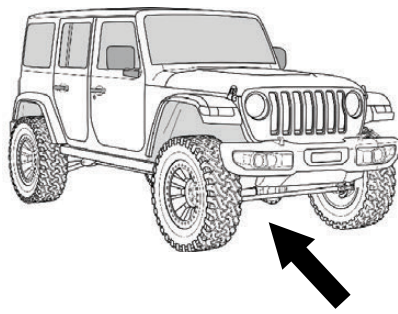

**REMOVE &
DISCARD**

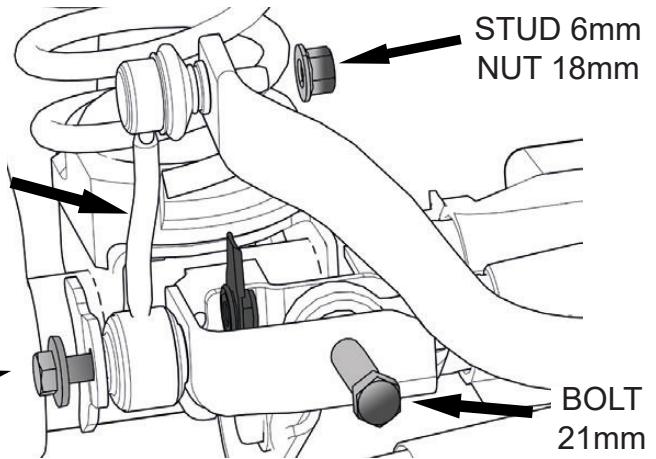

4

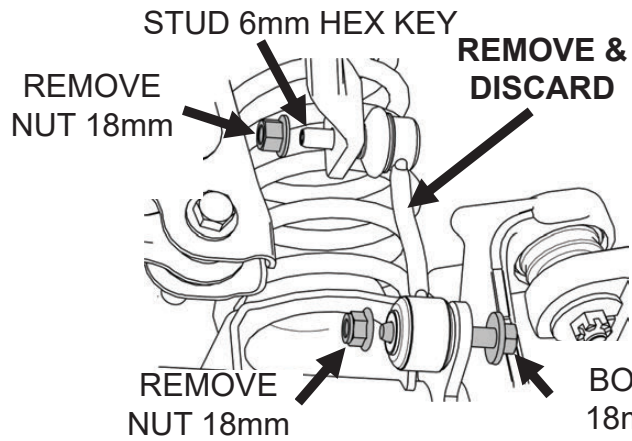
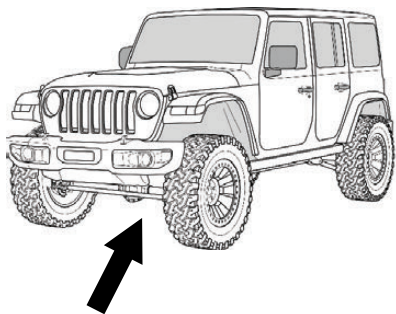

5

REMOVE AND DISCARD BRAKE LINE BRACKETS FROM LOWER CONTROL ARMS AND SPRING MOUNTS

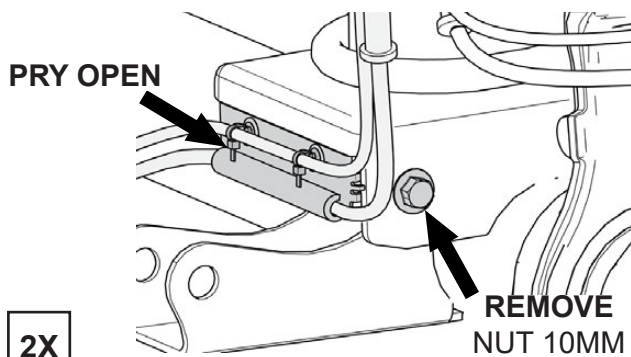

2X

6

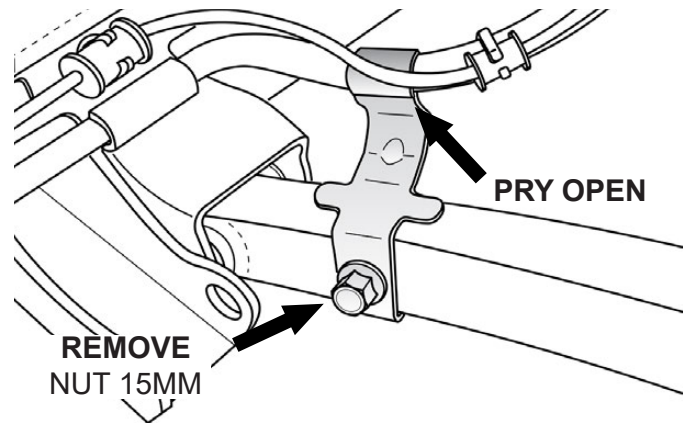

DISCONNECT ACTUATORS AND VENT HOSE AT THE FRONT AXLE

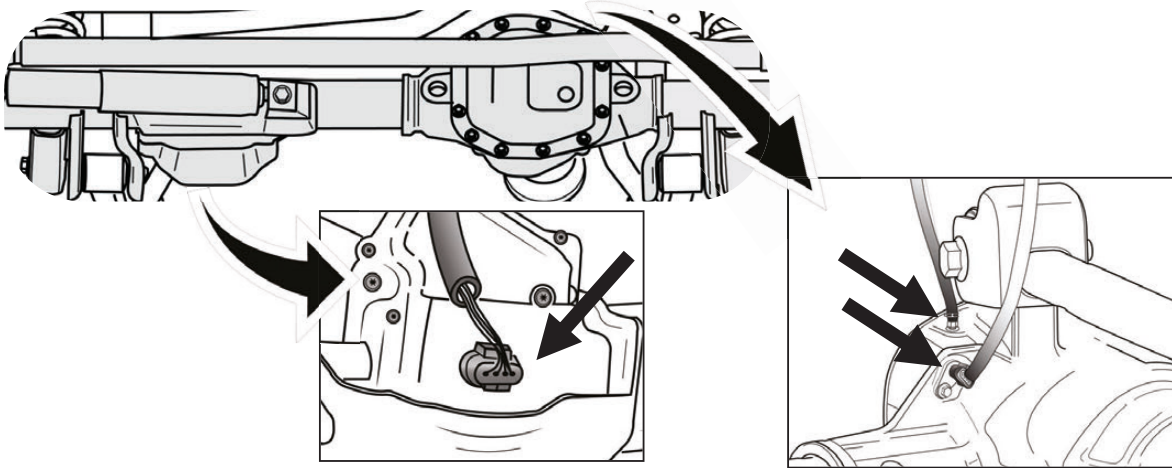

7

**LOOSEN FRONT CONTROL ARM BOLTS
DO NOT REMOVE THE CONTROL ARM BOLTS**

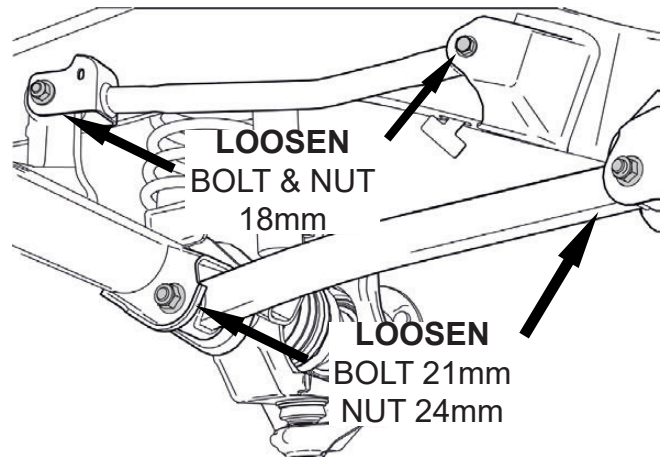
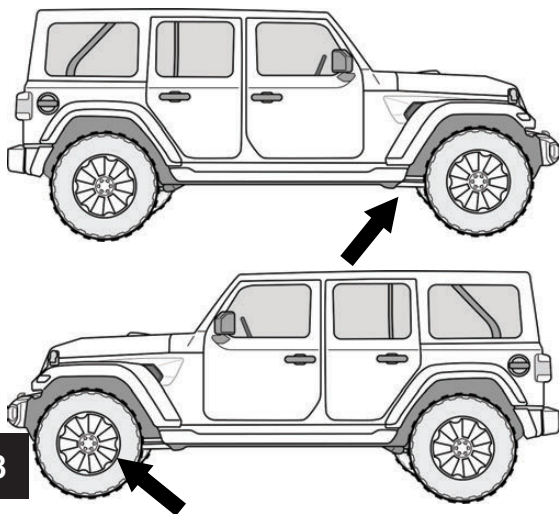

8

REMOVE FRONT SHOCKS

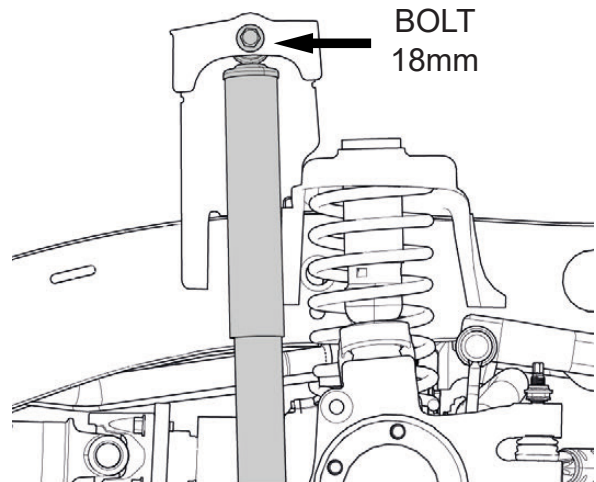
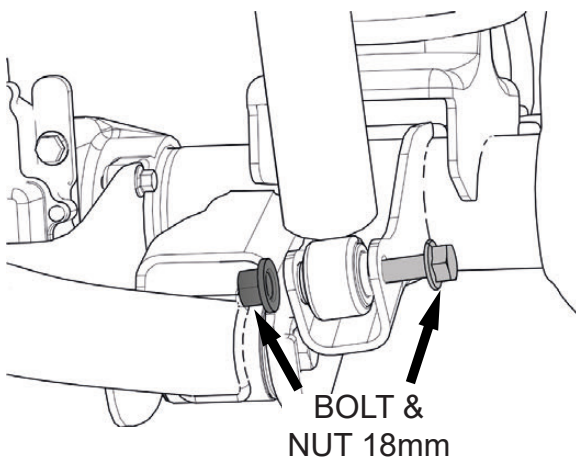

2X

9

LOWER AXLE AND REMOVE FRONT SPRINGS

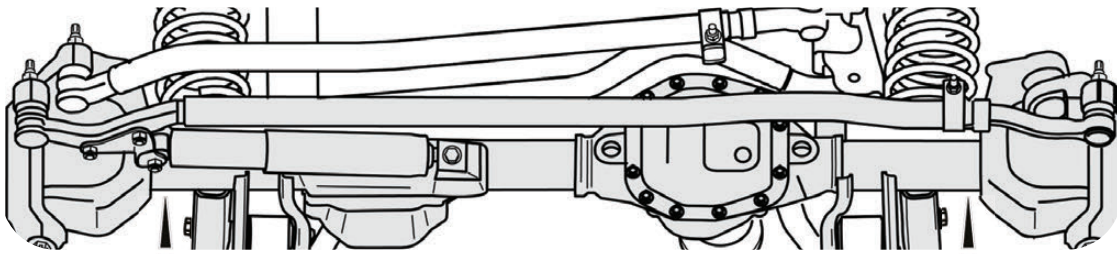

NOTE: REMOVE ANY PLASTIC RETAINERS FROM WIRING OR HOSES AS NEEDED.

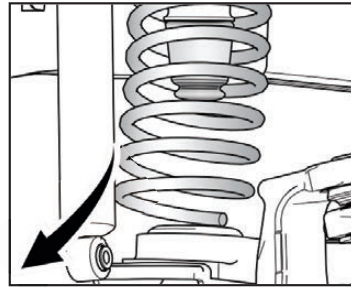

2X

10

Note: If installing Falcon Jounce Bumpers refer to instruction #999308 before installing springs.



2X

11

INSTALL BUMPSTOP INTO NEW FRONT SPRING

TIP: ZIP TIE BUMPSTOP TO SPRING

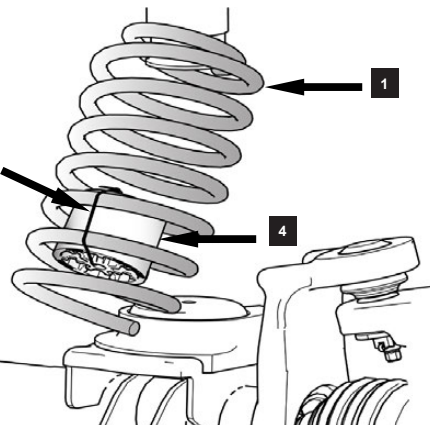

2X

12

**NOTE: REFER TO PAGE 19
FOR BUMPSTOP SPACER
GUIDE**

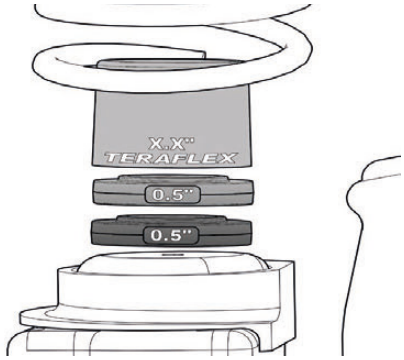

2X

13

**TORQUE
12 FT-LBS**

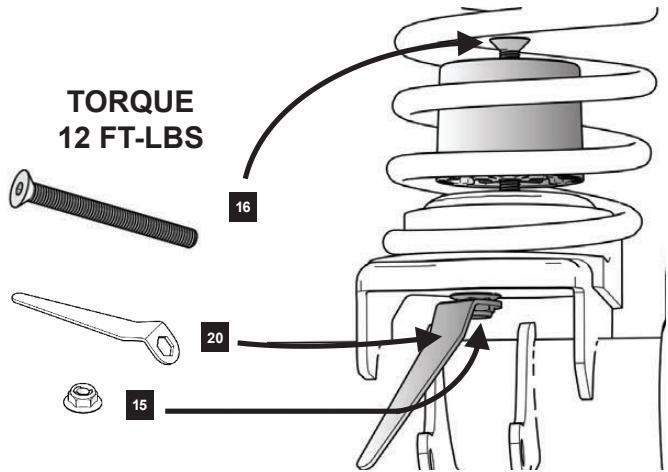

FULLY SEAT THE SPRINGS INTO THE LOWER SPRING ISOLATOR

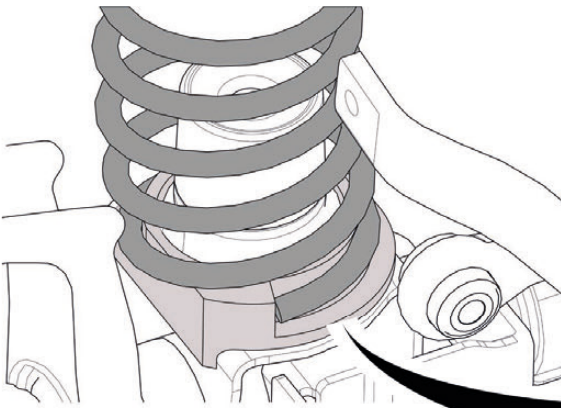

2X

14

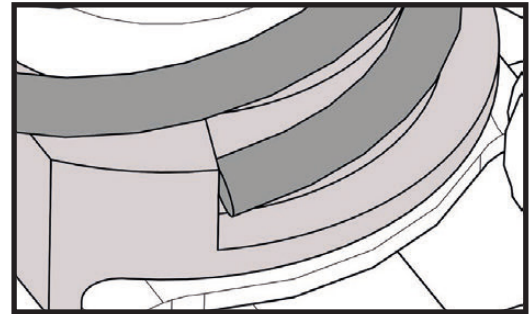

RAISE AXLE & INSTALL SHOCKS

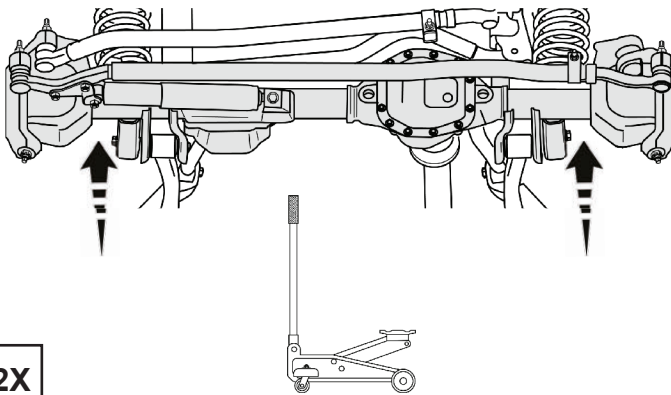

2X

15

**INSTALL FRONT FALCON SHOCKS AT
THIS TIME**

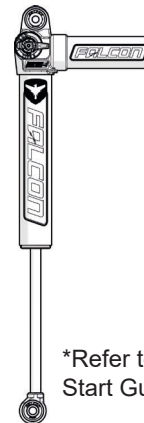

***Refer to the Quick
Start Guide.**

INSTALL BRAKE LINE ANCHORS

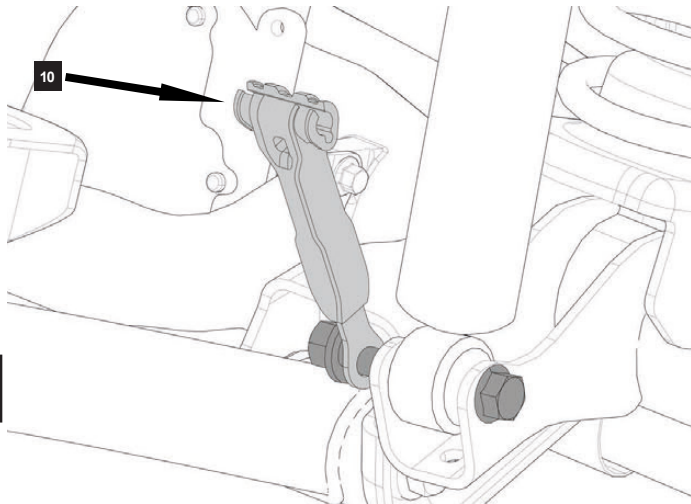

REFER TO THE INSTRUCTIONS ON THE BACK OF THE BRAKE LINE ANCHOR KIT BOX FOR PROPER INSTALLATION.

INSTALL NEW SWAY BAR LINKS

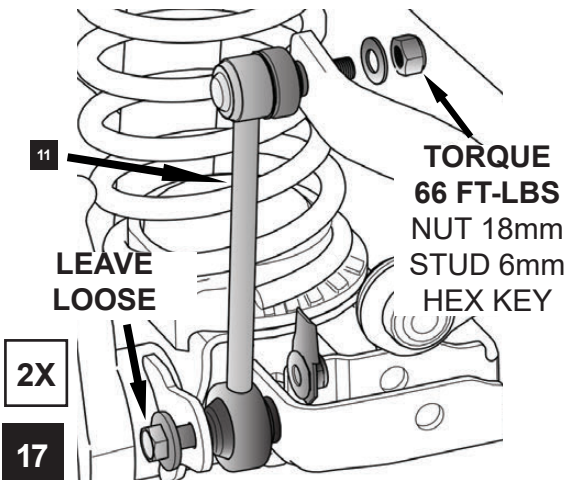

RECONNECT CONNECTIONS TO FRONT AXLE

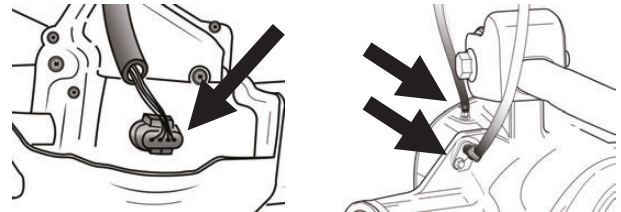

RECONNECT PLASTIC RETAINERS FROM WIRING OR HOSES AS NEEDED.

NOTE: DO NOT TIGHTEN THE CONTROL ARM BOLTS UNTIL THE JEEP IS ON THE GROUND

18 WAIT TO RE-INSTALL TRACK BAR UNTIL THE END OF THE LIFT KIT INSTALL.

NOTE: IF ONLY FRONT OF JEEP WAS LIFTED, REINSTALL TIRES AND LOWER JEEP BACK TO THE GROUND BEFORE LIFTING THE REAR

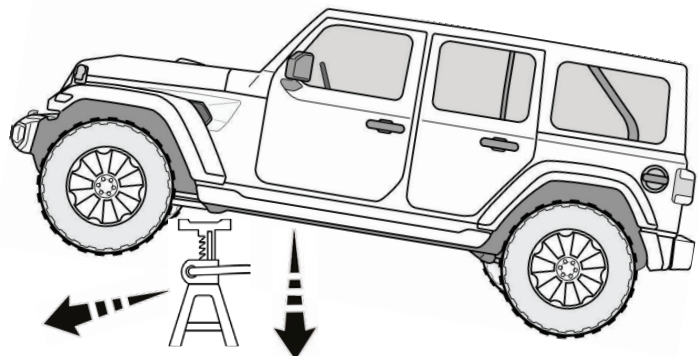
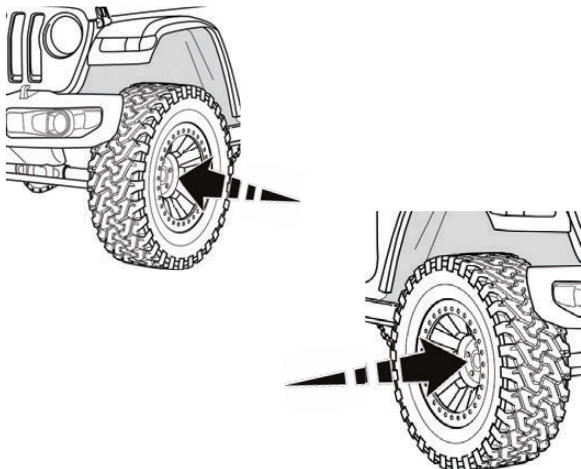

**REAR INSTALL
LIFT AND SUPPORT AT FRAME**

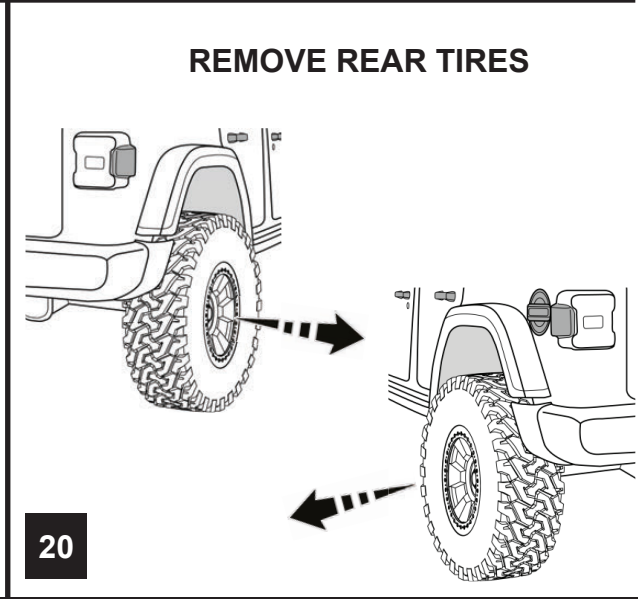
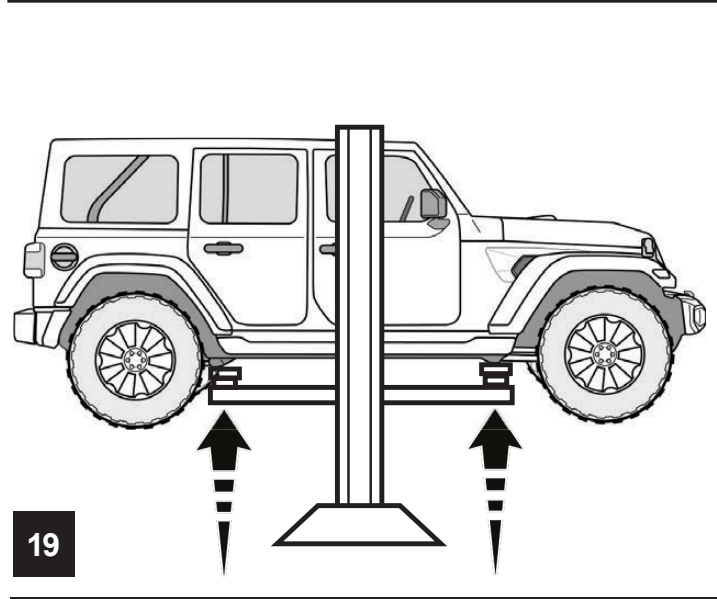
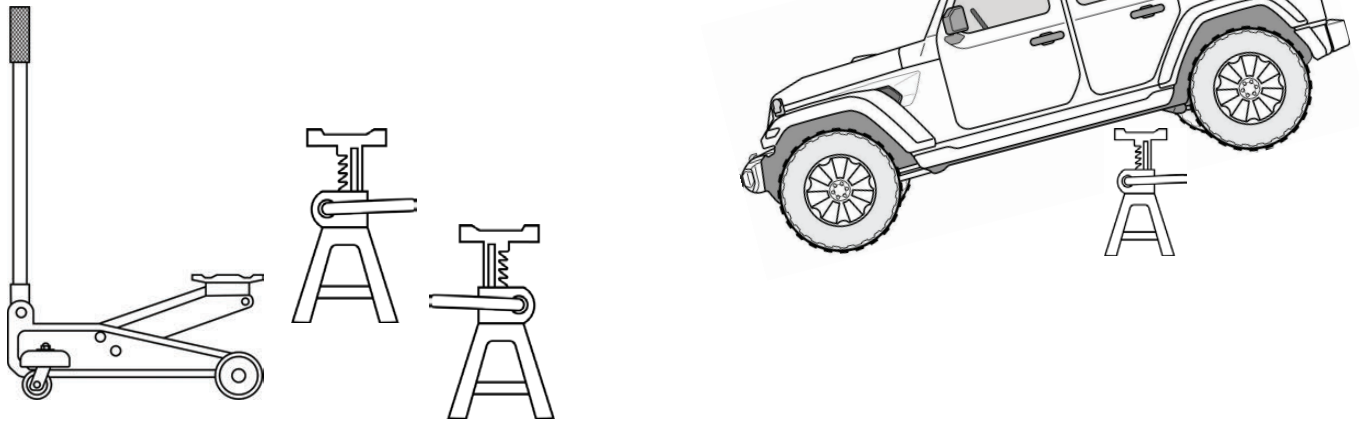

SUPPORT REAR AXLE

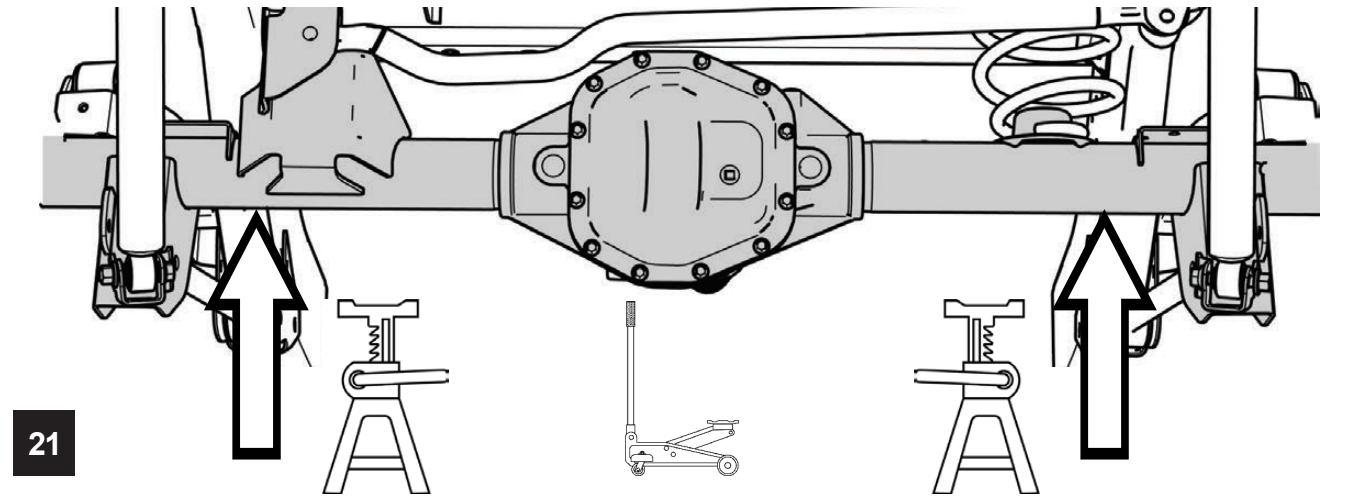

REMOVE E-BRAKE CABLE BRACKET AND DISCARD

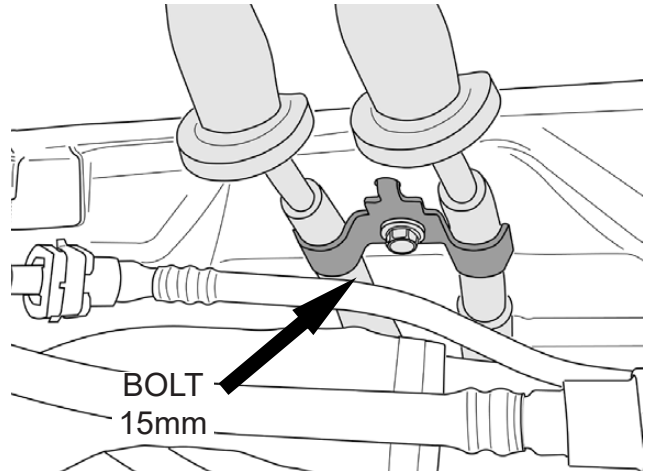
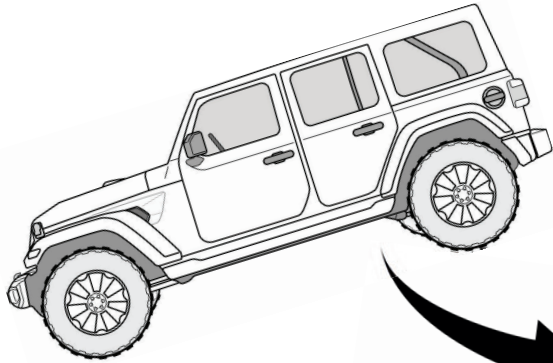

22

SET THE E-BRAKE AND CLAMP BOTH E-BRAKE EYELETS AGAINST BACKING PLATES WITH LOCKING PLIERS

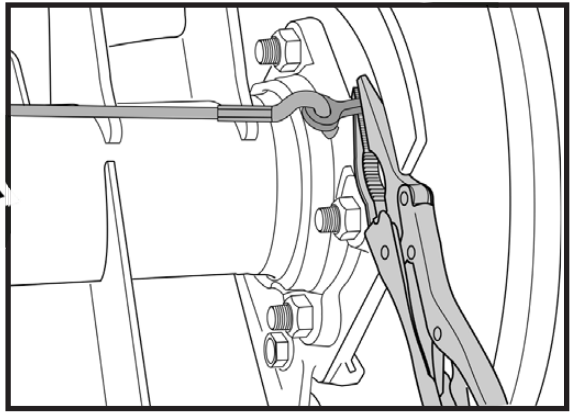
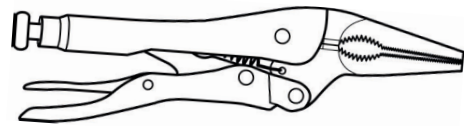
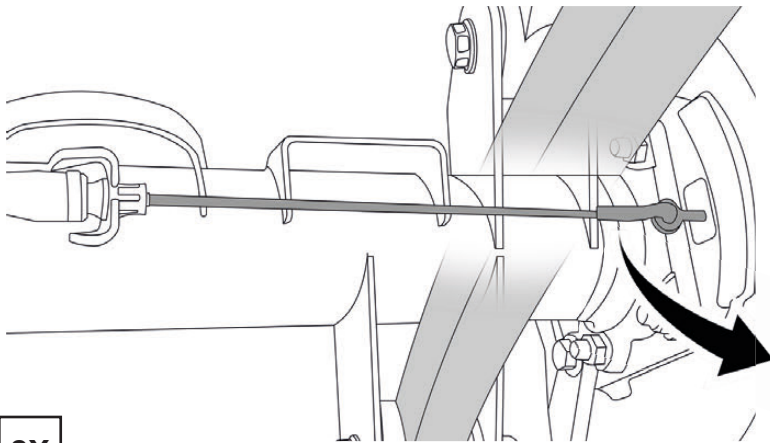

2X

23

RELEASE E-BRAKE AND DISCONNECT CABLES FROM BOTH EYELETS AND AXLE BRACKETS

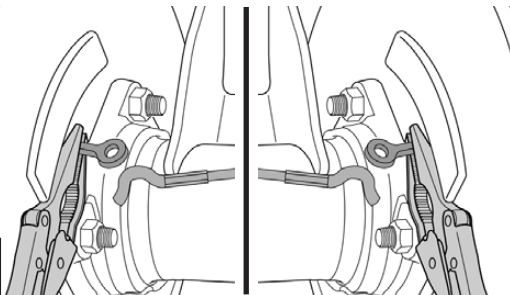

2X

24

NOTE: DO NOT REMOVE LOCKING PLIERS FROM E-BRAKE EYELETS

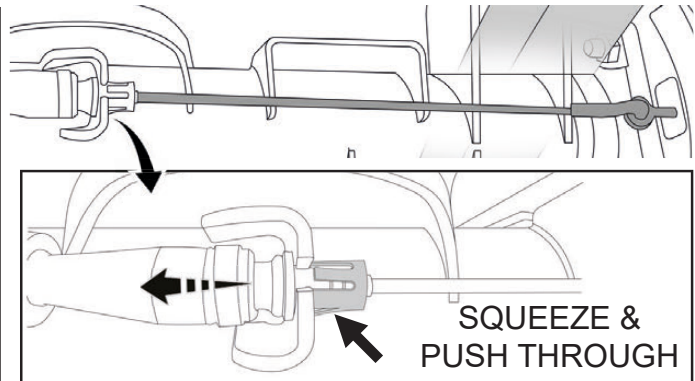

**ROUTE E-BRAKE CABLES UNDER
CROSS MEMBER AND FUEL LINES.**

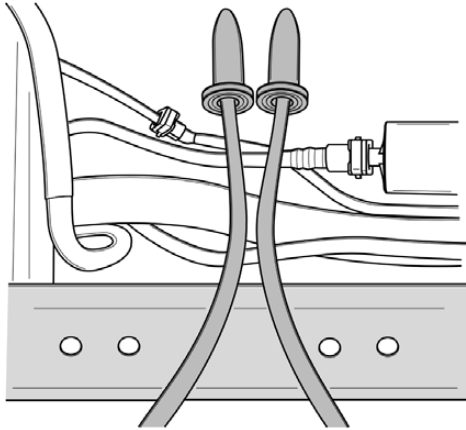

25

**RECONNECT E-BRAKE CABLES TO THE
AXLE BRACKETS AND THEN THE
E-BRAKE EYLETTS.**

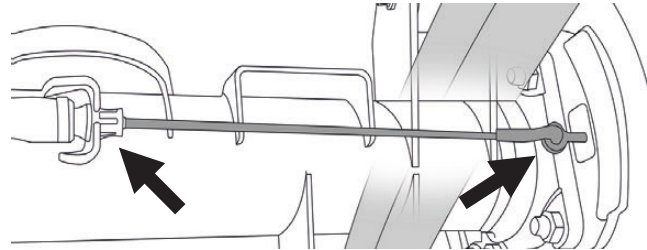

2X

**REMOVE PLIERS FROM
E-BRAKE EYLETTS**

26

LOOSEN REAR CONTROL ARM BOLTS

DO NOT REMOVE THE CONTROL ARM BOLTS

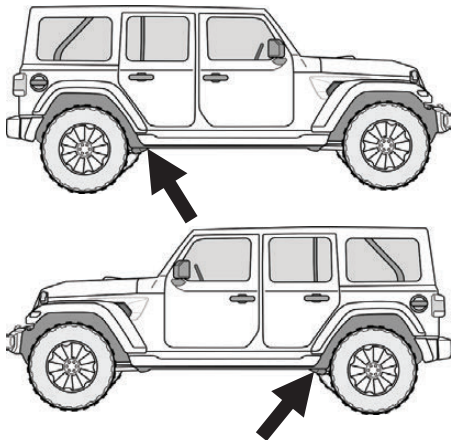

2X

27

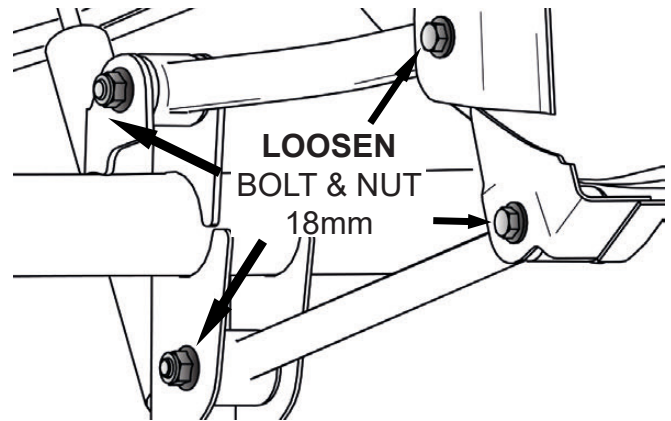

REMOVE AND DISCARD SWAY BAR LINKS

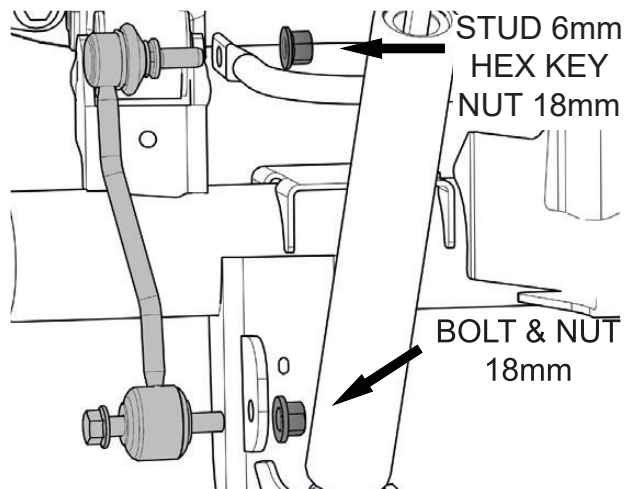

2X

28

REMOVE BRAKE LINE BRACKETS FROM BOTH SIDES OF THE AXLE

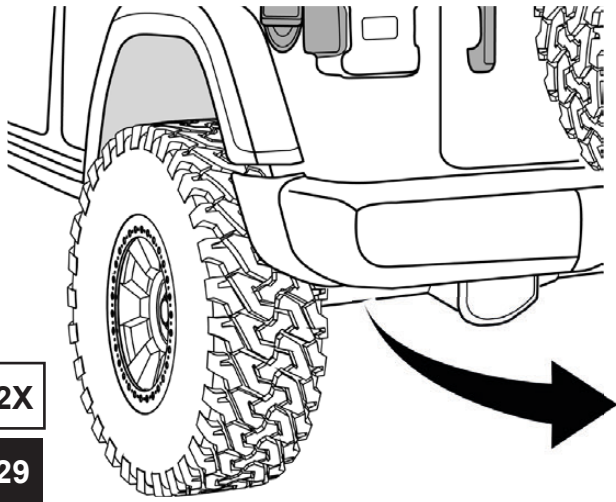

2X
29

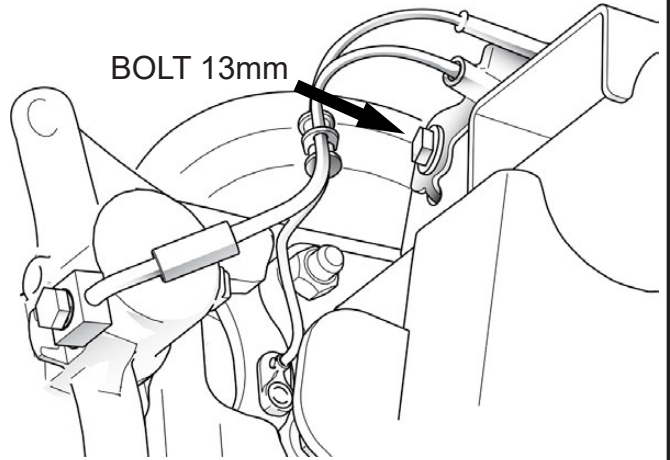

REMOVE THE TRACK BAR FROM THE AXLE

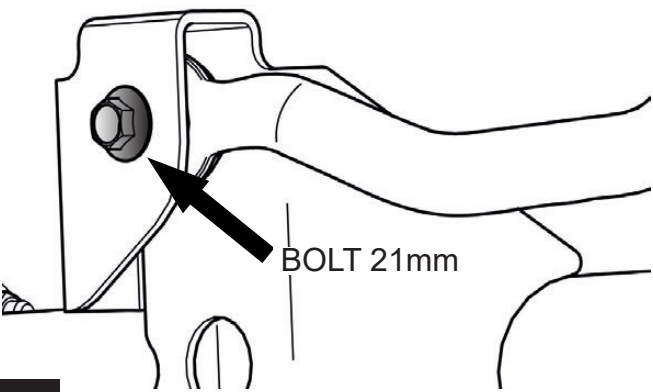

30

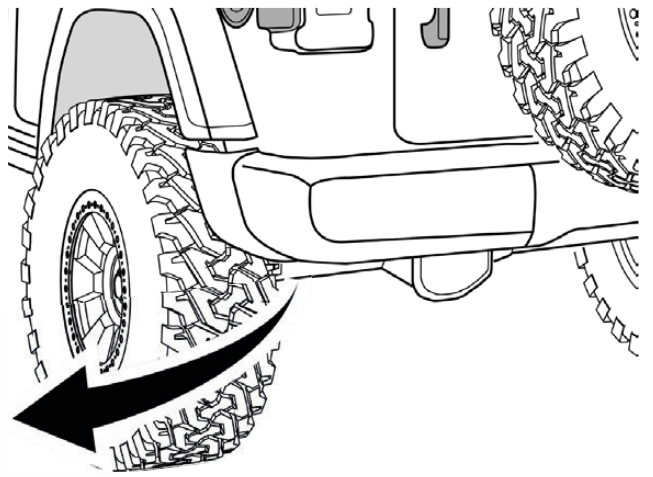

REMOVE THE REAR SHOCKS

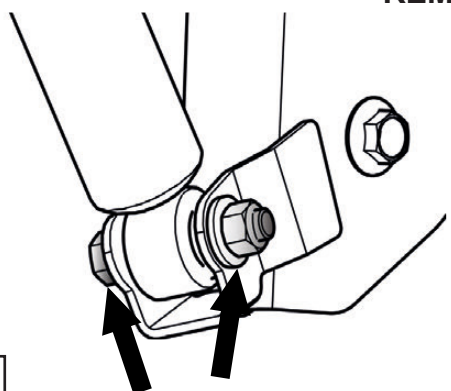

2X
31

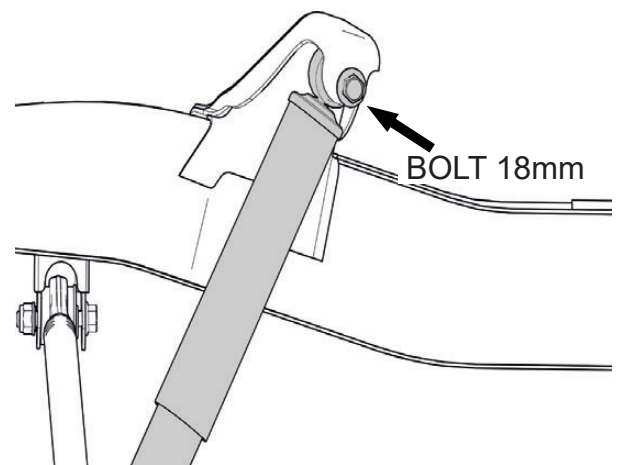

LOWER AXLE TO REMOVE & DISCARD REAR SPRINGS

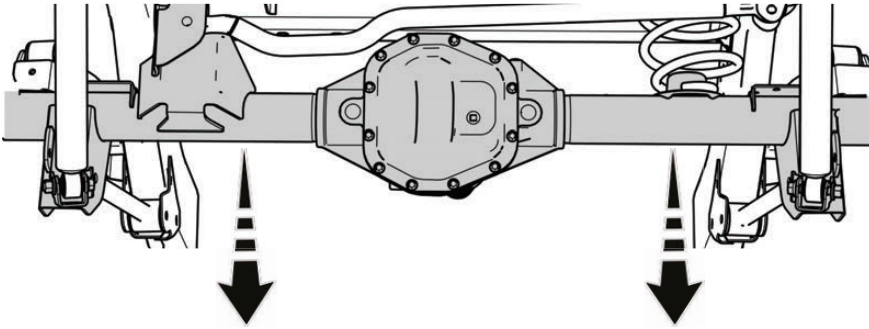

2X

32

NOTE: REMOVE ANY PLASTIC RETAINERS FROM WIRING OR HOSES AS NEEDED.

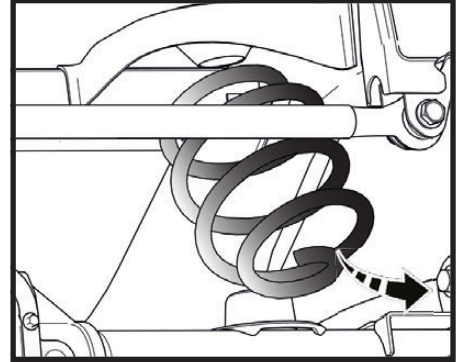

INSTALL NEW REAR SPRINGS

INSTALL THE DRIVERS SIDE SPRING FIRST

LEFT REAR SPRINGS
4 DOOR: 02-22-411-250-1
2 DOOR: 02-22-211-250-1

NOTE: PAY SPECIAL ATTENTION TO INSTALL THE CORRECT SPRING ON THE CORRECT SIDE OF THE JEEP. THE REAR SPRINGS ARE SIDE SPECIFIC.

33

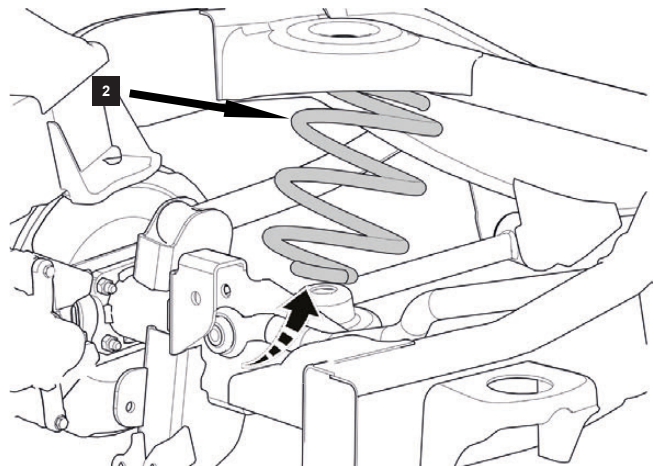

INSTALL THE PASSENGERS SIDE SPRING

RIGHT REAR SPRINGS
4 DOOR: 02-22-421-250-1
2 DOOR: 02-22-221-250-1

2X

34

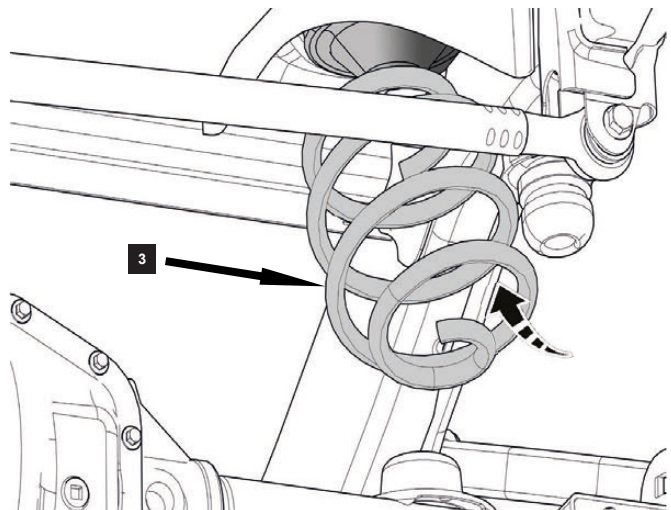

RAISE THE REAR AXLE AND INSTALL SHOCKS

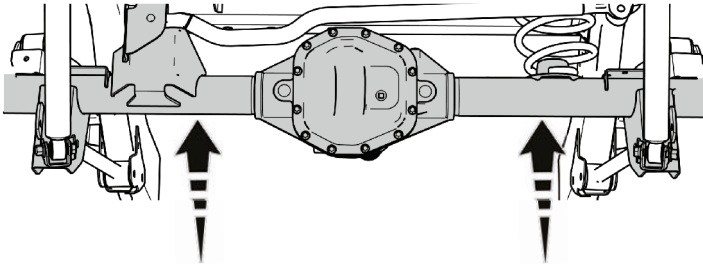

MAKE SURE TO FULLY SEAT THE SPRINGS INTO THE UPPER SPRING ISOLATOR

35

INSTALL REAR FALCON SHOCKS AT THIS TIME

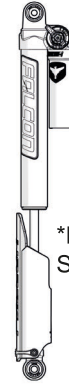

*Refer to the Quick Start Guide.

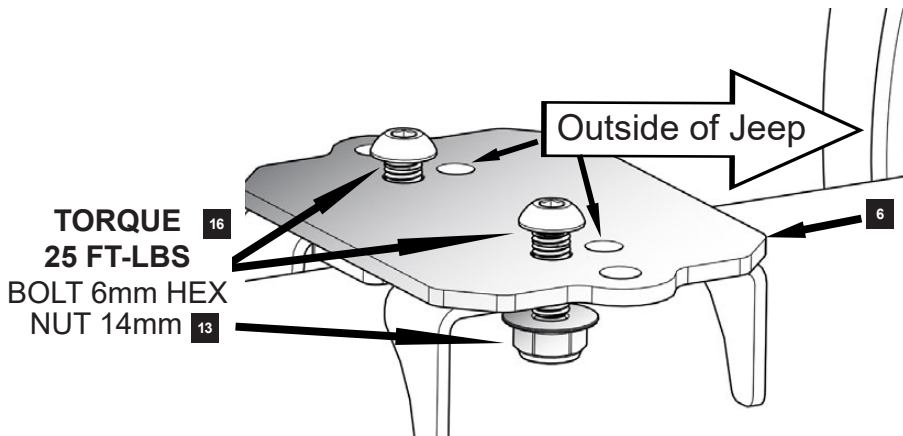

TORQUE 25 FT-LBS

**BOLT 6mm HEX
NUT 14mm**

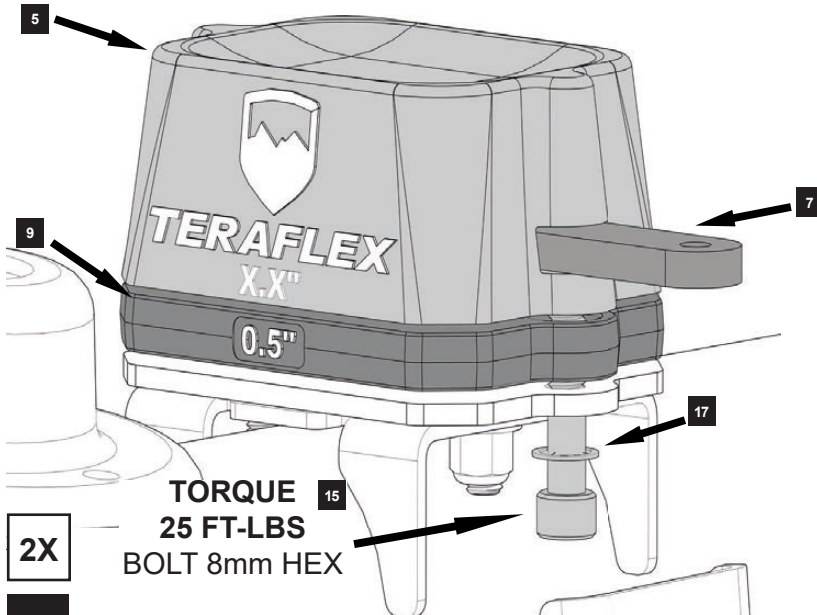

**TORQUE 25 FT-LBS
BOLT 8mm HEX**

2X

36

NOTE: REFER TO PAGE 19 FOR BUMPSTOP SPACER GUIDE

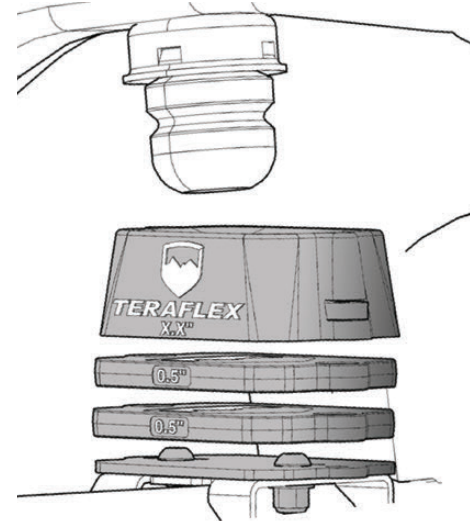

REINSTALL BRAKE LINE BRACKETS

RECONNECT PLASTIC RETAINERS FROM WIRING OR HOSES AS NEEDED

REINSTALL BOLT 13mm

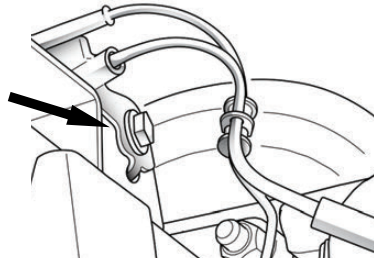

2X

NOTE: DO NOT TIGHTEN THE CONTROL ARM BOLTS UNTIL THE JEEP IS ON THE GROUND

37

INSTALL NEW SWAY BAR LINKS

TORQUE
45 FT-LBS
NUT 19 mm
BOLT 8mm
HEX KEY

2X

38

TORQUE
66 FT-LBS
NUT 19mm
STUD 6mm
HEX KEY

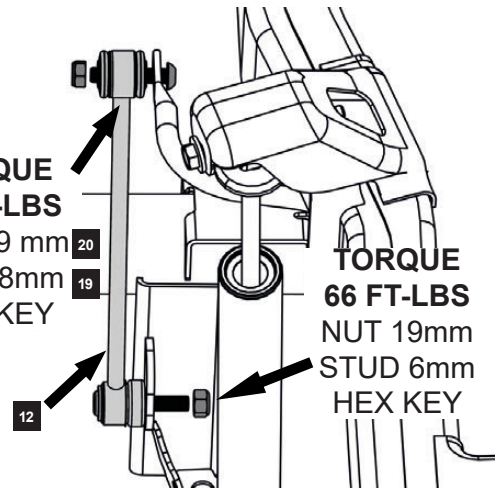

SLIDE THE FRONT TRACK BAR BRACKET INTO PLACE AND MARK THE FRONT AND REAR HOLES THAT NEED TO BE DRILLED. ONCE MARKED REMOVE THE BRACKET AND DRILL THE HOLES.

39

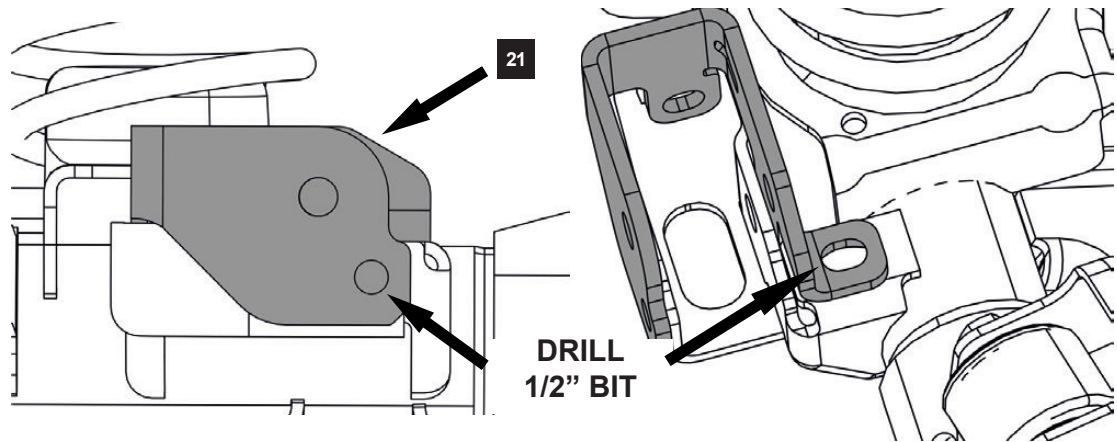

INSTALL ONE OF THE M12 BOLTS AND THE PROVIDED SERRATED NUT THROUGH THE BOTTOM. THREAD THE NUT ONTO THE BOLT FINGER TIGHT.

40

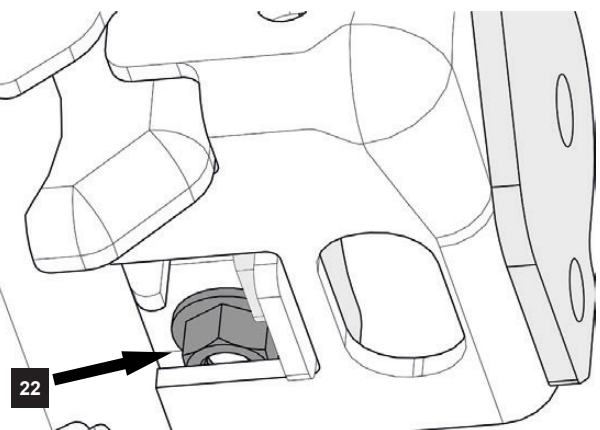
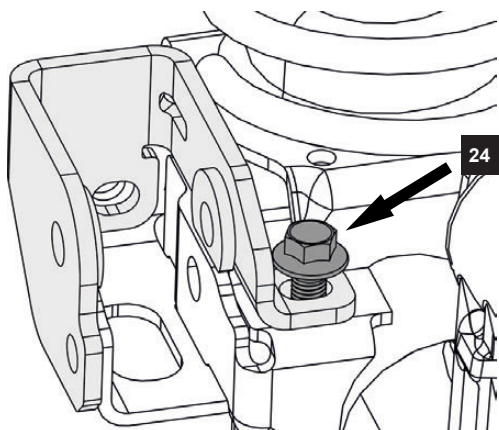

INSTALL THE OTHER M12 BOLT AND NUT. LEAVE LOOSE

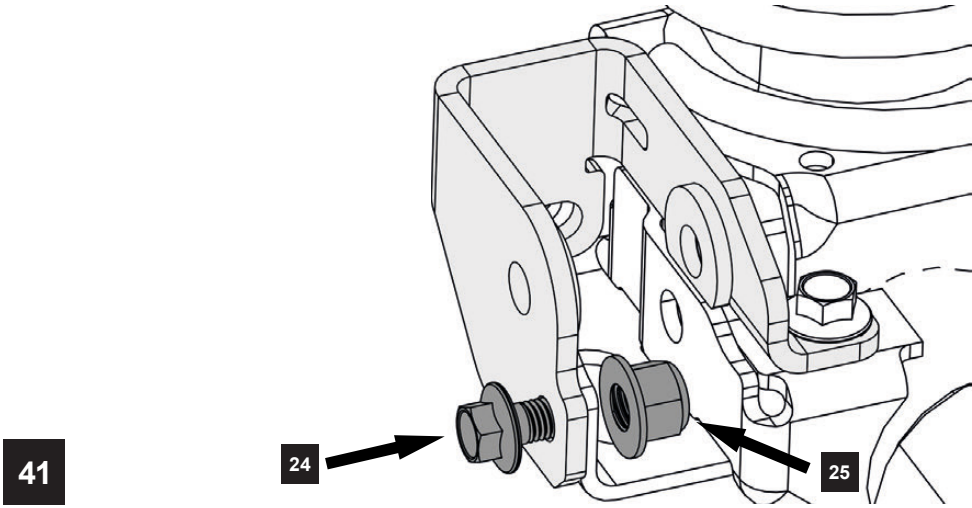

41

REINSTALL THE SWAYBAR LINK USING THE FACTORY HARDWARE AND TIGHTEN FIRST THEN TIGHTEN THE OTHER BOLTS AND TORQUE.

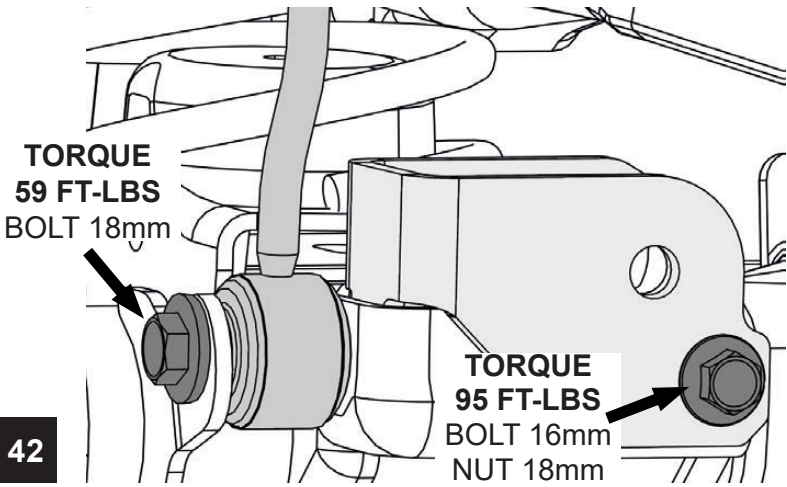

42

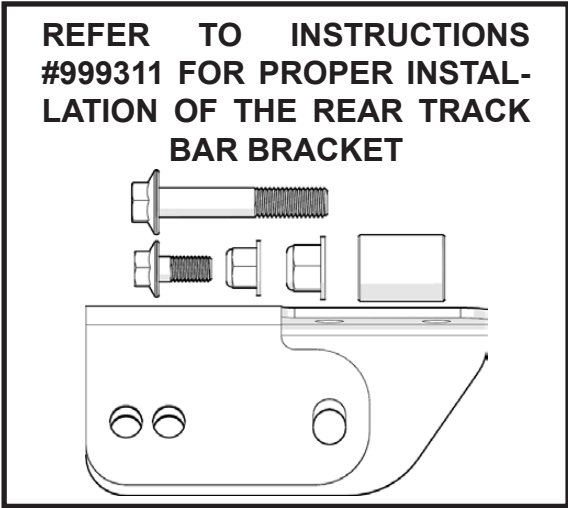
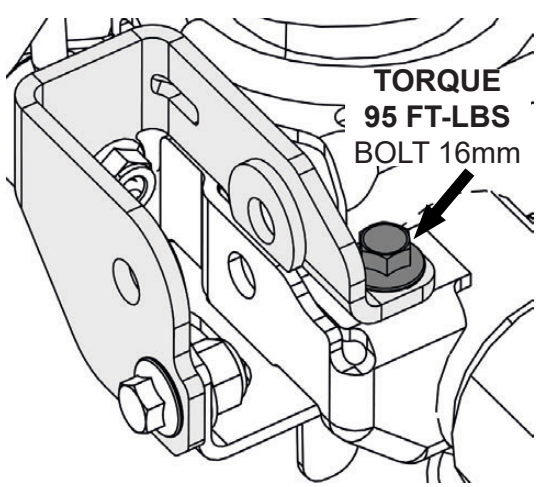

43

REINSTALL TIRES AND LOWER TO THE GROUND

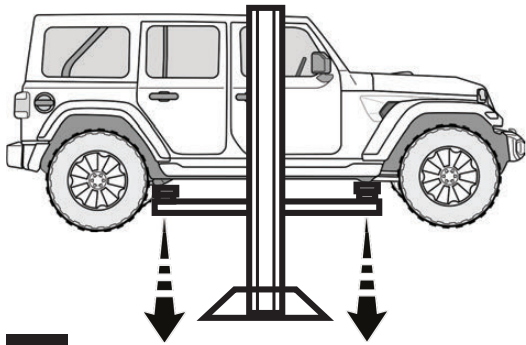

44

TORQUE TO 130 FT LBS

REINSTALL THE REAR TRACK BAR INTO THE NEW BRACKET AND TORQUE TO THE FOLLOWING SPECS

TORQUE REAR

BOLT 21mm
74 Ft Lbs + 60°

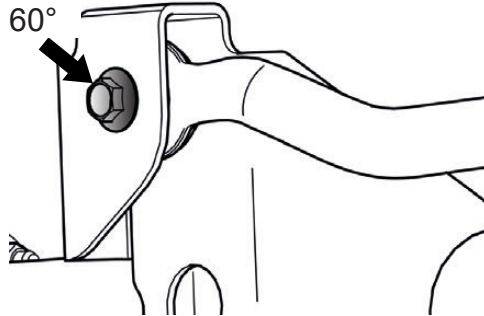

45

REINSTALL THE FRONT TRACK BAR USING THE SUPPLIED HARDWARE

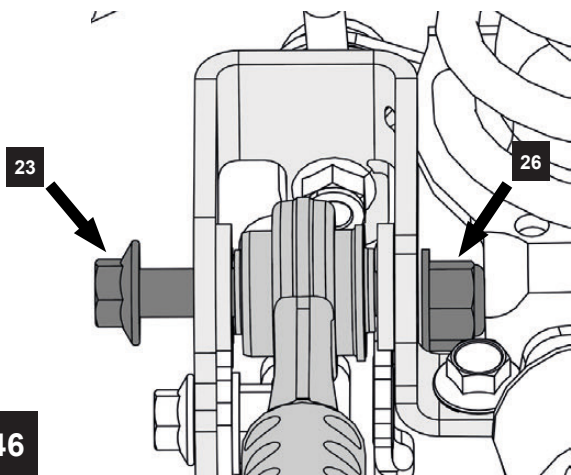

46

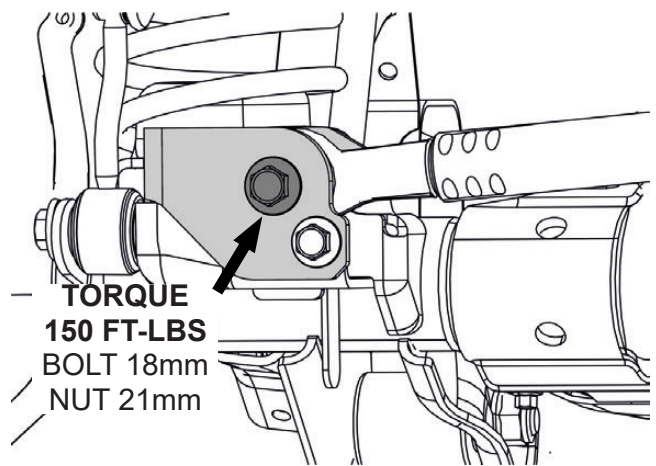

TORQUE
150 FT-LBS
BOLT 18mm
NUT 21mm

TORQUE CONTROL ARMS

REAR

TORQUE 21mm
74Ft Lbs + 65°

TORQUE 21mm
74Ft Lbs + 80°

FRONT

TORQUE 18mm
41Ft Lbs + 185°

TORQUE 18mm
37 Ft Lbs +135°

2X

47

TORQUE 21mm
74Ft Lbs + 50°

TORQUE
103 Ft Lbs +145°
BOLT 21mm
NUT 24mm

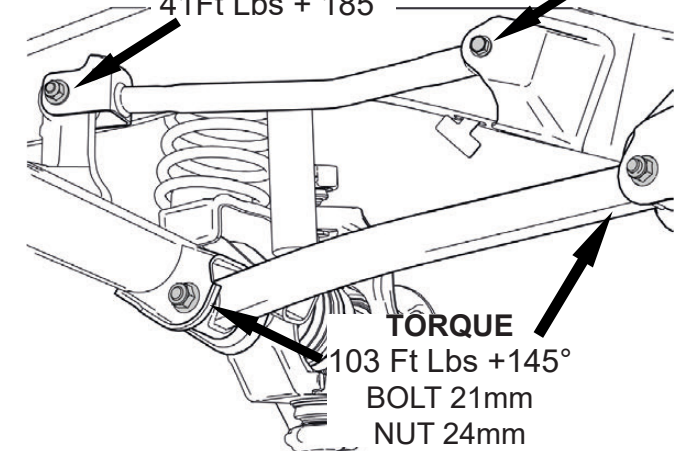
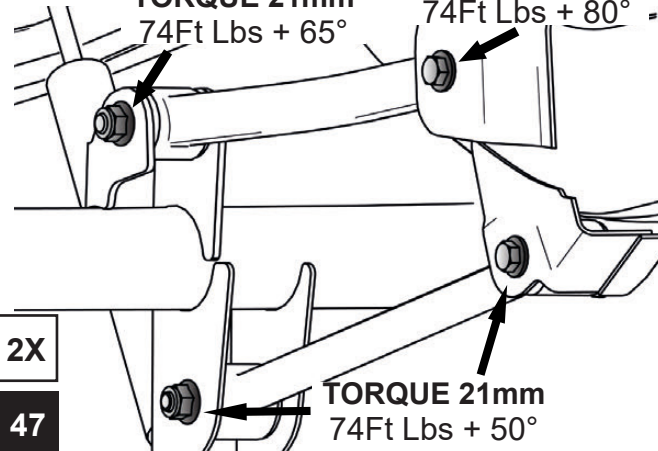

JL Tire Clearance Guide (FACTORY FENDERS)

By limiting suspension up travel, TeraFlex Bump Stops allow the use of larger tires while keeping the factory fenders.

JL Rubicon models feature high-clearance fenders that allow for more up travel, while the lower-clearance fenders on JL Sport and Sahara restricts tire size due to fender rubbing.

In order to address these fender differences, TeraFlex designed a proprietary modular bump stop system, which can be adapted to fit several different lift height and tire size configurations.

In addition to the main 2" bump stop spacers, this system includes multiple 0.5" interlocking spacers that can be added to fine tune bump stop height to limit suspension up travel.

JL RUBICON

JL Rubicon with Factory Fenders:

See Notes: Not all Tires Measure the Same

- 33" - No Bump Stops
- 35" - 2" Front & 2" Rear Bump Stops



- 37" - 2.5" Front & 3" Rear Bump Stops

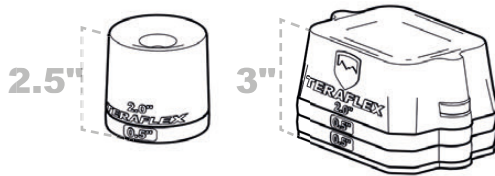

JL SPORT/SAHARA

JL Sport/Sahara with Factory Fenders:

See Notes: Not all Tires Measure the Same

- 33" - No Bump Stops
- 35" - 3" Front & 2.5" Rear Bump Stops

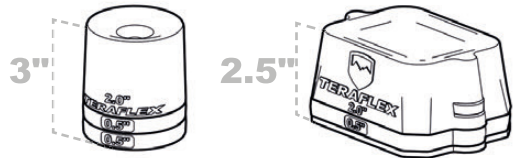

- 37" - 3.5" Front & 4" Rear Bump Stops

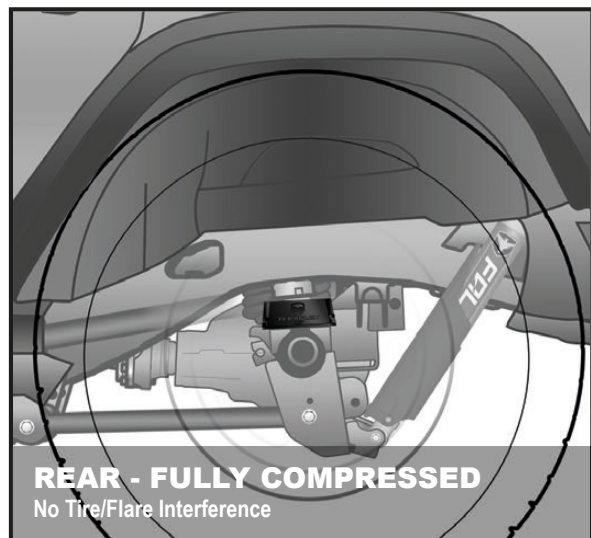
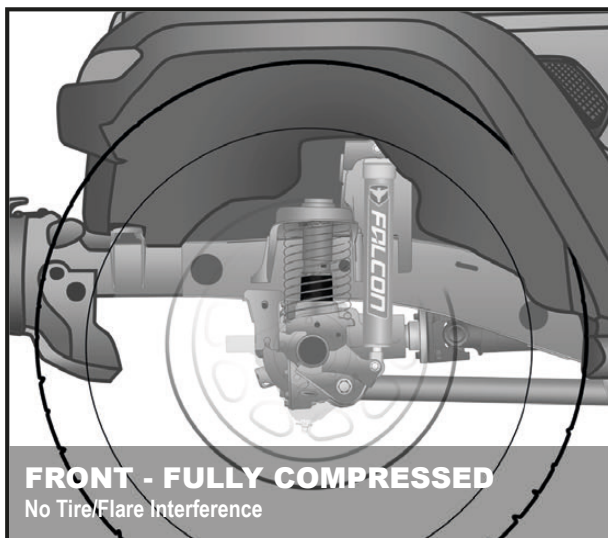
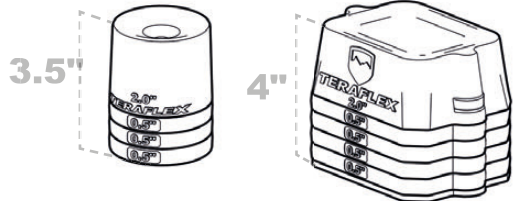

2-4 Inch Shock Options

JL Falcon Adjustable PiggyBack Shocks

- 4 Door Series 3.3, 11-01-33-400-200-3
- 2 Door Series 3.3, 10-01-33-400-200-3

- *Fast Adjust Knob
- *High Flow Oil Channel
- *Offset Sleeve Design
- *PiggyBack Reservoir

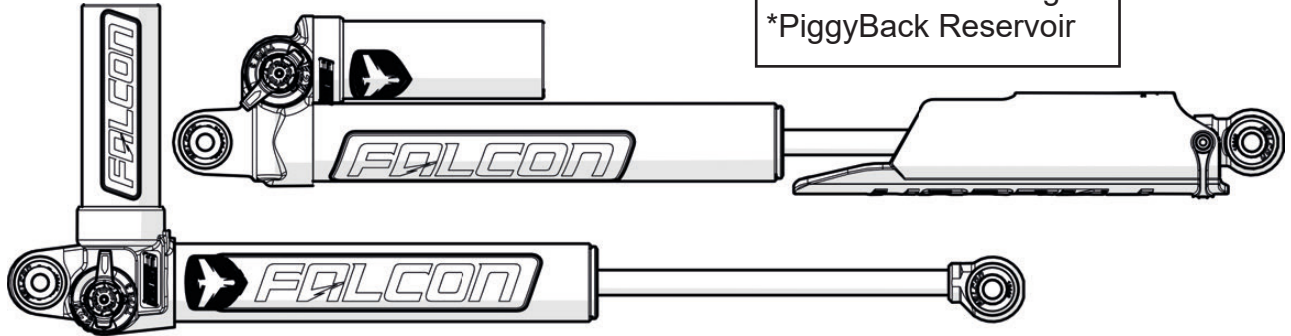

JL Falcon PiggyBack Shocks

- 4 Door Series 3.1, 11-01-31-400-200-3
- 2 Door Series 3.1, 10-01-31-400-200-3

- *Series 3.3 Upgradable
- *High Flow Oil Channel
- *Offset Sleeve Design
- *PiggyBack Reservoir

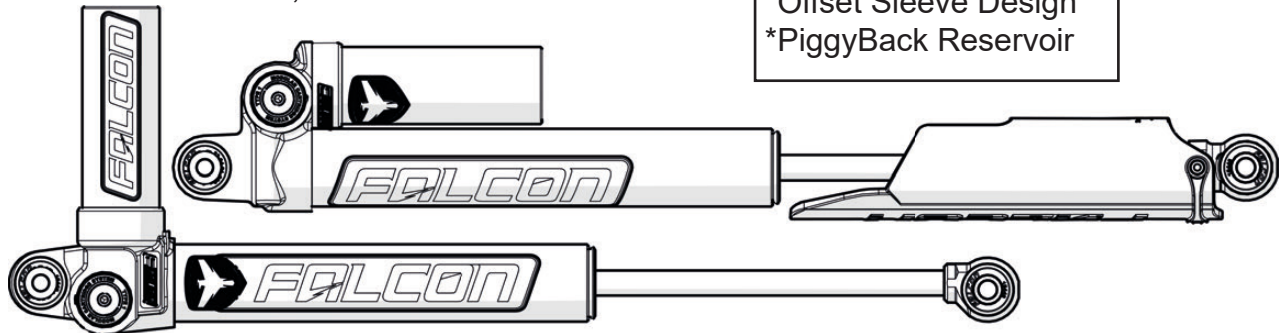

JL Falcon Monotube Shocks

- 4 Door Series 2.1, 11-01-21-400-200-3
- 2 Door Series 2.1, 10-01-21-400-200-3

- *Oil Gas Separator
- *3/4" Chrome Shaft
- *Offset Sleeve Design
- *JL Specific Shock

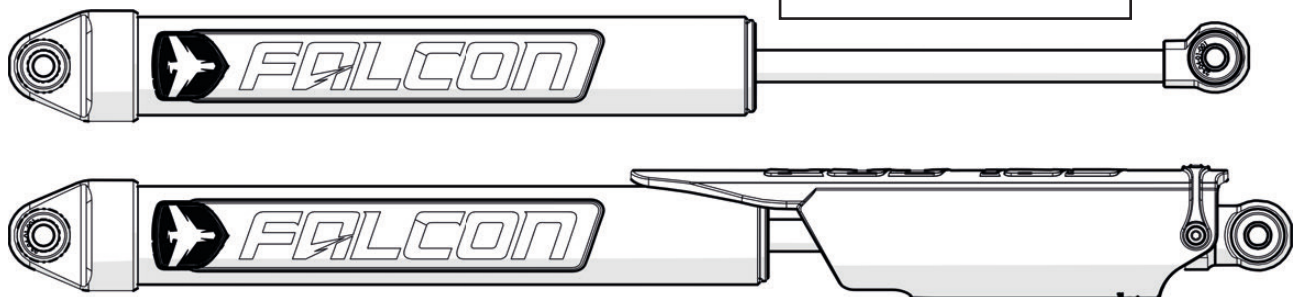



Jeep JL Wrangler Jounce Bumper Instructions

Kit #1959200 - Jounce Bumper Kit, Jeep JL Wrangler



1



2

Item No.	Part Number	Description	Qty
1	45-02-02-002	Bumper (S), Foam, Snap-In, 3.90" Tall	2
2	45-02-03-001	Bumper (S), Foam, Snap-In / 1.97" Dia. 4.72" Tall	2

Important Notes:

Prior to beginning this install, or any installation, *read the instructions thoroughly* to familiarize yourself with the required steps. Evaluate if you are experienced and capable to personally perform these modifications. A factory service manual should be used in conjunction with these installation instructions.

After altering the suspension it is always advisable to have an alignment done by a competent 4 wheel drive shop or by an alignment shop that is experienced with lifted 4 wheel drive vehicles.

Refer to the parts list to ensure that all necessary components and hardware has been included. If any parts are missing please contact your local TeraFlex dealer for assistance.

Refer to the factory service manual for the torque specs of the originally equipped hardware.

Tools needed:

- This installation guide
- Basic mechanics tool set

FRONT AXLE

REFER TO THE FACTORY SERVICE MANUAL FOR LIFT LOCATIONS.

1. Raise and support the vehicle at the frame.
2. Remove the front tires and wheels.
3. Support the front axle with a jack or jack stands.
4. Remove the sway bar links at the axle.
5. Remove the track bar at the axle.

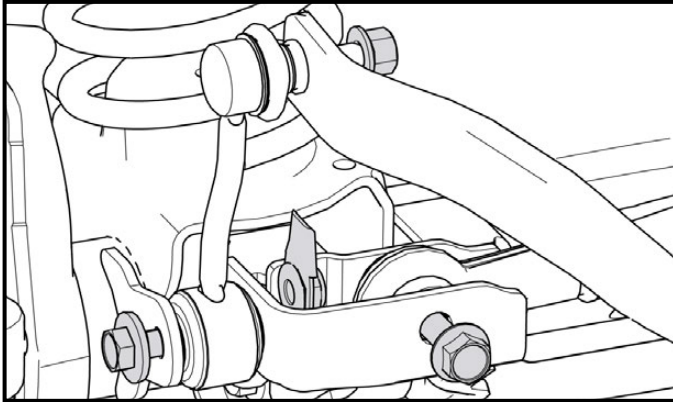

6. Remove the ABS/brake line anchor bracket from the frame (driver and passenger side).
7. Remove the breather hose and axle actuator from the axle. **NOTE:** On Rubicon models the locker actuator will need to be removed as well.

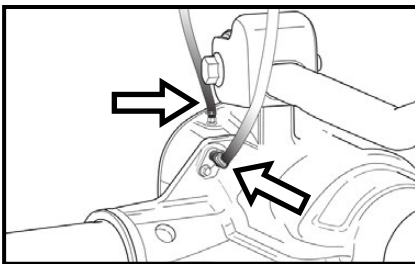
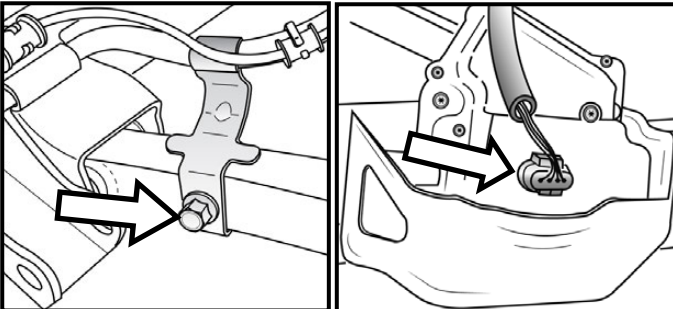

8. Remove the shock at the axle.
10. Lower the axle until the springs are free and remove the springs. **NOTE:** Watch brake lines and wiring harnesses while lowering axle.

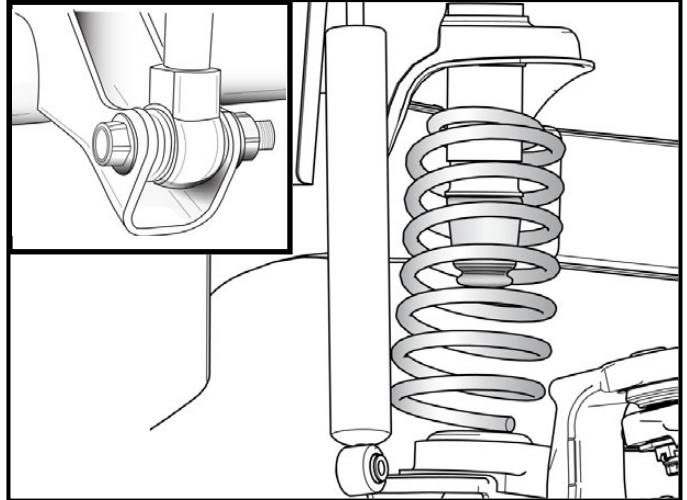

10. Remove the front bumpstops.
11. Install the new Front Extended Bumpstops into the factory jounce tubes. **Note:** If needed use a small amount of silicone lube spray, to help install the bumpstops.

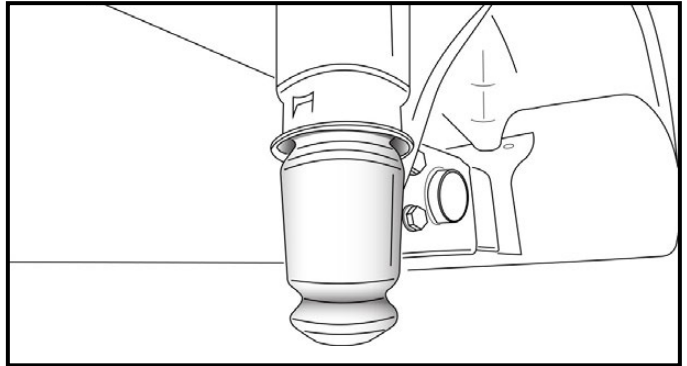

12. Reinstall the springs. **NOTE:** Check that the upper spring isolator is installed correctly with the locating pins aligned with holes in the upper spring mount.
13. Rotate the spring until pig tail end is fully seated into lower spring pads.
14. Raise the axle enough to reinstall the shocks. Torque shock bolts to 56 ft-lbs.
15. Reinstall sway bar links and torque bolts to 69 ft-lbs.

16. Reinstall brake line brackets, axle actuator plug and breather hose and any plastic retainers from wiring or hoses that were removed.
Rubicon models: Reinstall locker actuator plug.
17. Reinstall the front wheels and tires and lower Jeep to the ground. Torque lug nuts to factory recommended specs.
18. Reinstall the front track bar and torque bolt to factory recommended specs.

REAR AXLE

19. Remove the bumpstop from the frame mount by simply pulling downward with a twisting motion.

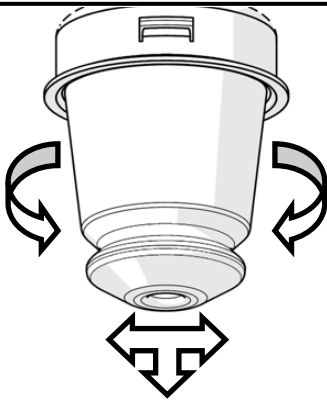

20. Install new bumpstop by twisting and pushing up. Note: If needed use a small amount of silicone lube spray, to help install the bumpstops.

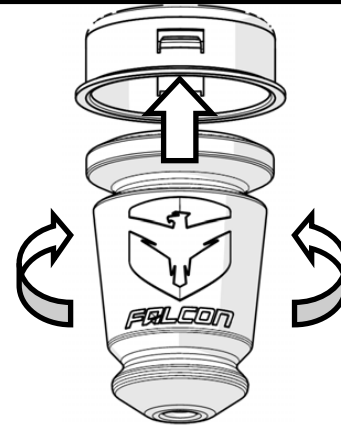

**CONFIRM THAT ALL BRACKETS
ARE REINSTALLED AND FASTENERS
TORQUED CORRECTLY BEFORE
OPERATING THE JEEP.**

INSTALLATION IS COMPLETE!



JL ALPINE SHORT CONTROL ARMS

1416610

1416510

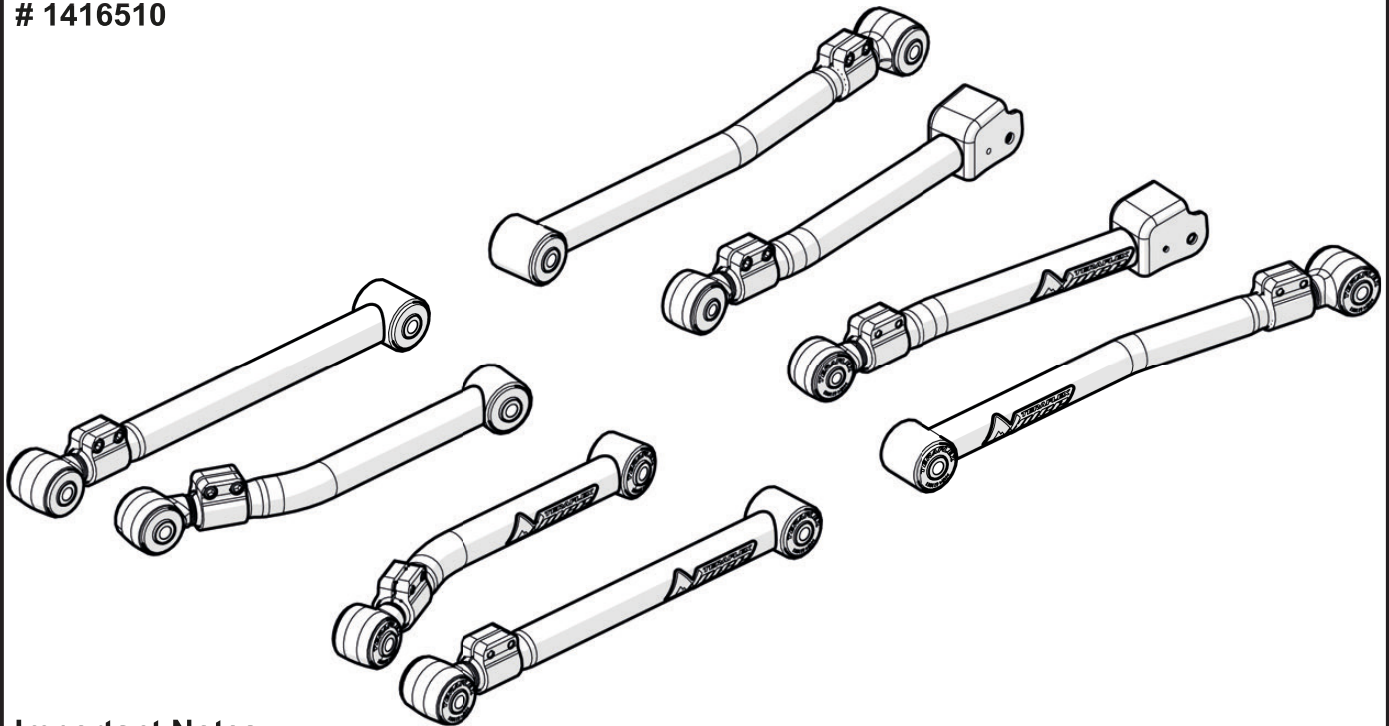

Important Notes:

Prior to beginning this install, or any installation, read the instructions thoroughly to familiarize yourself with the required steps. Evaluate if you are experienced and capable to personally perform these modifications. A factory service manual should be used in conjunction with these installation instructions.

This product will change the highway handling characteristics of your vehicle, exercise caution. After altering the suspension it is always advisable to have an alignment done by a competent 4 wheel drive shop or by an alignment shop that is experienced with lifted 4 wheel drive vehicles.

Refer to the parts list to ensure that all necessary components and hardware has been included. If any parts are missing please contact your local TeraFlex dealer for assistance.

When reinstalling OEM hardware, refer to the torque specs given in the Factory Service Manual.

Tools Needed:

- Metric Sockets and Open End Wrenches
- Torque Wrench

- Factory Service Manual
- General Mechanics Tools

Maintenance Note:

After the first 300 miles and every 3,000 miles after that, re-torque all the suspension components and bolts.

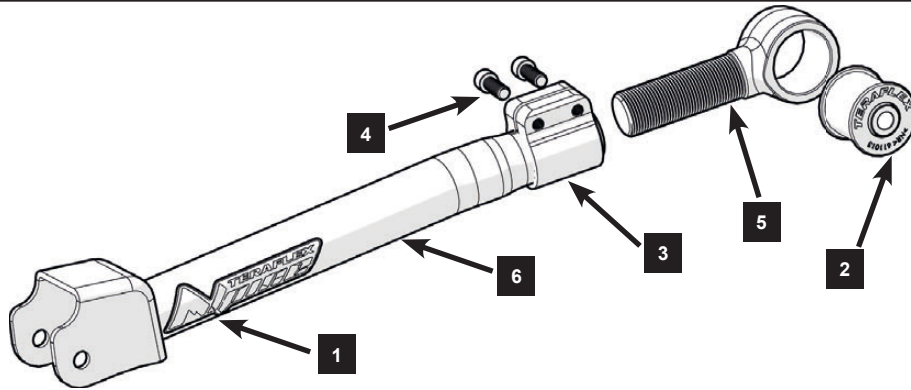

Front Upper HD Adjustable Control Arms			
Item #	Part No.	Description	QTY
1	95-01-003-001	Sticker, Teraflex, Alpine Arm, Polycarbonate	1
2	611014	Front Upper JL Control Arm Bushing Factory Replacement	1
3	107105	Alpine Control Arm Aluminum Clamp	1
4	414	3/8"-16x1" Socket Head Cap Screw	2
5	116110	JL Front Upper Forged Bushing Eyelet	1
6	07-01-001-005	Control Arm, Alpine / Jeep JL, Front / Upper / Left Assembly	1
	07-01-001-006	Control Arm, Alpine / Jeep JL, Front / Upper / Right Assembly	
Alpine IR Bushings			
1	36-01-002-001	IR Badge, Teraflex	1
	95-01-004-001	Sticker, Teraflex, Alpine IR Arm, Polycarbonate	
2	611017	IR Revolver Rubber Bushing, Front Upper Arm	1

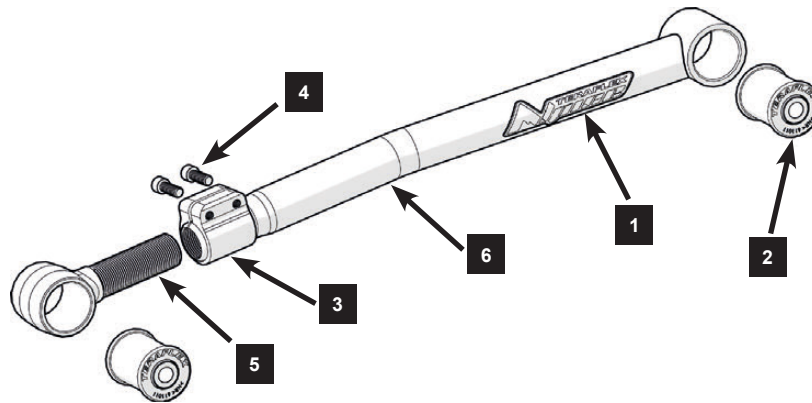

Front Lower HD Adjustable Control Arms			
Item #	Part No.	Description	QTY
1	95-01-003-001	Sticker, Teraflex, Alpine Arm, Polycarbonate	1
2	09-01-201-001	Front Lower JL Control Arm Bushing Factory Replacement	2
3	107105	Alpine Control Arm Aluminum Clamp	1
4	414	3/8"-16x1" Socket Head Cap Screw	2
5	116110	JL Front Upper Forged Bushing Eyelet	1
6	07-01-001-001	Control Arm, Alpine / Jeep JL, Front / Lower / Left Assembly	1
	07-01-001-002	Control Arm, Alpine / Jeep JL, Front / Lower / Right Assembly	
Alpine IR Bushings			
1	36-01-002-001	IR Badge, Teraflex	1
	95-01-004-001	Sticker, Teraflex, Alpine IR Arm, Polycarbonate	
2	611020	IR Rubber Bushing, Lower Control Arm	2

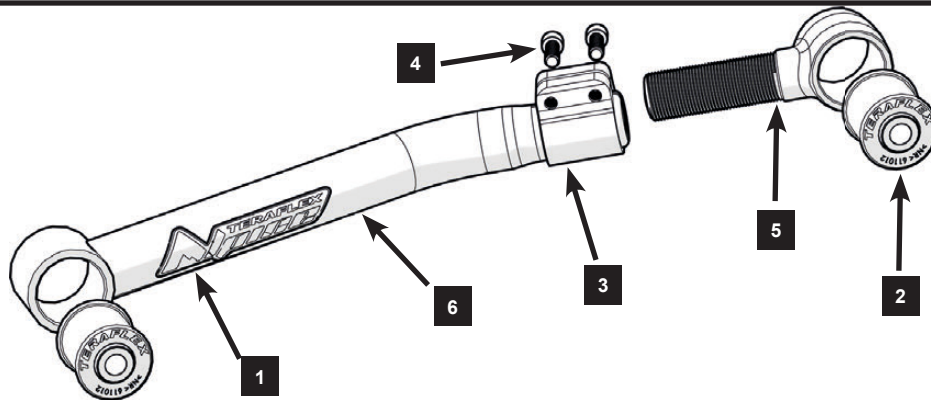

Rear Upper HD Adjustable Control Arms			
Item #	Part No.	Description	QTY
1	95-01-003-001	Sticker, Teraflex, Alpine Arm, Polycarbonate	1
2	611012	Rear Upper JL Control Arm Bushing	2
3	107105	Alpine Control Arm Aluminum Clamp	1
4	414	3/8"-16x1" Socket Head Cap Screw	2
5	116130	JL Front Upper Forged Bushing Eyelet	1
6	07-01-001-011	Control Arm, Alpine / Jeep JL , Rear / Upper / Left Assembly	1
	07-01-001-012	Control Arm, Alpine / Jeep JL, Rear / Upper / Right Assembly	
Alpine IR Bushings			
1	36-01-002-001	IR Badge, Teraflex	1
	95-01-004-001	Sticker, Teraflex, Alpine IR Arm, Polycarbonate	1
2	611016	IR Revolver Rubber Bushing, Rear Upper Arm	2

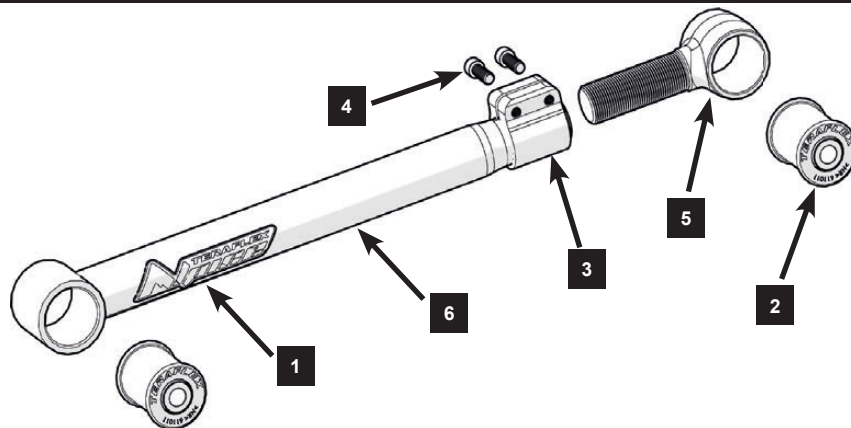

Rear Lower HD Adjustable Control Arms			
Item #	Part No.	Description	QTY
1	95-01-003-001	Sticker, Teraflex, Alpine Arm, Polycarbonate	1
2	611011	JL / JK Lower Control Arm Bushing	2
3	107105	Alpine Control Arm Aluminum Clamp	1
4	414	3/8"-16x1" Socket Head Cap Screw	2
5	116110	JL / JK Rear Lower Forged Bushing Eyelet	1
6	141542	Alpine JL / JK Rear Lower Driver HD Adjustable Control Arm	1
	141552	Alpine JL / JK Rear Lower Passenger HD Adjustable Control Arm	
Alpine IR Bushings			
1	36-01-002-001	IR Badge, Teraflex	1
	95-01-004-001	Sticker, Teraflex, Alpine IR Arm, Polycarbonate	1
2	611015	IR Revolver Rubber Bushing, Rear Lower Arm	2

INSTALLATION OF THE CONTROL ARMS IS BEST DONE WITH ALL 4 TIRES OF THE JEEP ON THE GROUND. IF YOU PREFER TO RAISE THE JEEP FOR INSTALLATION REFER TO YOUR FACTORY SERVICE MANUAL FOR SAFE LIFTING LOCATIONS AND PROCEDURES.

NOTE: DO NOT REMOVE MORE THAN TWO CONTROL ARMS AT A TIME

FRONT LOWER CONTROL ARMS

NOTE: THE FRONT LOWER SHOCK BOLTS ARE SLIGHTLY TOO LONG AND WILL MAKE CONTACT WITH THE ALPINE CONTROL ARMS. TO FIX THIS ISSUE SWAP THE LOWER SHOCK BOLTS WITH THE LOWER SWAY BAR LINK BOLTS.

REMOVE THE SWAY BAR LINK BOLTS AT THE AXLE

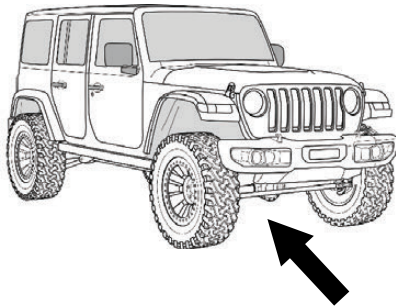

1

BOLT
18mm

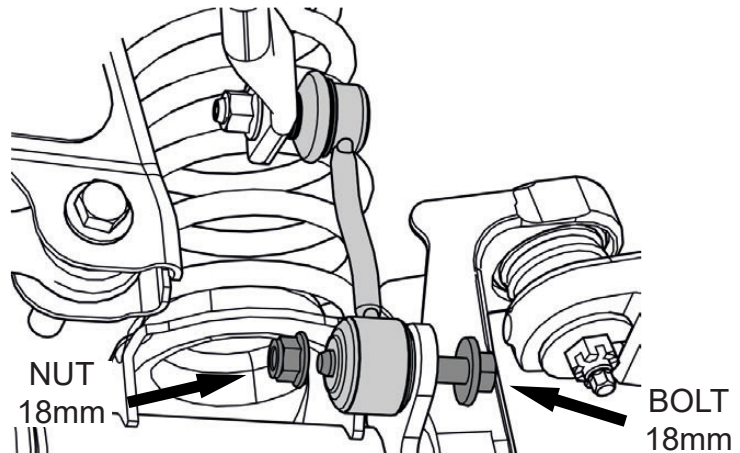
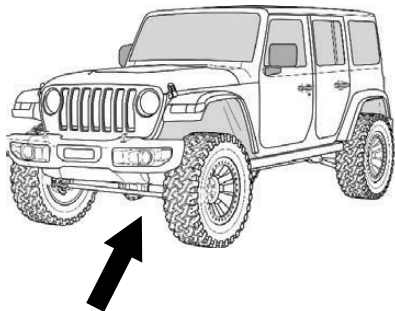
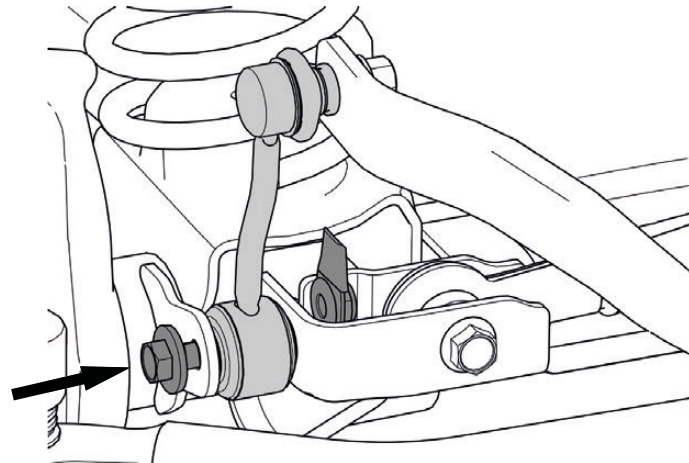

REMOVE THE FRONT LOWER SHOCK BOLTS AND REPLACE WITH THE LOWER SWAY BAR LINK BOLTS

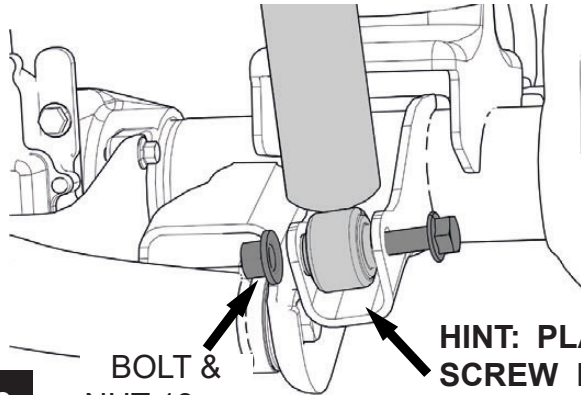

2

**BOLT &
NUT 18mm**

**HINT: PLACE A PRY BAR OR
SCREW DRIVER UNDER THE
SHOCK TO HELP SWAP BOLTS**

**ONCE THE BOLTS HAVE BEEN
SWAPPED TORQUE THE SWAY
BAR LINK BOLTS TO 59 FT-LBS
AND THE LOWER SHOCK BOLTS
TO 74 FT-LBS**

REMOVE THE FRAME SIDE LOWER CONTROL ARM BOLT

**REMOVE AND DISCARD THE
BRAKE LINE BRACKETS FROM
THE CONTROL ARMS AND BRAKE
LINES**

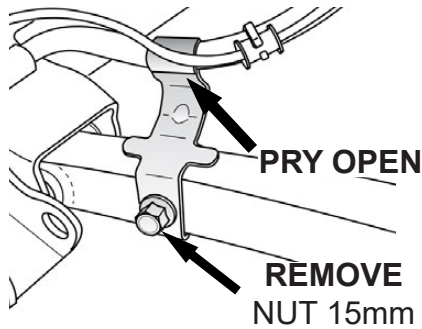

3

**REMOVE
NUT 15mm**

PRY OPEN

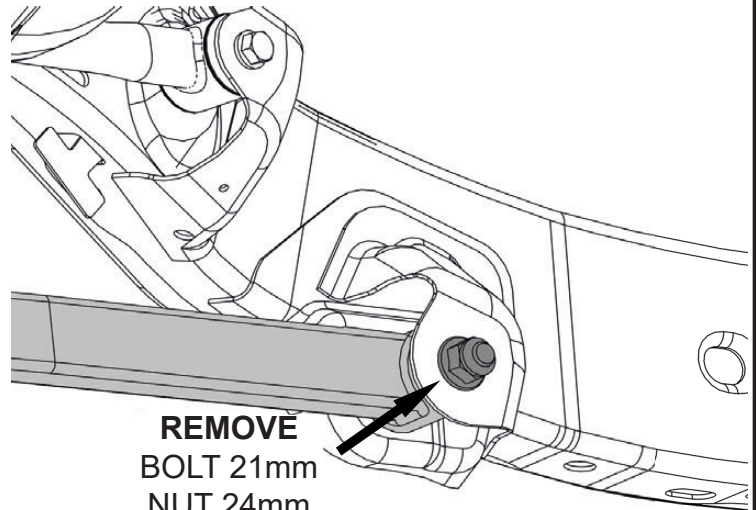

**REMOVE
BOLT 21mm
NUT 24mm**

REMOVE THE AXLE SIDE LOWER CONTROL ARM BOLT

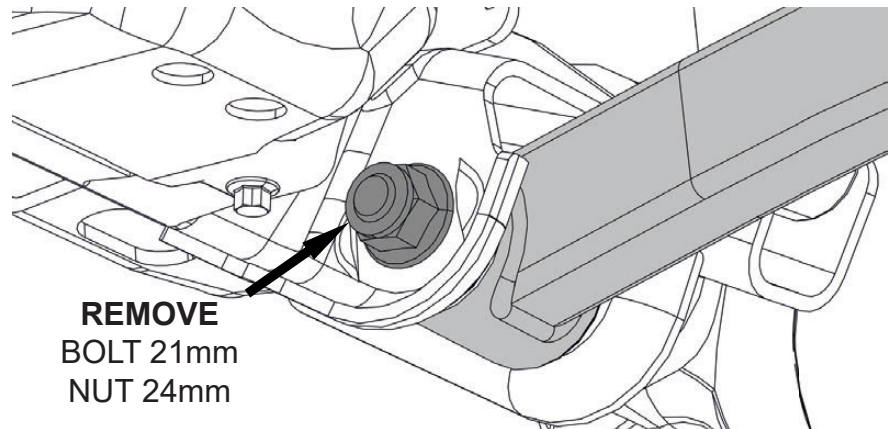

**REMOVE
BOLT 21mm
NUT 24mm**

4

INSTALL THE FIXED END OF THE ALPINE CONTROL ARM TO THE FRAME WITH THE STICKER FACING OUT. LEAVE FINGER TIGHT.

DO NOT TORQUE THE CONTROL ARMS TIGHT UNTIL THE END OF THE INSTALLATION.

TORQUE
BOLT 21mm
NUT 24mm
103 Ft Lbs + 145°

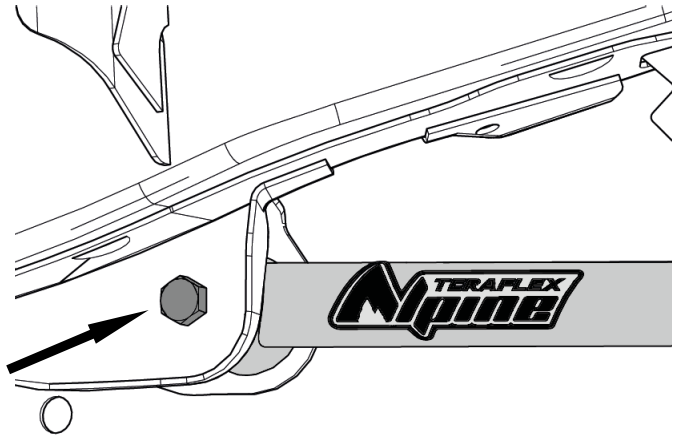

5

LOOSEN THE CLAMP AND EXTEND THE CONTROL ARM TO THE RECOMMENDED LENGTH. INSTALL THE CONTROL ARM INTO THE AXLE MOUNT.

REFER TO PAGE 11 FOR RECOMMENDED CONTROL ARM LENGTHS.

DO NOT TORQUE THE CONTROL ARMS TIGHT UNTIL THE END OF THE INSTALLATION.

TORQUE
BOLT 21mm
NUT 24mm
103 Ft Lbs + 145°

TORQUE 8mm
30 FT Lbs

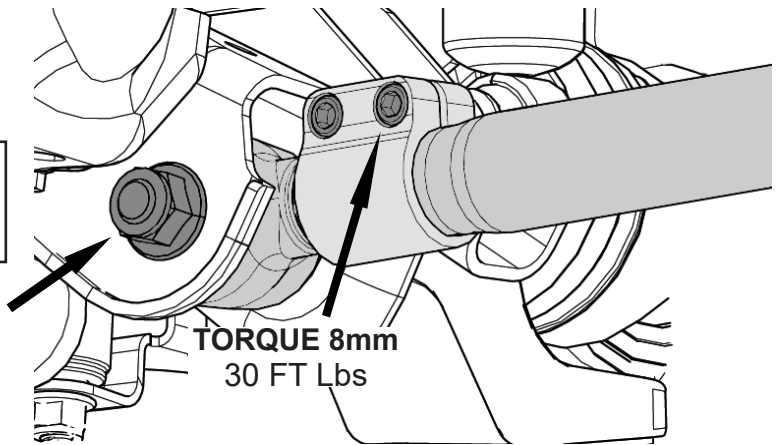

6

FRONT UPPER CONTROL ARMS

REMOVE THE FRAME SIDE UPPER CONTROL ARM HEAT SHEILD AND BOLT

REMOVE
BOLT 18mm

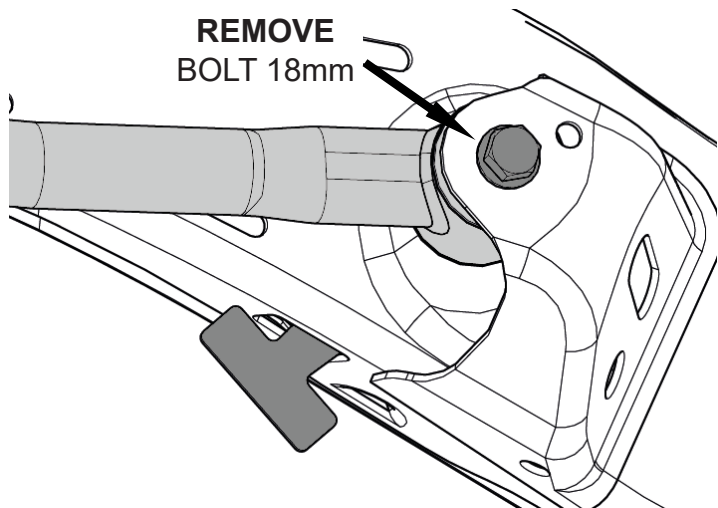

7

REMOVE THE AXLE SIDE UPPER CONTROL ARM BOLT

**REMOVE
BOLT 18mm
NUT 18mm**

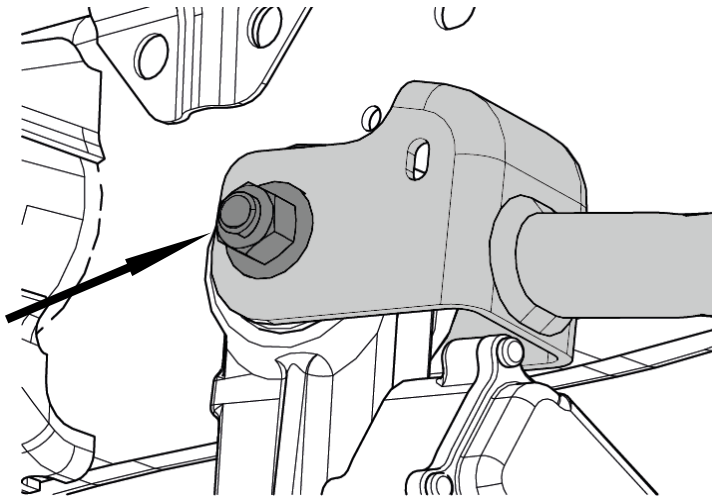

8

INSTALL THE FIXED END OF THE ALPINE CONTROL ARM TO THE AXLE WITH THE STICKER FACING OUT. LEAVE FINGER TIGHT.

DO NOT TORQUE THE CONTROL ARMS TIGHT UNTIL THE END OF THE INSTALLATION.

**TORQUE 18mm
41Ft Lbs + 185°**

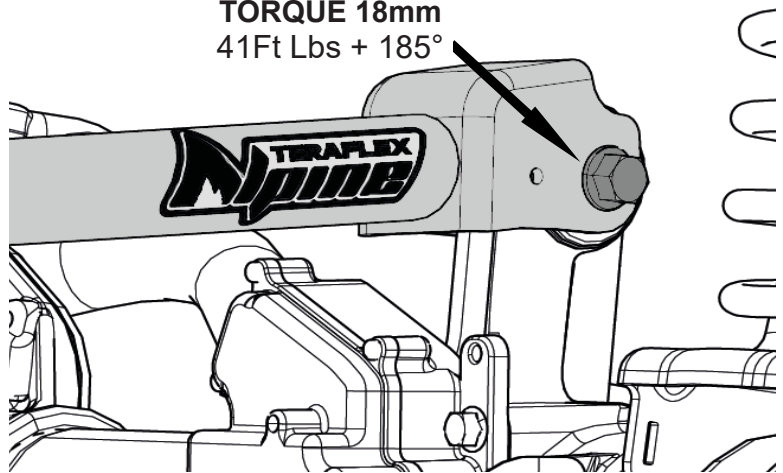

9

LOOSEN THE CLAMP AND EXTEND THE CONTROL ARM TO THE RECOMMENDED LENGTH. INSTALL THE CONTROL ARM INTO THE FRAME MOUNT WITH THE HEAT SHIELD.

**REFER TO PAGE 11 FOR
RECOMMENDED CONTROL
ARM LENGTHS.**

DO NOT TORQUE THE CONTROL ARMS TIGHT UNTIL THE END OF THE INSTALLATION.

**TORQUE 18mm
37 Ft Lbs +135°**

**TORQUE 8mm
30 FT Lbs**

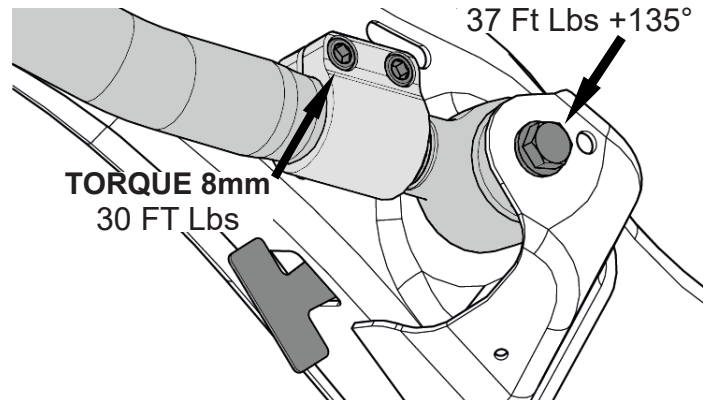

10

REAR LOWER CONTROL ARMS

REMOVE THE FRAME SIDE LOWER CONTROL ARM BOLT

11

REMOVE
BOLT 21mm
NUT 21mm

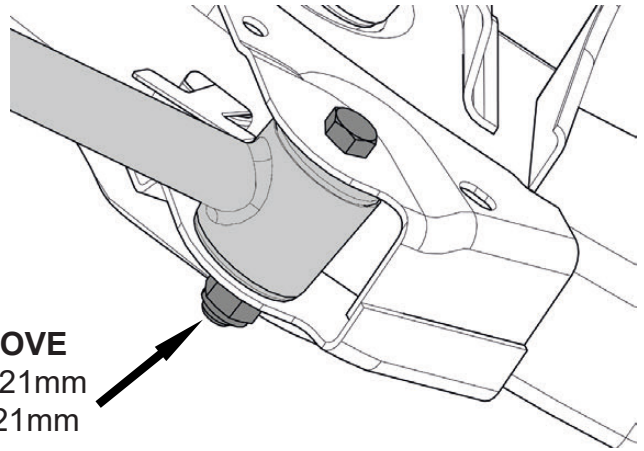

REMOVE THE AXLE SIDE LOWER CONTROL ARM BOLT

12

REMOVE
BOLT 21mm
NUT 21mm

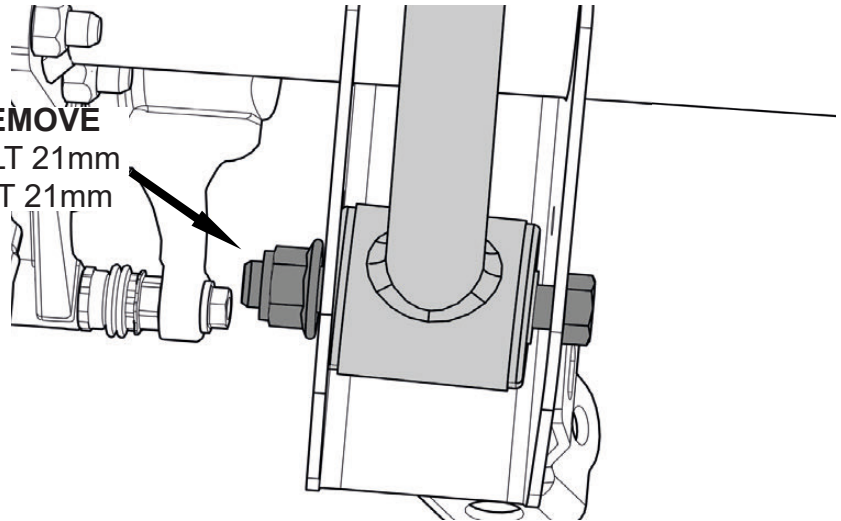

INSTALL THE FIXED END OF THE ALPINE CONTROL ARM TO THE FRAME WITH THE STICKER FACING OUT. LEAVE FINGER TIGHT.

DO NOT TORQUE THE CONTROL ARMS TIGHT UNTIL THE END OF THE INSTALLATION.

TORQUE
BOLT 21mm
NUT 21mm
74Ft Lbs + 50°

13

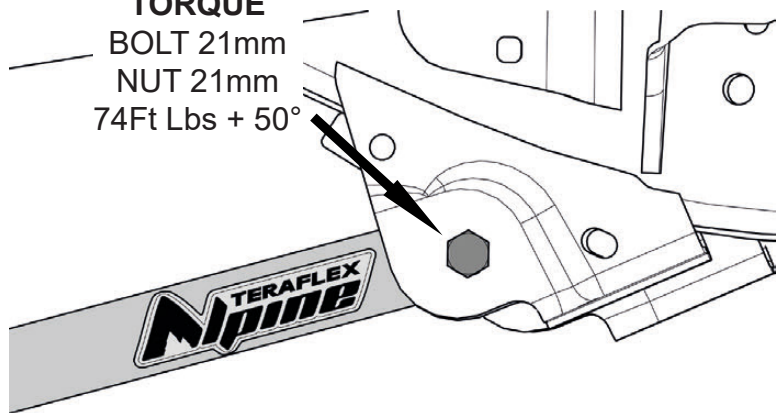

LOOSEN THE CLAMP AND EXTEND THE CONTROL ARM TO THE RECOMMENDED LENGTH. INSTALL THE CONTROL ARM INTO THE AXLE MOUNT.

REFER TO PAGE 11 FOR RECOMENDED CONTROL ARM LENGTHS.

DO NOT TORQUE THE CONTROL ARMS TIGHT UNTIL THE END OF THE INSTALLATION.

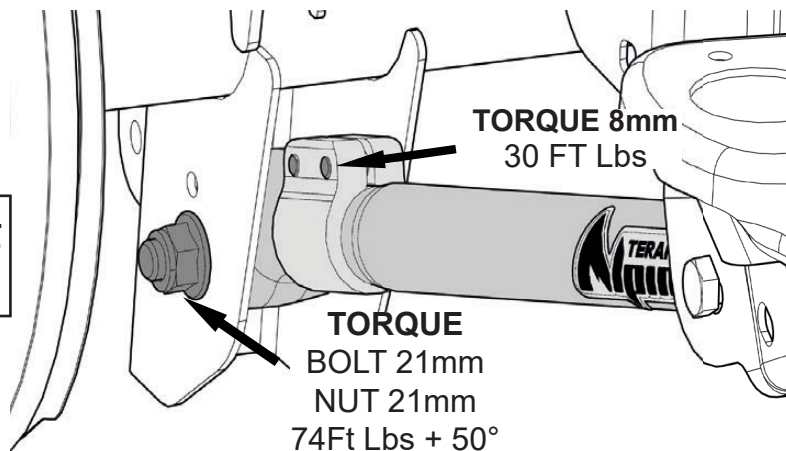

14

REAR UPPER CONTROL ARMS

REMOVE THE FRAME SIDE UPPER CONTROL ARM BOLT

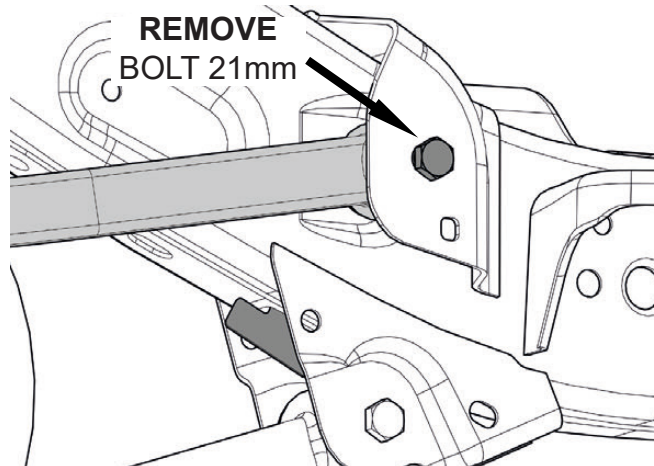

15

REMOVE THE AXLE SIDE UPPER CONTROL ARM BOLT

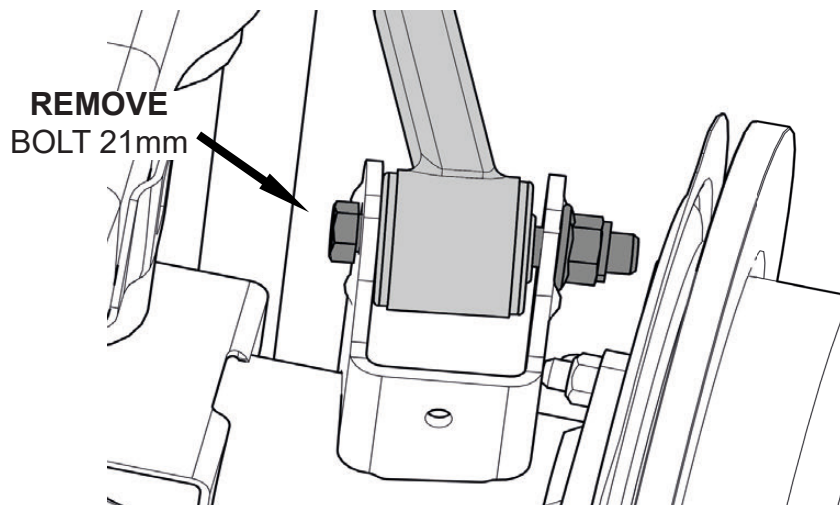

16

INSTALL THE FIXED END OF THE ALPINE CONTROL ARM TO THE FRAME WITH THE STICKER FACING OUT. LEAVE FINGER TIGHT.

DO NOT TORQUE THE CONTROL ARMS TIGHT UNTIL THE END OF THE INSTALLATION.

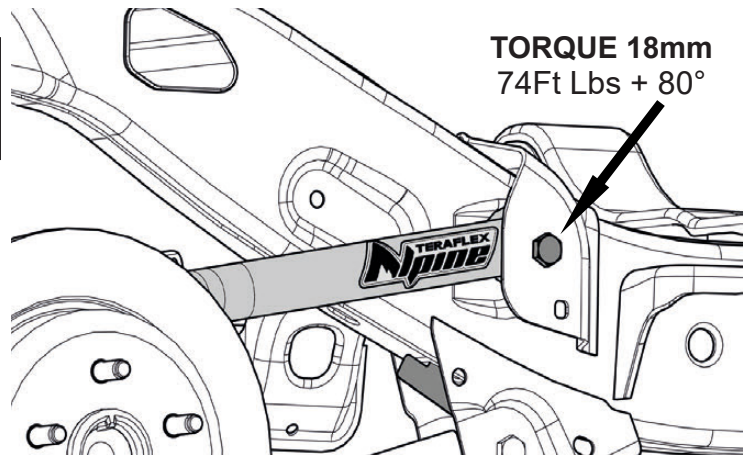

17

LOOSEN THE CLAMP AND EXTEND THE CONTROL ARM TO THE RECOMMENDED LENGTH. INSTALL THE CONTROL ARM INTO THE AXLE MOUNT.

TORQUE
BOLT 21mm
NUT 21mm
74Ft Lbs + 65°

REFER TO PAGE 11 FOR RECOMMENDED CONTROL ARM LENGTHS.

DO NOT TORQUE THE CONTROL ARMS TIGHT UNTIL THE END OF THE INSTALLATION.

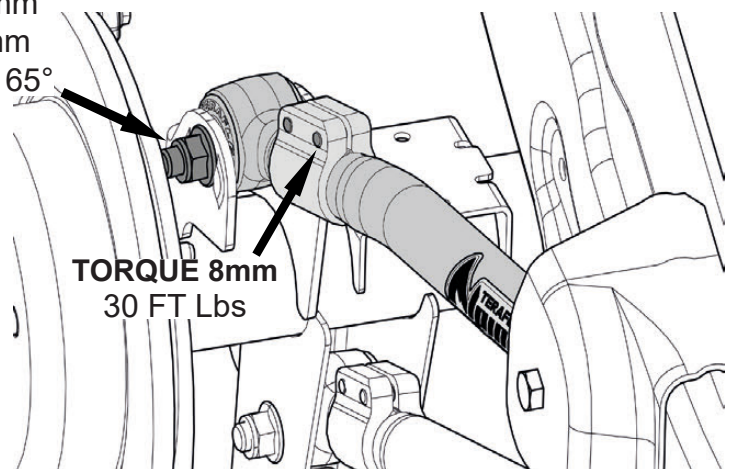

18

NOTE:

*** IF YOU ARE INSTALLING CONTROL ARMS WITH ALPINE BUSHINGS AND THE JEEP WAS RAISED FOR INSTALLATION, LOWER THE JEEP TO THE GROUND AND FINISH THE INSTALLATION BY TORQUING THE CONTROL ARMS.**

*** IF YOU ARE INSTALLING CONTROL ARMS WITH THE ALPINE IR BUSHINGS THE CONTROL ARMS CAN BE TORQUED WITH THE JEEP RAISED IN THE AIR.**

RECOMMENDED CONTROL ARM STARTING LENGTHS

NOTE: THESE ARE ONLY RECOMMENDED STARTING LENGTHS!! EACH JEEP IS DIFFERENT AND MAY NEED TO HAVE THE CONTROL ARM LENGTHS CHANGED FOR PROPER FUNCTION AND SAFE DRIVING.

		Lift Height					
		2.5" Lift		3.5" Lift		4.5" Lift	
		All 8 Arms	Single Pair	All 8 Arms	Single Pair	All 8 Arms	Single Pair
Control Arms	Front Lower	24 1/8"	24 1/4"	24 5/16"	24 7/16"	24 1/2"	24 5/8"
	Front Upper	20"	20 1/8"	20 3/16"	20 1/8"	20 3/8"	20 1/8"
	Rear Lower	20 1/4"	19 5/8"	20 7/16"	19 13/16"	20 5/8"	20"
	Rear Upper	17 5/8"	17 3/8"	17 13/16"	17 3/8"	18"	17 3/8"

NOTE:

- * IF USING FRONT DROP BRACKETS (PN# 1938125), USE THE FACTORY ARM MEASUREMENT AS A STARTING LENGTH FOR THE FRONT LOWER ARMS.
- * IF INSTALLING A SINGLE PAIR OF ARMS TO CORRECT CASTER AND PINION ANGLE, WE RECOMMEND REPLACING THE LOWER ARMS.



JL Adjustable Front Track Bar

1753420

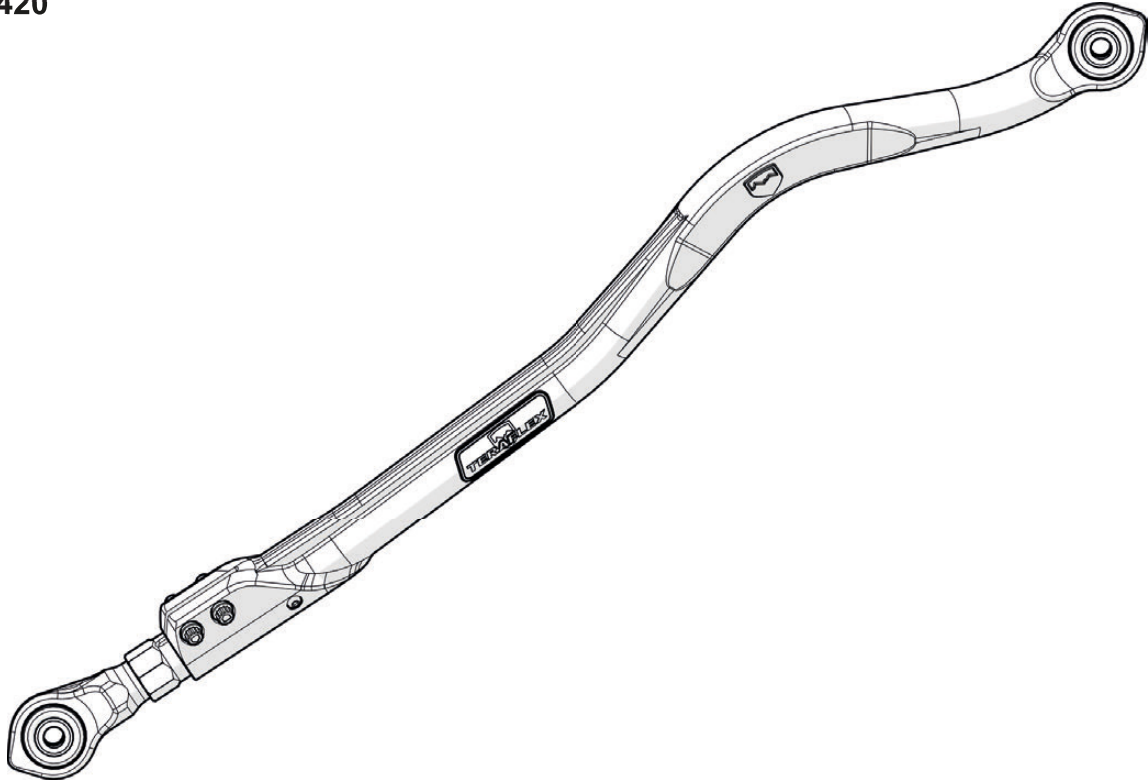

Important Notes:

Prior to beginning this install, or any installation, read the instructions thoroughly to familiarize yourself with the required steps. Evaluate if you are experienced and capable to personally perform these modifications. A factory service manual should be used in conjunction with these installation instructions.

This product will change the highway handling characteristics of your vehicle, exercise caution. After altering the suspension it is always advisable to have an alignment done by a competent 4 wheel drive shop or by an alignment shop that is experienced with lifted 4 wheel drive vehicles.

Refer to the parts list to ensure that all necessary components and hardware has been included. If any parts are missing please contact your local TeraFlex dealer for assistance.

When reinstalling OEM hardware, refer to the torque specs given in the Factory Service Manual.

Tools Needed:

- Metric Sockets and Open End Wrenches
- Torque Wrench
- Factory Service Manual
- General Mechanics Tools

Maintenance Note:

After the first 300 miles and every 3,000 miles after that, re-torque all the suspension components and bolts.

REMOVE THE STOCK TRACK BAR STARTING WITH THE FRAME SIDE THEN THE AXLE SIDE

NOTE: INSTALLATION OF THE FRONT JL TRACK BAR IS BEST COMPLETED WITH THE JEEP LEFT ON LEVEL GROUND

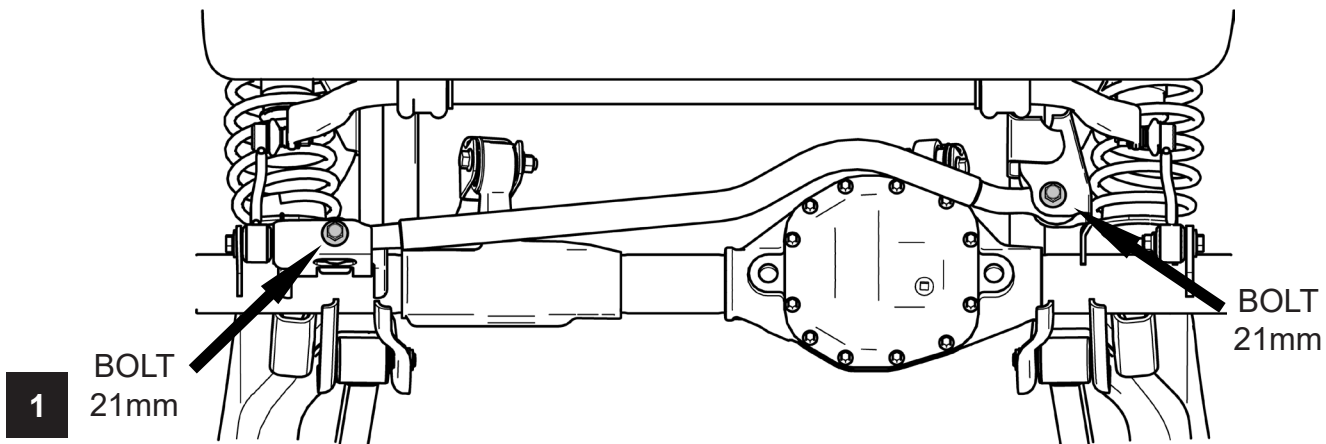

ADJUST THE NEW TRACK BAR TO THE APPROXIMATE LENGTH NEEDED TO CENTER THE AXLE UNDER THE JEEP

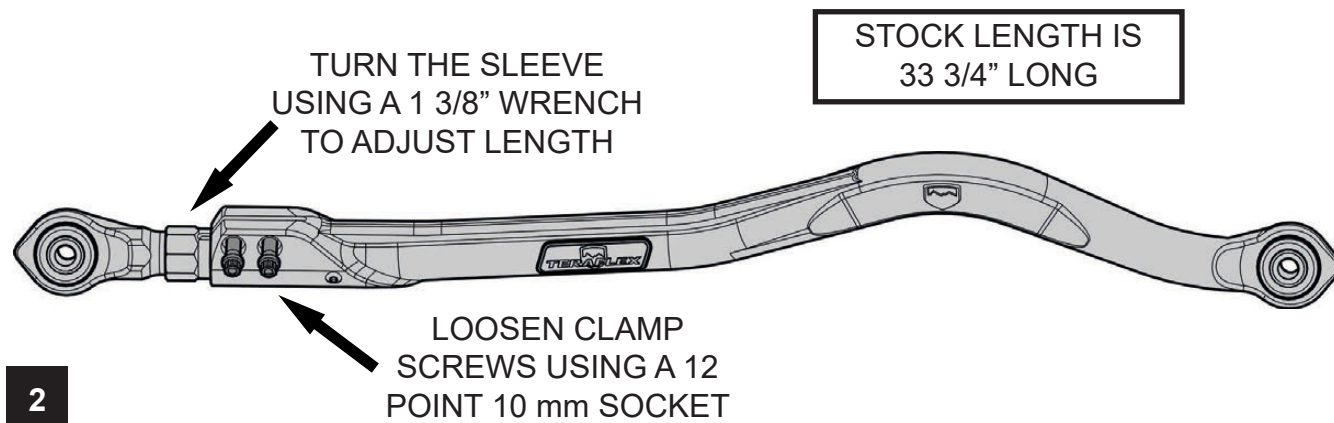

LOOSELY INSTALL THE TRACK BAR ONTO THE AXLE WITH THE STOCK HARDWARE

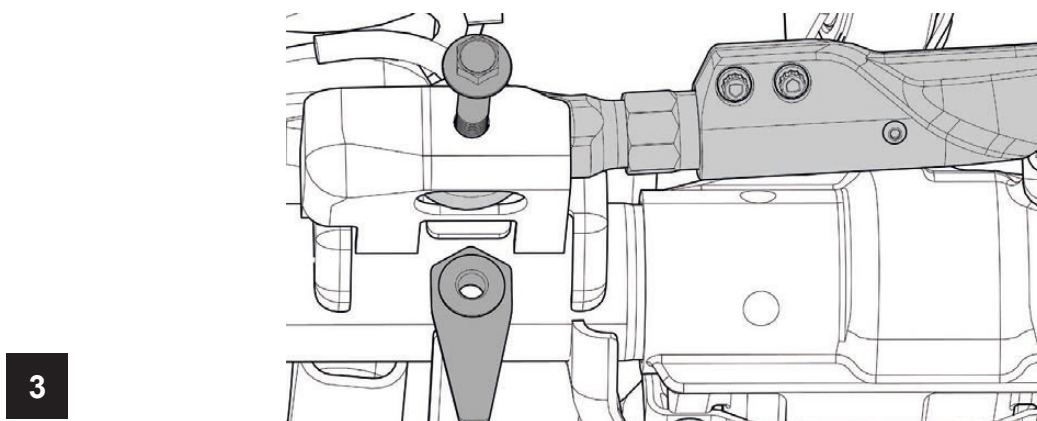

**INSTALL THE TRACK BAR ONTO THE FRAME USING THE STOCK HARDWARE.
HAVE SOMEONE TURN THE STEERING WHEEL TO ALIGN THE HOLE OR USE A
RATCHET STRAP**

**TORQUE 21mm
52Ft Lbs + 115°**

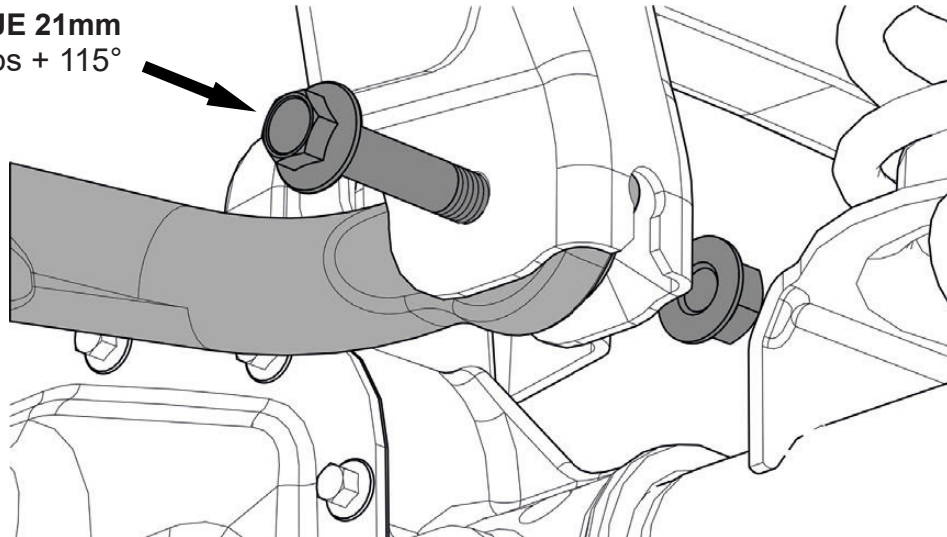

4

**VERIFY THAT THE AXLE IS CENTERED UNDER THE JEEP AND ADJUST AS NEEDED.
ONCE THE AXLE IS CENTERED UNDER THE JEEP TIGHTEN THE CLAMP SCREWS AND
ADJUST THE DRAG LINK TO STRAIGHTEN THE STEERING WHEEL IF NEEDED.**

**NOTE: DEPENDING ON WHAT TOOLS YOU HAVE TO WORK WITH YOU MAY NEED TO
REMOVE THE TRACK BAR FROM THE AXLE TO TORQUE THE CLAMP SCREWS**

**TORQUE 21mm
52Ft Lbs + 155°**

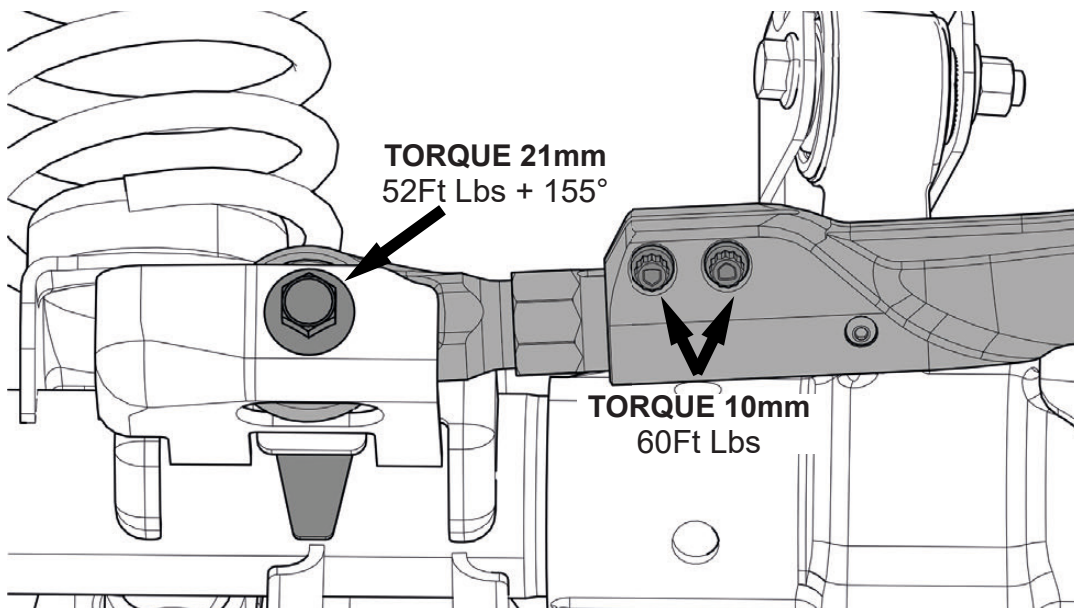

5

TERAFLEX

PRODUCT INFORMATION

MAINTENANCE INFORMATION:

It is the buyer's responsibility to have all suspension, drivetrain, steering, and other components checked for proper tightness and torque after the first 100 miles and every 3000 miles after that.

NOTICE TO INSTALLER:

The enclosed "Warning to Driver" sticker must be installed in the vehicle in driver's view. This sticker is to act as a constant safety reminder when operating the vehicle. It is your responsibility as the equipment installer to install the provided sticker and to forward the product instructions to the vehicle's owner for review. If a "Warning to Driver" sticker or product installation guide were not included in the kit, FREE replacement stickers and instructions are available by request. It is the installer's duty to ensure a safe and controllable vehicle after the modifications have been performed.

WARNING:

Neither the seller nor the manufacturer will be liable for any loss, damage, or injury directly or indirectly arising from the use of or inability to determine the use of these products. Before using, the user shall determine the suitability of the products for its intended use, and the user shall assume all responsibility and risk in connection therewith.

WARNING TO DRIVER:

This vehicle has been modified to enhance off road performance and has unique handling characteristics. Use in harsh environments can cause extreme stress on the components. Vehicle should be inspected after being off road to make sure that all the components are in working order and safe to travel on the highway. All fasteners should be checked so that they are at the correct torque specifications as the vibration and stresses from off roading may cause critical fasteners to work loose. Extra care should be taken to inspect the critical components, steering, and brake systems. During each oil change components such as arms, tie rod ends, etc should be greased and checked for excessive wear. Any worn components should be replaced. When returning to the pavement always set or restore tire air pressure to the factory recommendation and connect or engage any disabled sway bar mechanisms. Because of the higher center of gravity and larger tires, this vehicle handles and reacts differently than many passenger cars, both on and off road. You must drive it safely! Extreme care should be taken to prevent vehicle rollover or loss of control, which can result in serious injury or death. Avoid sudden sharp turns or abrupt maneuvers. Generally, braking performance and capabilities are decreased when significantly larger/heavier tires are used, especially when used in combination with transfer case low-range reduction kits. Take this into consideration while driving. Do not add, alter or fabricate any factory or aftermarket parts to increase vehicle height over the intended height of the TeraFlex product purchased. Mixing component brand is not recommended. TeraFlex Inc. will not be responsible for any altered product or any improper installation or use of our products. We will be happy to answer any questions concerning the design, function, and correct use of our products. It is ultimately the buyer's responsibility to have all bolts/nuts checked for tightness after the first 100 miles and then every 3000 miles. Wheel alignment, steering system, suspension and drive line systems must be inspected by a qualified professional mechanic at least every 3000 miles.