



# Jeep JL 2.5" Spacer Lift

Kit #1365200 - Jeep JL Wrangler, 4DR 2.5" Spacer Lift Kit (Sport/Sahara Edition)

Kit #1365300 - Jeep JL Wrangler, 2DR 2.5" Spacer Lift Kit (Sport/Sahara Edition)

Kit #1365210 - Jeep JL Wrangler, 4DR 2.5" Spacer Lift Kit (Rubicon Edition)

Kit #1365310 - Jeep JL Wrangler, 2DR 2.5" Spacer Lift Kit (Rubicon Edition)

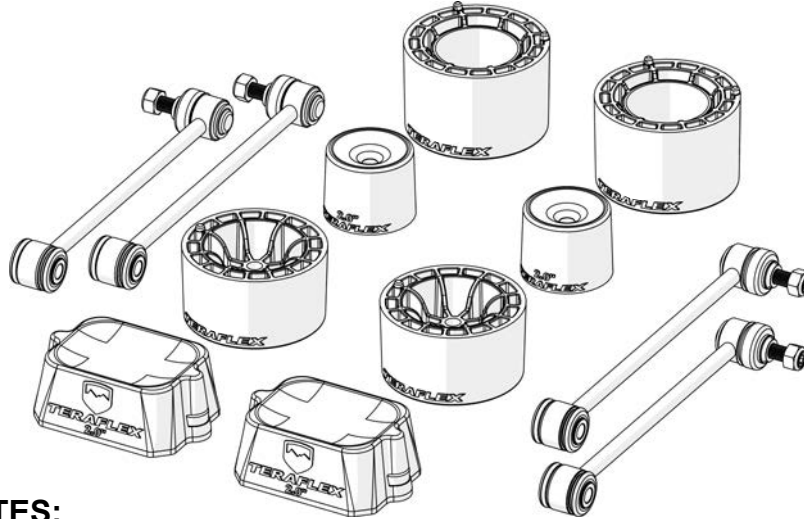

## IMPORTANT NOTES:

Prior to beginning this install, or any installation, *read the instructions thoroughly* to familiarize yourself with the required steps. Evaluate if you are experienced and capable to personally perform these modifications. A factory service manual should be used in conjunction with these installation instructions.

This product will change the highway handling characteristics of your vehicle, exercise caution. After altering the suspension it is always advisable to have an alignment done by a competent 4 wheel drive shop or by an alignment shop that is experienced with lifted 4 wheel drive vehicles.

Refer to the parts list to ensure that all necessary components and hardware has been included. If any parts are missing please contact your local TeraFlex dealer for assistance.

This kit is optimized to run 35" tires. If running 37" tires is desired Bumpstop Spacer Kit #1959300 can be purchased. Refer to page 13 of this guide for more information on the number of Bumpstop Spacers needed for your application.











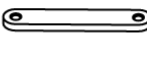

***When tightening OEM control arm and track bar hardware refer to the torque specs given in the Factory Service Manual.***

## TOOLS NEEDED:

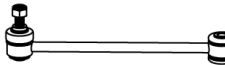
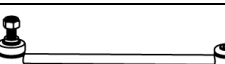
- Factory Service Manual
- Torque Wrench
- Basic Mechanics Tool Set
- Locking Pliers (2 Pairs)

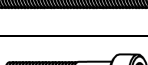
## MAINTENANCE INFORMATION:

It is the buyer's responsibility to have all suspension, drivetrain, steering, and other components checked for proper tightness and torque after the first 300 miles and every 3000 miles after that.

Item #	Image	Description	Part No.	Sport / Sahara		Rubicon	
				2DR	4DR	2DR	4DR
1		Front Spring Spacer	05-01-109-300	-	2	-	2
			05-01-109-200	2	-	2	-
2		Rear Spring Spacer	05-01-209-250	2	2	2	2
3		Front Bumpstops	12-01-109-200	2	2	2	2
4		Rear Bumpstops	12-01-209-200	2	2	2	2
5		Rear Bumpstop Bracket	12-02-209-002	2	2	2	2
6		Rear Bumpstop Mounting Strap	12-02-209-001	2	2	2	2
7		Front Bumpstop Spacers	12-02-109-050	4	4	-	-
8		Rear Bumpstop Spacers	12-02-209-050	2	2	-	-
9		Front Swaybar Link 10.75"	744500	2	2	2	2
10		Rear Swaybar Link 11.50"	21-01-001-115	2	2	2	2
11		M10 x 1.5 Fuji Nut	23-07-03-001	6	6	6	6
12		M10 x 1.5 x 120mm Hex Cap Screw	45-01-003-005	2	2	2	2
13		M10 x 1.5 x 100mm Flat Socket Cap Screw	45-04-003-001	2	2	2	2
14		M10 x 1.5 x 50mm Socket Cap Screw	45-03-003-001	4	4	4	4
15		M10 x 1.5 x 25mm Button Socket Cap Screw	45-05-003-003	4	4	4	4
16		M10 Flat Washer	45-10-003-001	2	2	2	2
17		M10 Lock Washer	45-12-002-001	4	4	4	4
18		M10 Slotted Washer	47-02-001-001	2	2	2	2
19		Nut Wrench Tool	600271	1	1	1	1
20		M12 x 1.75 x 55mm Button Socket Cap Screw	45-05-003-001	2	2	2	2
21		M12 x 1.75mm Black Fuji Nut	23-07-02-002	2	2	2	2

### LIFT AND SUPPORT AT FRAME

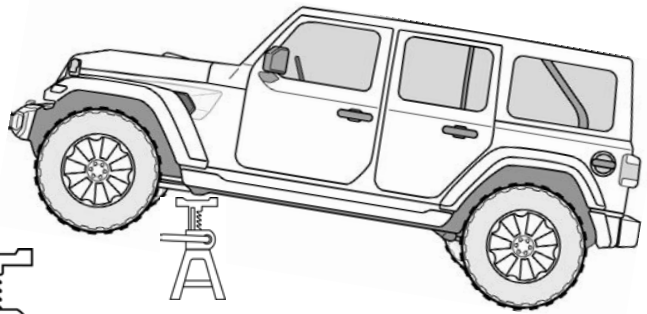
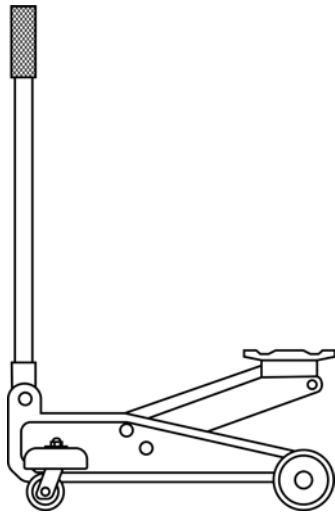

### REMOVE TIRES AND WHEELS

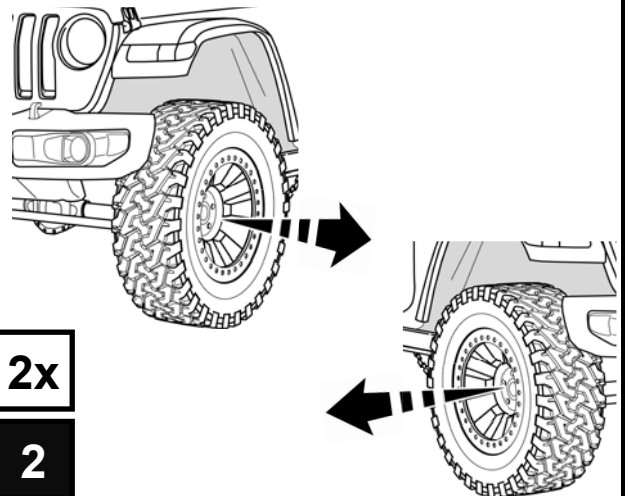
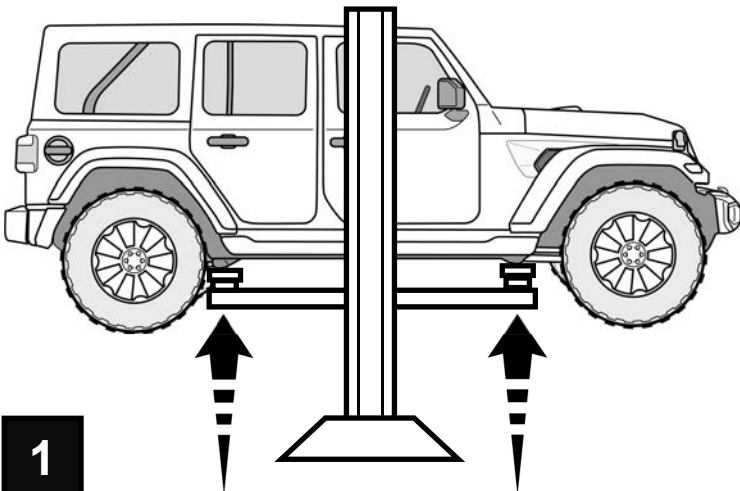

2x

2

### SUPPORT FRONT AXLE

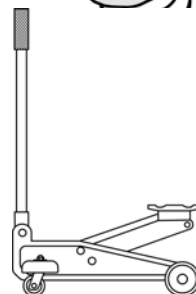
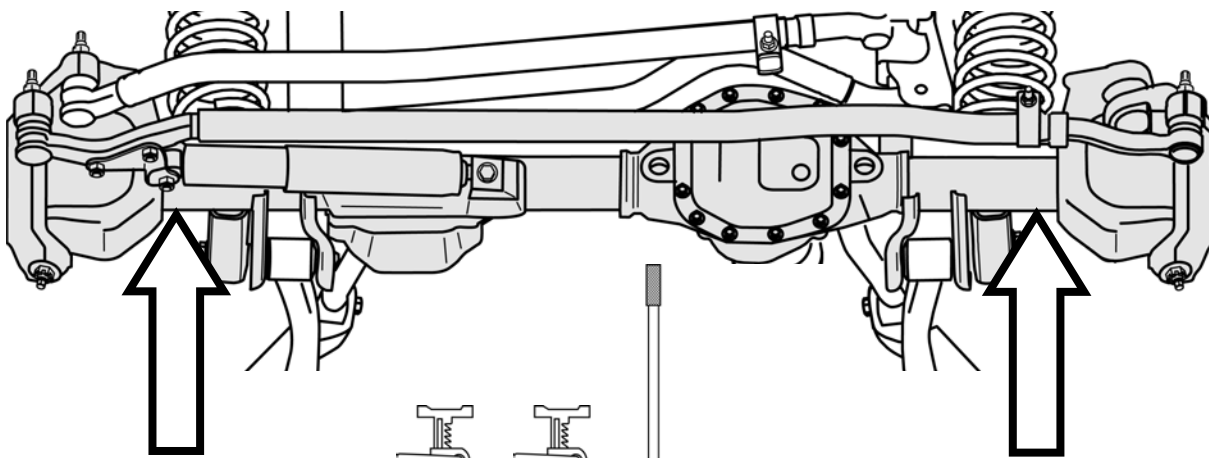

3

**REMOVE SWAY BAR LINK & REMOVE TRACK BAR AT AXLE**

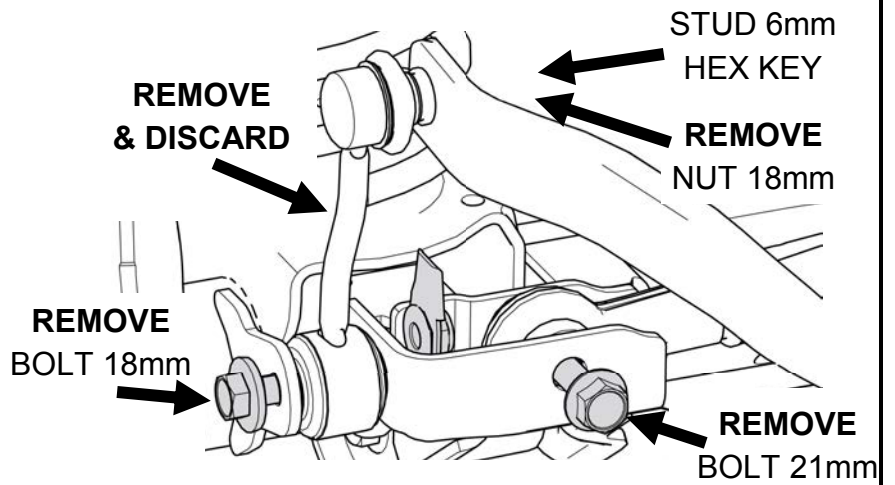
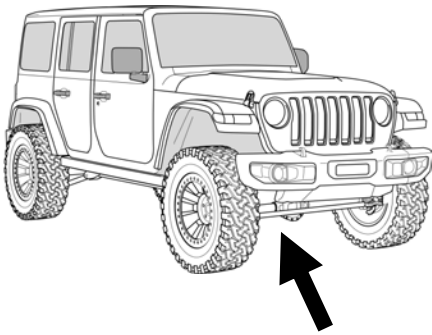

**4**

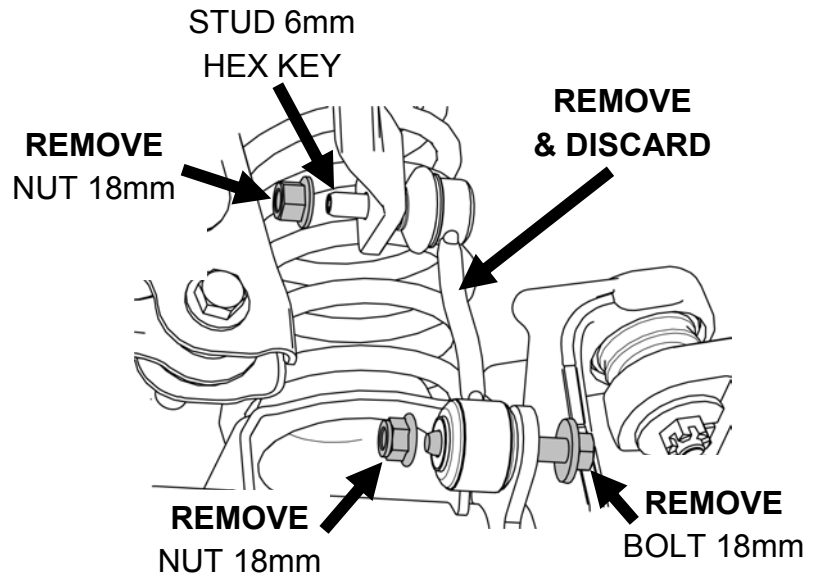
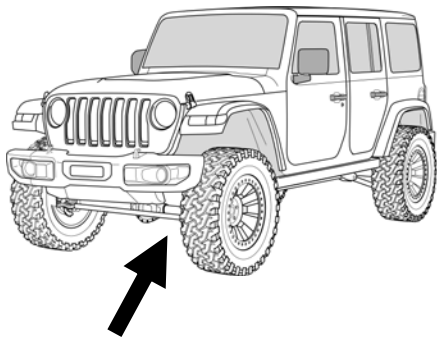

**5**

**REMOVE AND DISCARD BRAKE LINE BRACKETS FROM LOWER CONTROL ARMS**

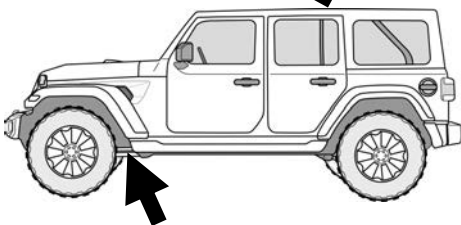
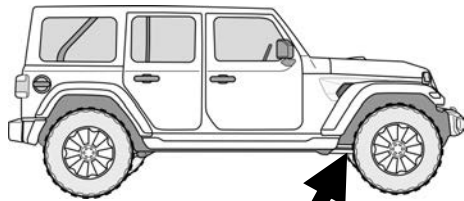

**2x**

**6**

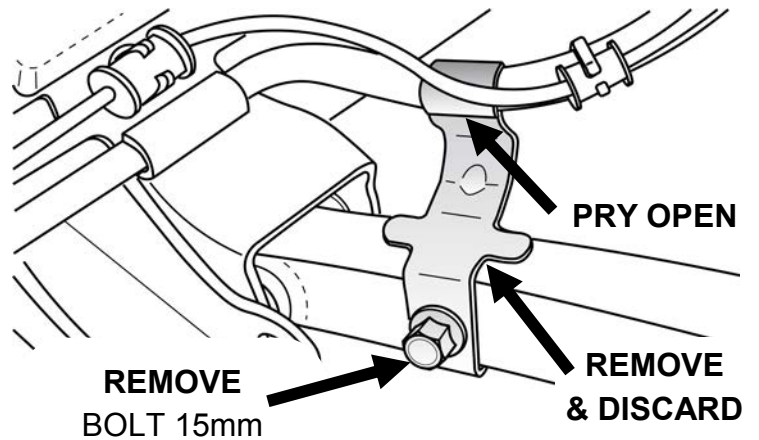

**DISCONNECT ACTUATORS AND VENT HOSE AT THE FRONT AXLE**

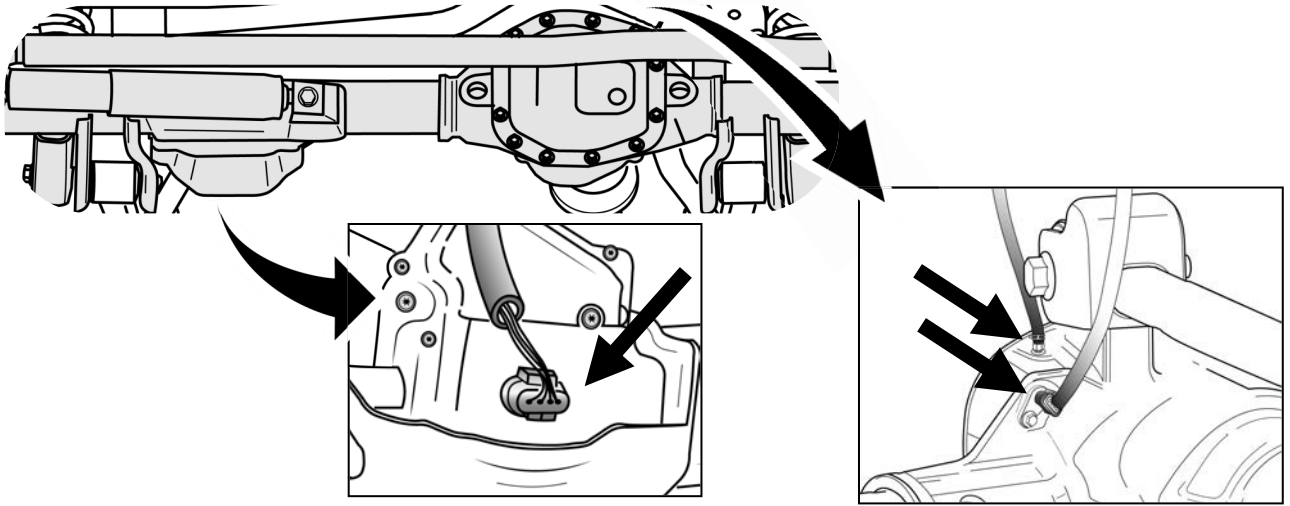

**7**

**LOOSEN FRONT CONTROL ARM BOLTS**

**NOTE: DO NOT REMOVE THE CONTROL ARM BOLTS**

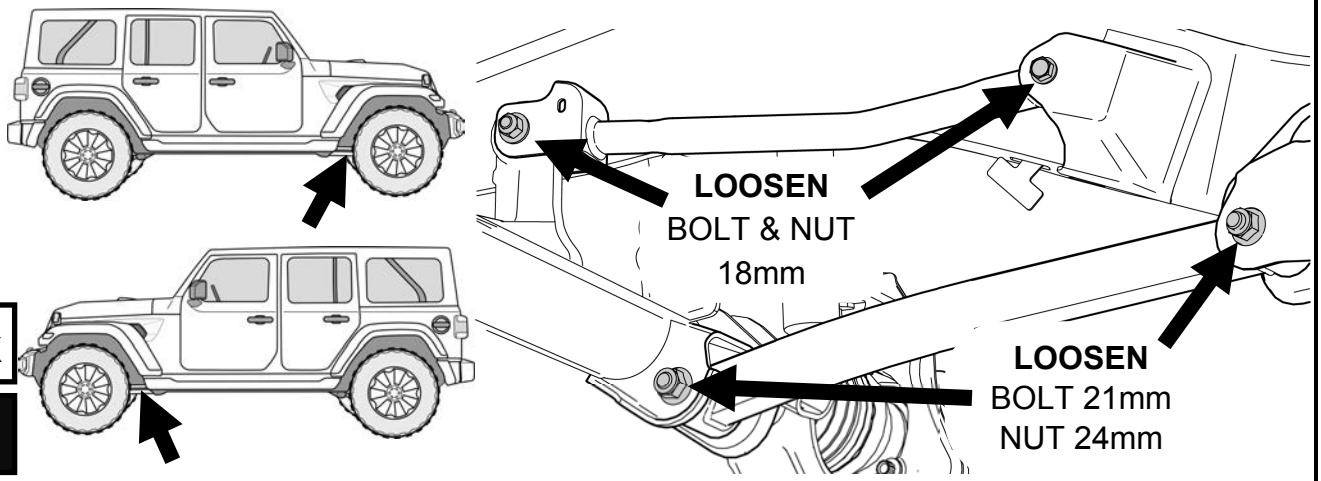

**LOOSEN  
BOLT & NUT  
18mm**

**LOOSEN  
BOLT 21mm  
NUT 24mm**

**2x**

**8**

**REMOVE SHOCKS**

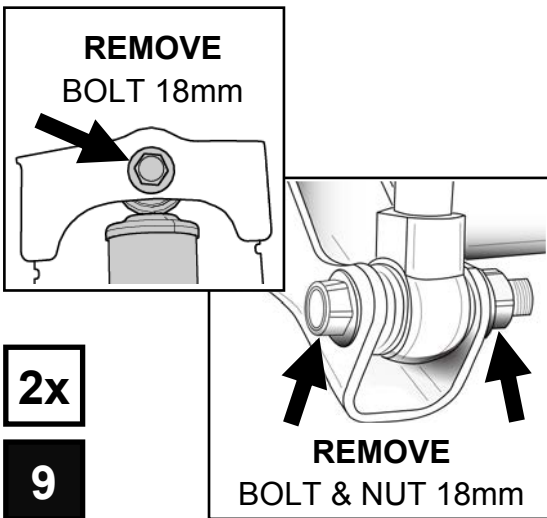

**REMOVE  
BOLT 18mm**

**REMOVE  
BOLT & NUT 18mm**

**2x**

**9**

**LOWER AXLE & REMOVE SPRINGS**

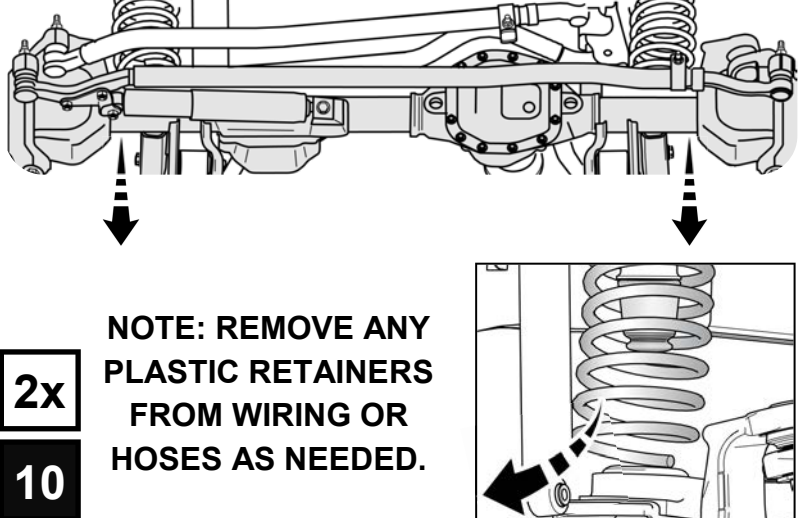

**NOTE: REMOVE ANY  
PLASTIC RETAINERS  
FROM WIRING OR  
HOSES AS NEEDED.**

**2x**

**10**

**INSTALL SPRING SPACER AND FACTORY SPRING ISOLATOR ONTO JOUNCE TUBES**

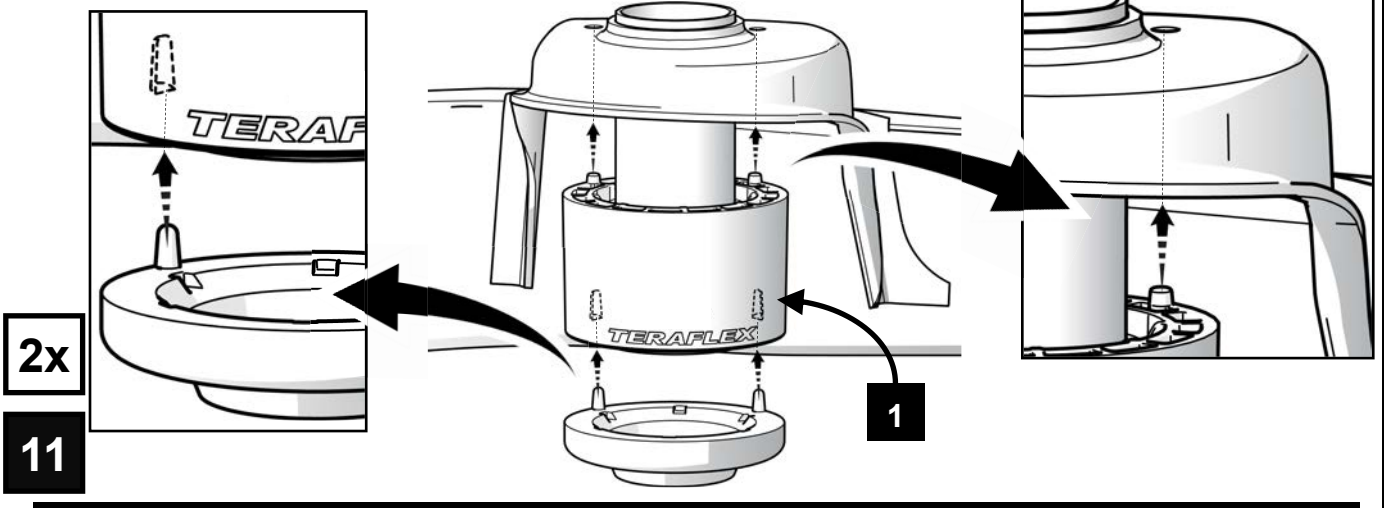

**REINSTALL THE SPRINGS WITH LOWER BUMPSTOP SPACER INSIDE**



**TIP: ZIP TIE BUMPSTOP SPACER TO SPRING**

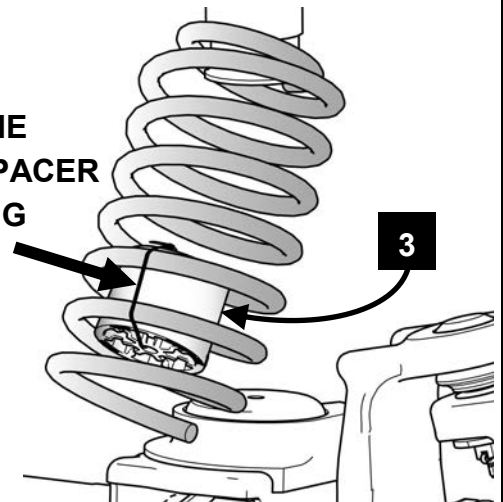

**INSTALL BUMPSTOP TOP SPACER ONTO SPRING MOUNT**

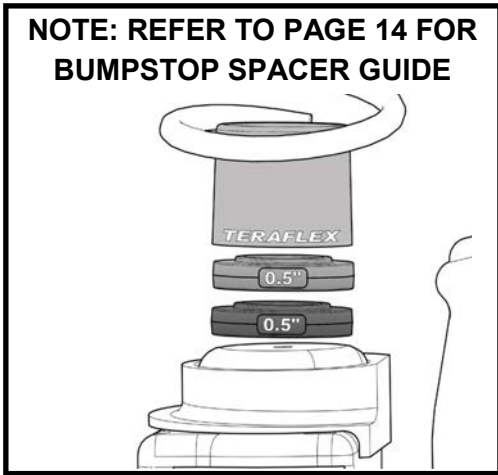

**TORQUE 12 FT - LBS.  
6MM HEX KEY**

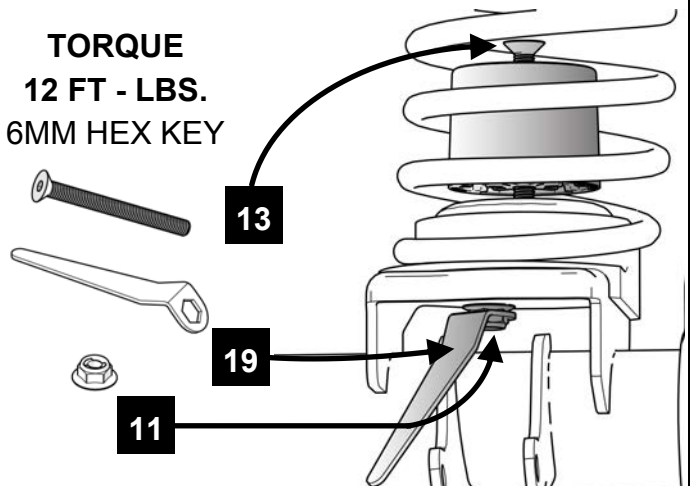

**SEAT SPRINGS INTO LOWER SPRING ISOLATOR**

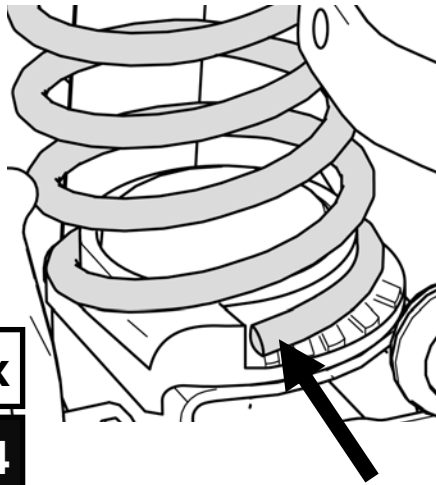

**2x**

**14**

**RAISE AXLE & INSTALL REPLACEMENT SHOCKS**

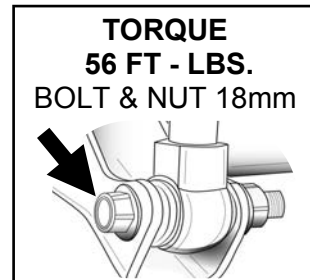
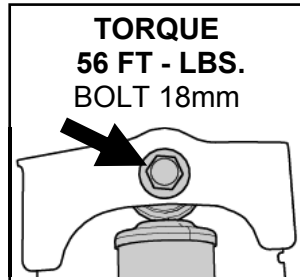
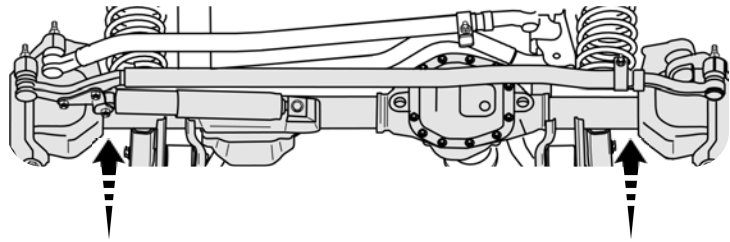

**INSTALL NEW SWAY BAR LINKS**

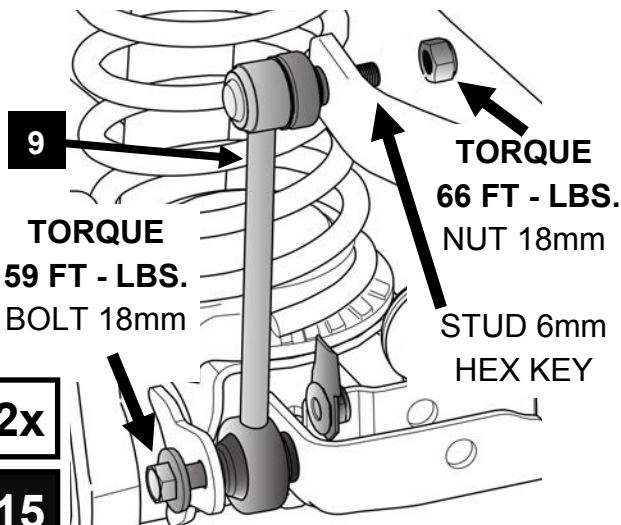

**2x**

**15**

**RECONNECT ACTUATORS AND VENT HOSE TO FRONT AXLE**

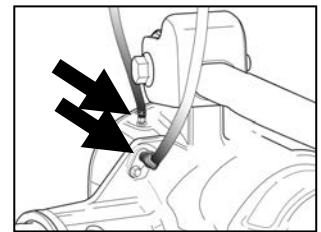
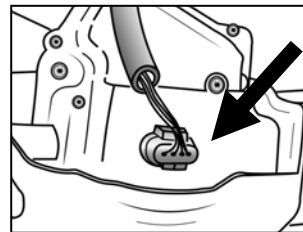

**RECONNECT PLASTIC RETAINERS FROM WIRING OR HOSES AS NEEDED**

**NOTE: DO NOT TIGHTEN THE CONTROL ARM BOLTS UNTIL THE JEEP IS ON THE GROUND**

**16**

**NOTE: IF ONLY FRONT OF JEEP WAS LIFTED REINSTALL TIRES & WHEELS AND LOWER JEEP BACK TO THE GROUND BEFORE LIFTING THE REAR**

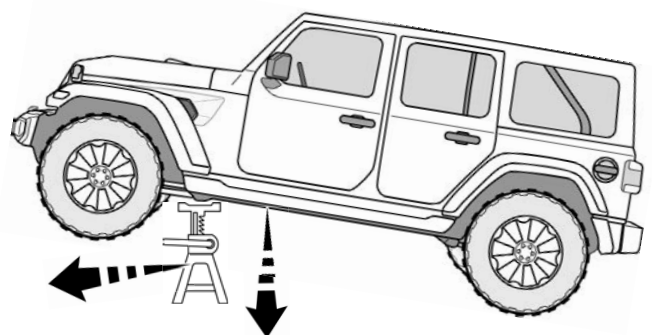
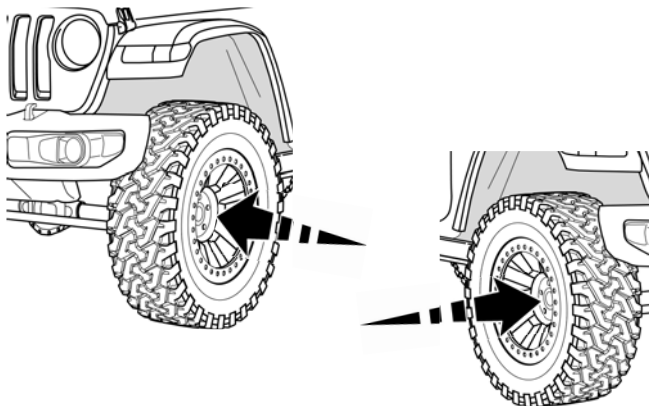

**LIFT AND SUPPORT AT FRAME**

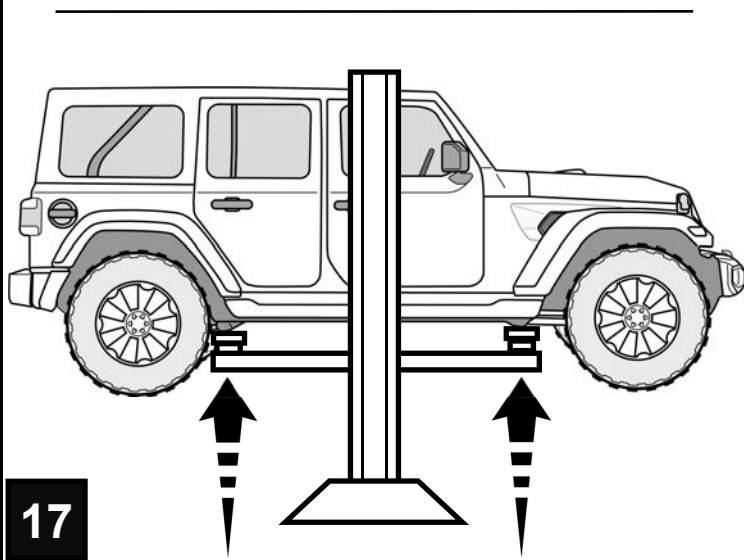
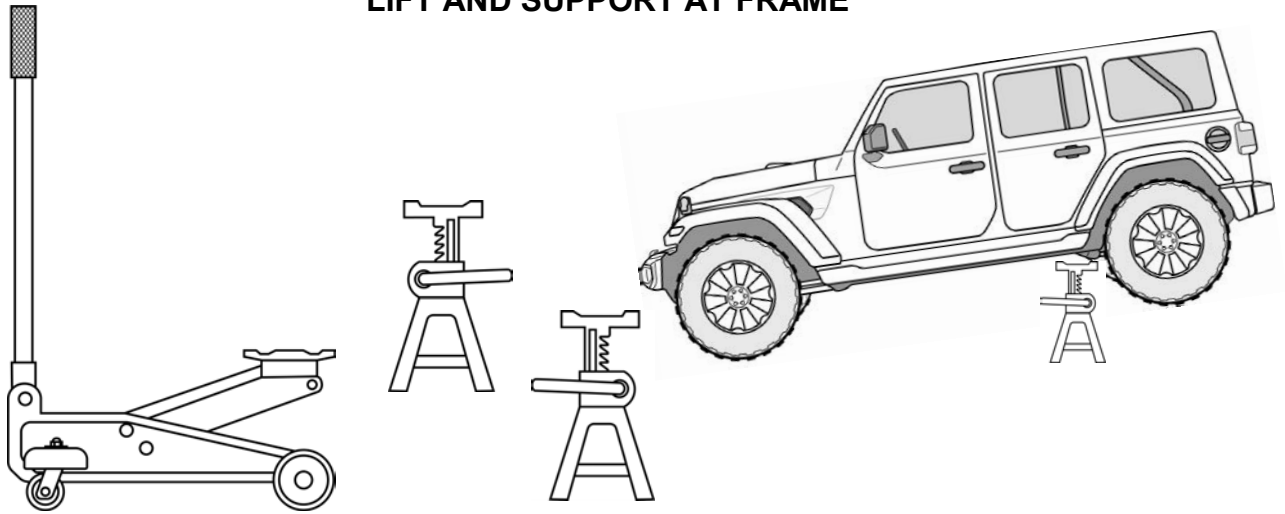

**17**

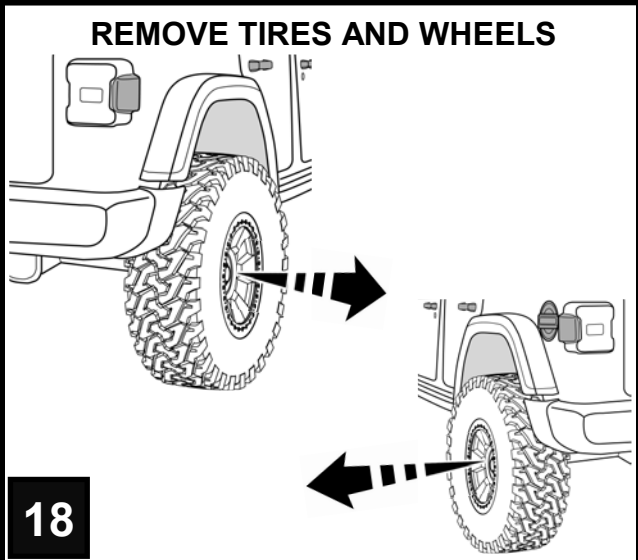

**18**

**SUPPORT REAR AXLE**

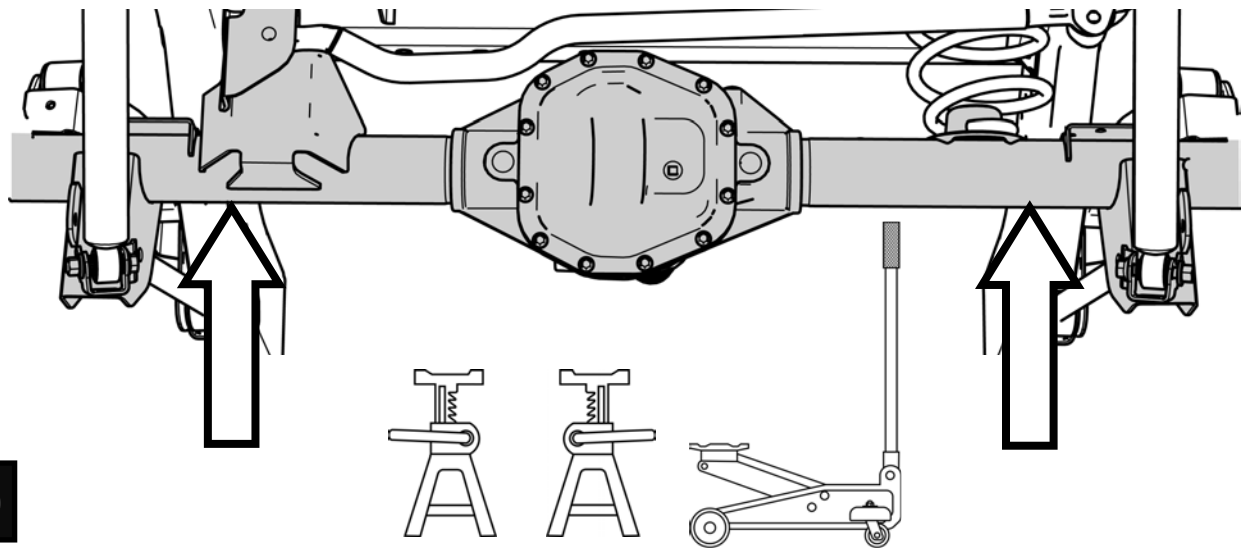

**19**



**REMOVE E-BRAKE CABLE BRACKET AND DISCARD**

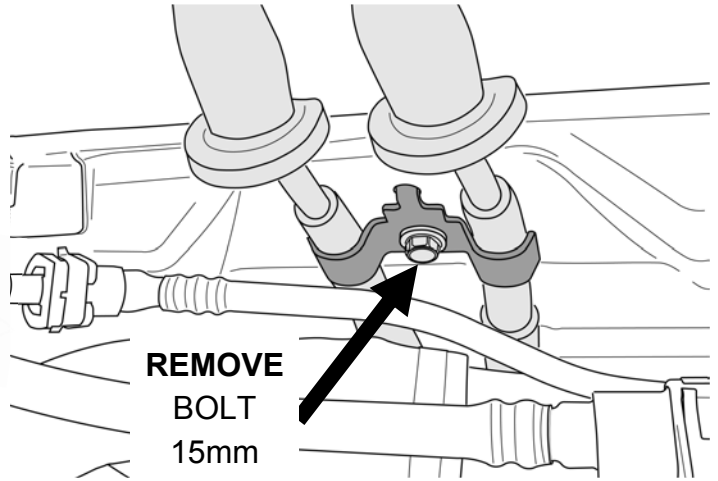
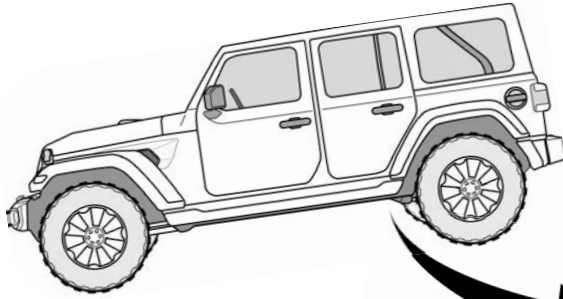

**20**

**SET E-BRAKE AND CLAMP BOTH E-BRAKE EYELETS AGAINST BACKING PLATES WITH LOCKING PLIERS**

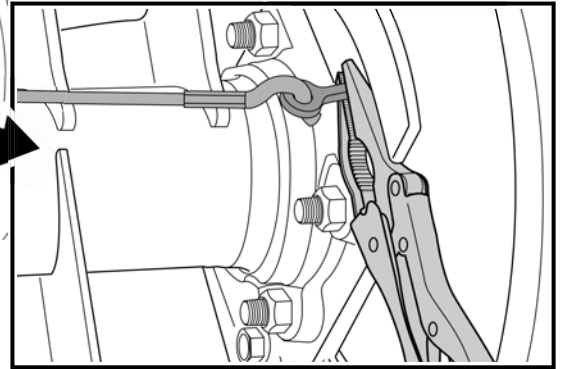
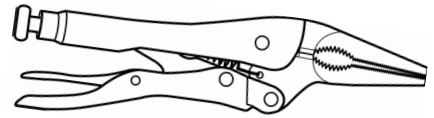
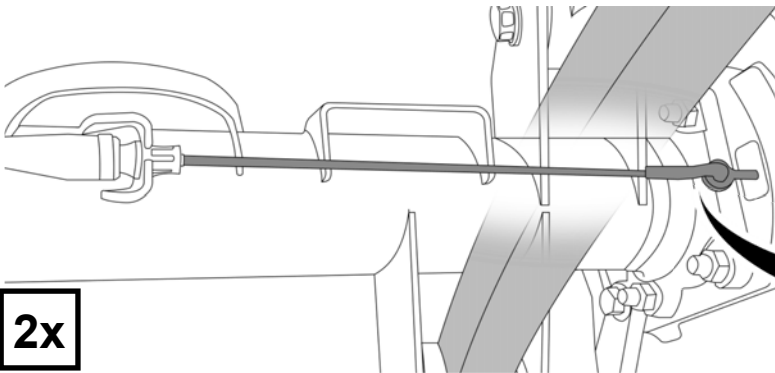

**2x**

**21**

**RELEASE E-BRAKE AND DISCONNECT CABLES FROM BOTH EYELETS AND AXLE BRACKETS**

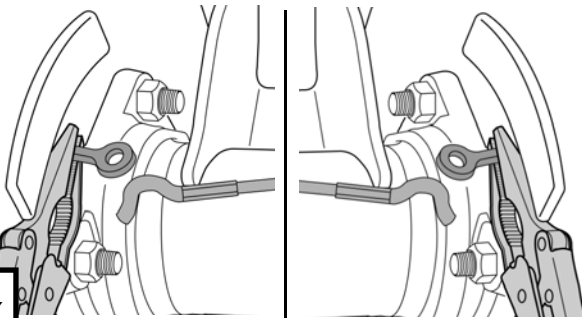

**2x**

**22**

**NOTE: DO NOT REMOVE LOCKING PLIERS FROM E-BRAKE EYELET**

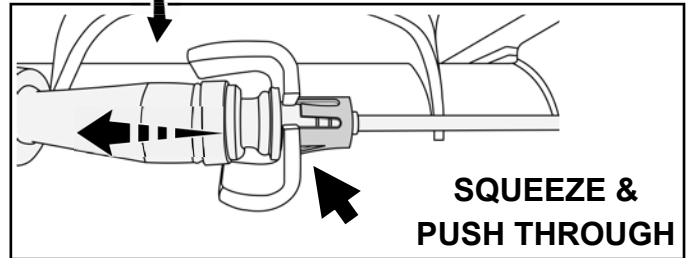
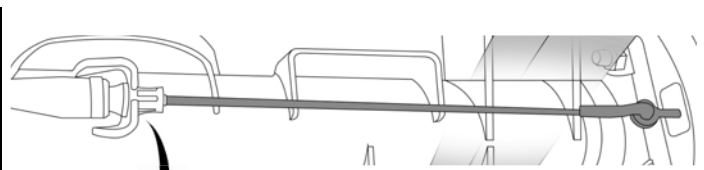

**SQUEEZE & PUSH THROUGH**

**REROUTE E-BRAKE CABLES UNDER CROSS MEMBER AND FUEL LINES.**

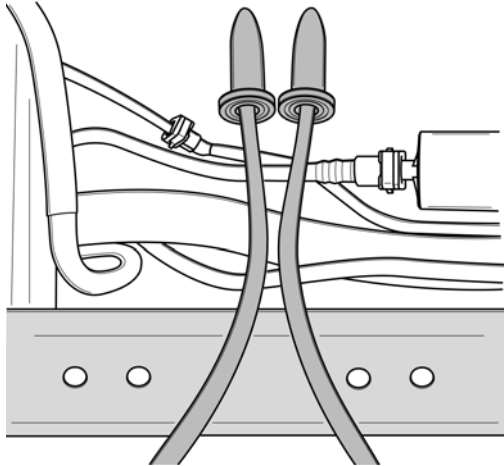

**23**

**RECONNECT E-BRAKE CABLES TO THE AXLE BRACKETS AND THEN THE E-BRAKE EYELETS.**

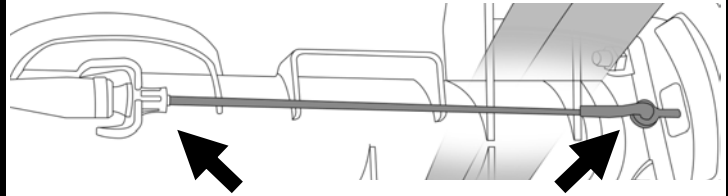

**2x**

**24**

**REMOVE CLAMPS FROM E-BRAKE EYELET**

**LOOSEN REAR CONTROL ARM BOLTS  
DO NOT REMOVE THE CONTROL ARM BOLTS**

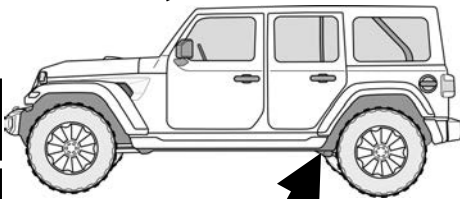
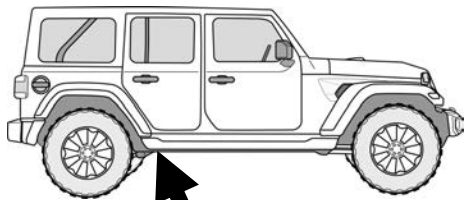

**2x**

**25**

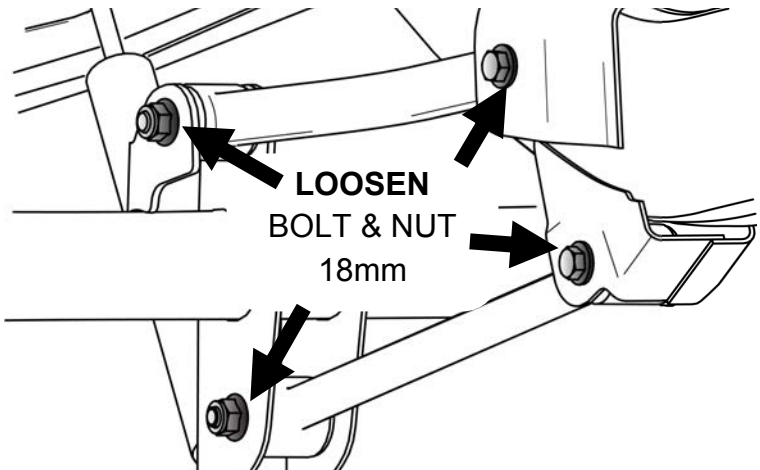

**REMOVE SWAY BAR LINKS**

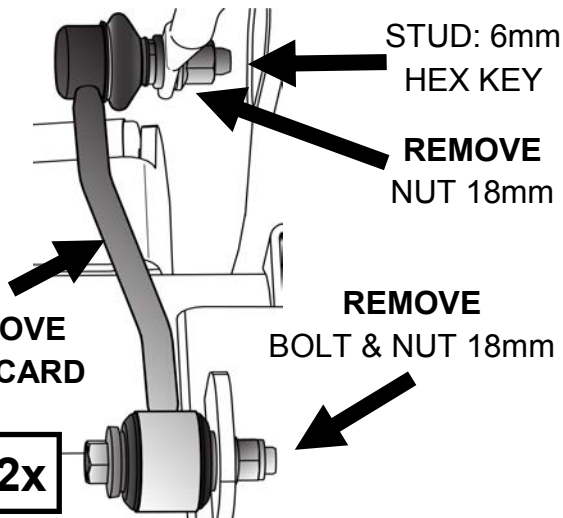

**26**

**2x**

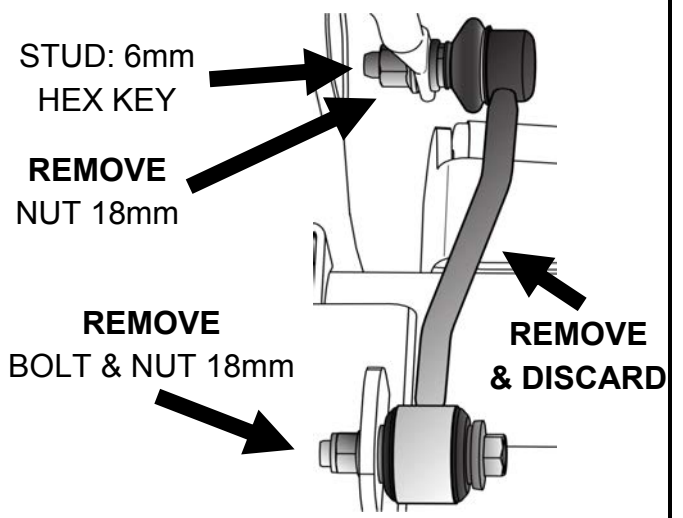

**REMOVE BRAKE LINE BRACKETS FROM AXLE**

**REMOVE  
BOLT 13mm**

**REMOVE  
BOLT 13mm**

**2x**

**27**

**REMOVE THE TRACK BAR FROM THE AXLE**

**REMOVE  
BOLT 21mm**

**28**

**REMOVE THE REAR SHOCKS**

**2x**

**29**

**REMOVE  
BOLT 18mm**

**REMOVE  
BOLT & NUT 18mm**

**LOWER AXLE AND REMOVE THE SPRINGS**

**2x**

**30**

**NOTE: REMOVE ANY PLASTIC  
RETAINERS FROM WIRING OR  
HOSES AS NEEDED.**

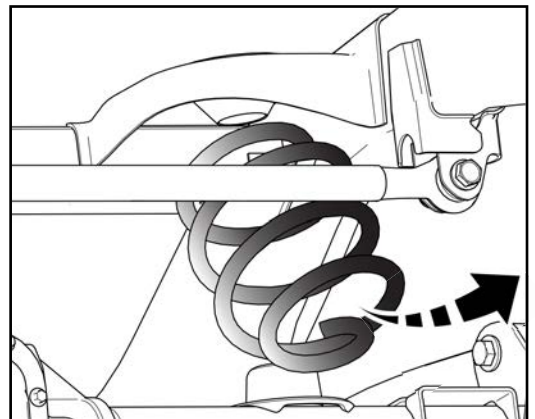

**INSTALL REAR SPRING SPACER AND FACTORY SPRING ISOLATOR**

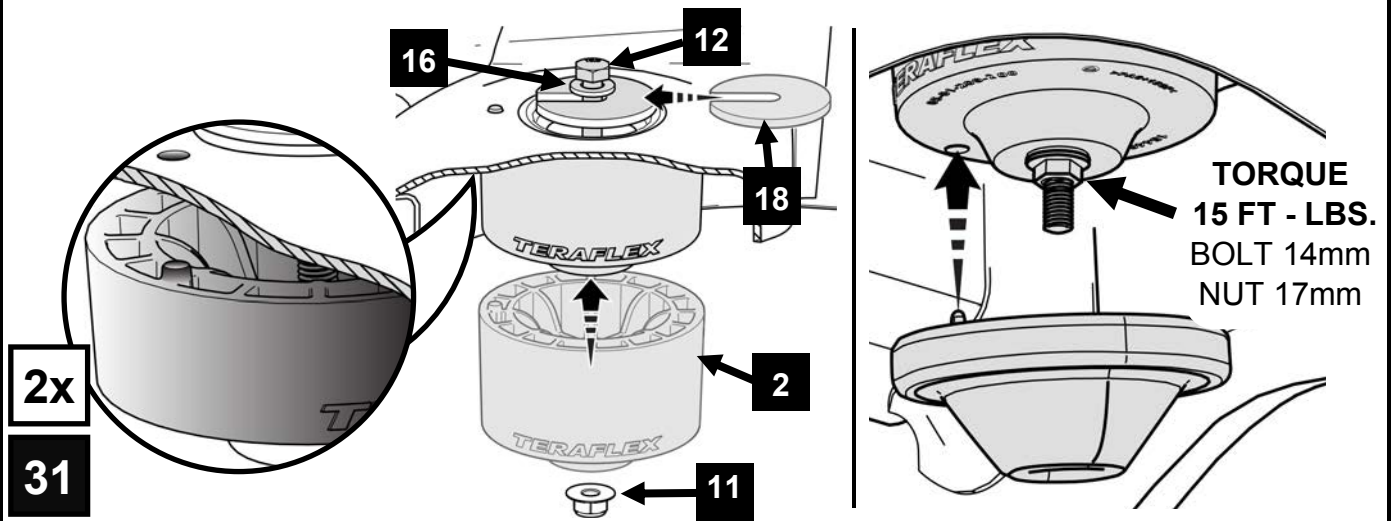

**REINSTALL REAR SPRINGS**

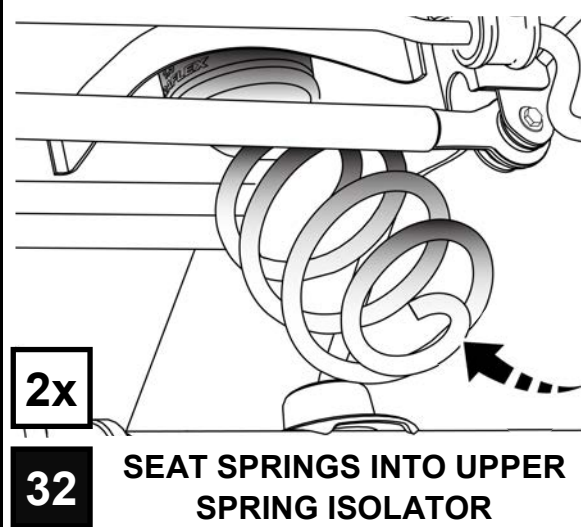

**SEAT SPRINGS INTO UPPER SPRING ISOLATOR**

**RAISE AXLE & INSTALL REPLACEMENT SHOCKS**

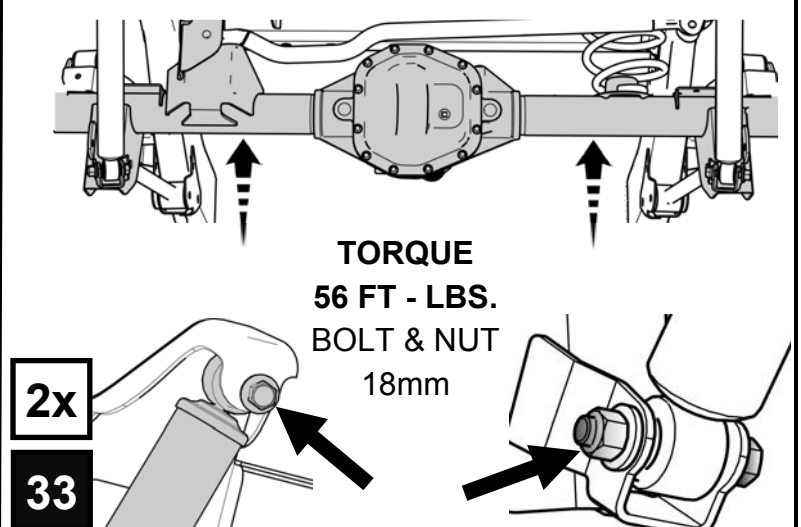

**REINSTALL BRAKE LINE BRACKETS**

RECONNECT PLASTIC RETAINERS FROM WIRING OR HOSES AS NEEDED

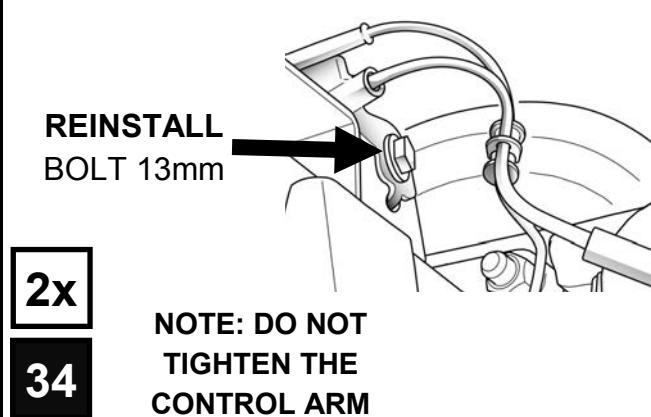

**NOTE: DO NOT TIGHTEN THE CONTROL ARM**

**INSTALL NEW SWAY BAR LINKS**

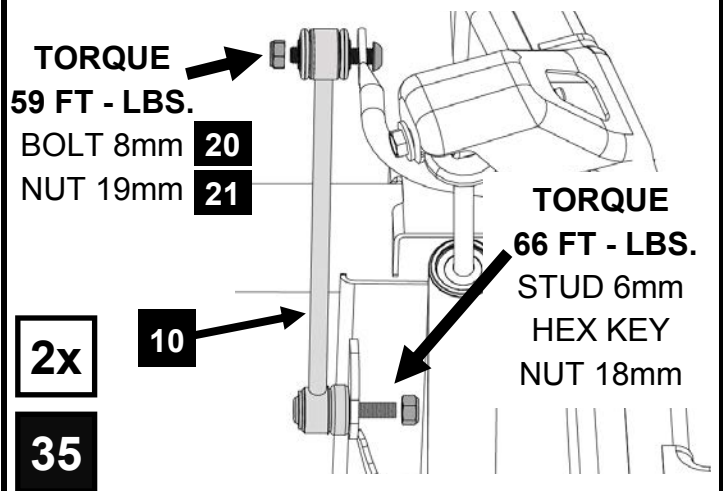

**INSTALL BUMPSTOP TOP SPACER ONTO AXLE**

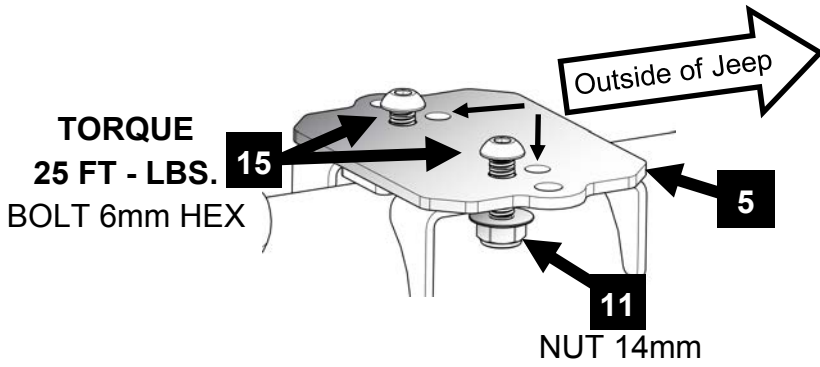

**NOTE: REFER TO PAGE 14 FOR BUMPSTOP SPACER GUIDE**

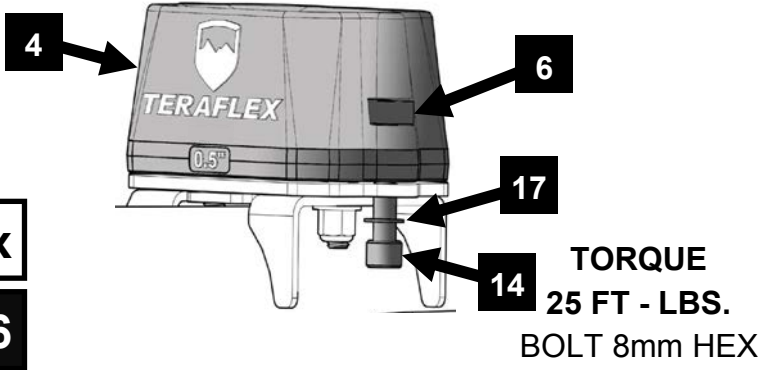
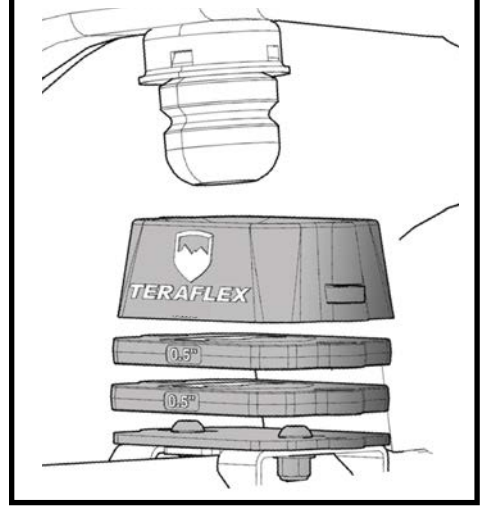

**2x**  
**36**

**REINSTALL TIRES AND WHEELS AND LOWER JEEP TO GROUND**

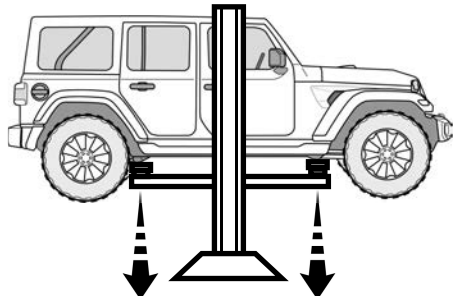

**37** **TORQUE TO FACTORY SPEC**

**REINSTALL TRACK BARS AND TORQUE TO THE FOLLOWING SPECS**

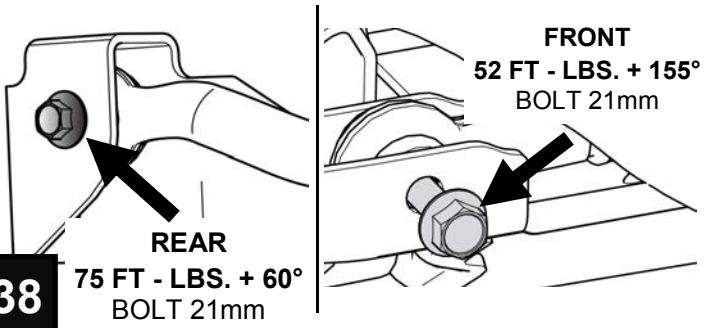

**38**

**TORQUE CONTROL ARMS TO THE FOLLOWING SPECS**

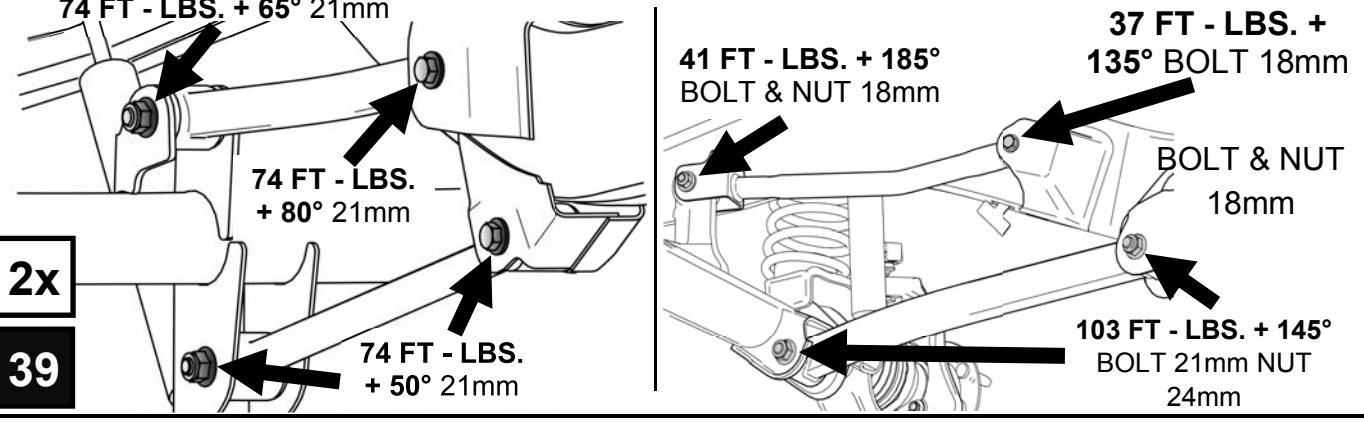

**2x**  
**39**

# JL Tire Clearance Guide (FACTORY FENDERS)

By limiting suspension up travel, TeraFlex Bump Stops allow the use of larger tires while keeping the factory fenders.

JL Rubicon models feature high-clearance fenders that allow for more up travel, while the lower-clearance fenders on JL Sport and Sahara restricts tire size due to fender rubbing.

In order to address these fender differences, TeraFlex designed a proprietary modular bump stop system, which can be added to fit several different lift height and tire size configurations.

In addition to the main 2" bump stop spacers, this system includes multiple 0.5" interlocking spacers that can be added to fine tune bump stop height to limit suspension up travel.

JL RUBICON

## JL Rubicon with Factory Fenders:

*See Notes: Not all Tires Measure the Same*

- 33" - No Bump Stops
- 35" - 2" Front & 2" Rear Bump Stops



- 37" - 2.5" Front & 3" Rear Bump Stops

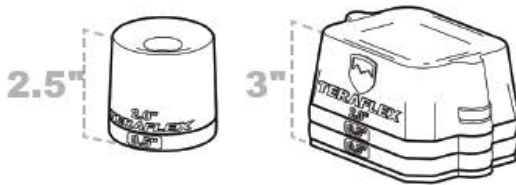

JL SPORT/SAHARA

## JL Sport/Sahara with Factory Fenders:

*See Notes: Not all Tires Measure the Same*

- 33" - No Bump Stops
- 35" - 3" Front & 2.5" Rear Bump Stops

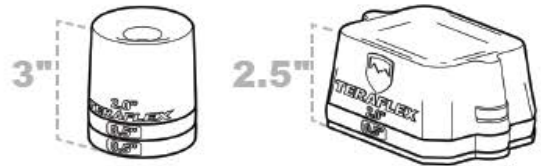

- 37" - 3.5" Front & 4" Rear Bump Stops

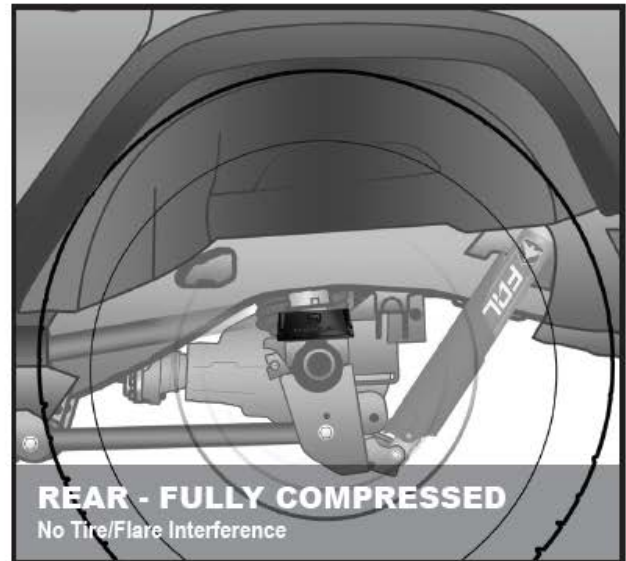
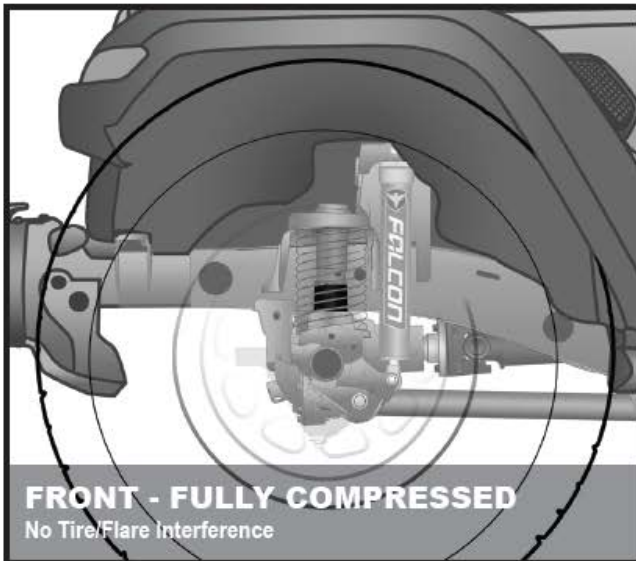
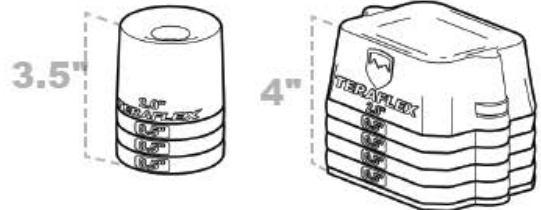

## 2-4 Inch Shock Options

### JL Falcon Adjustable PiggyBack Shocks

- 4 Door Series 3.3, 11-01-33-400-200-3
- 2 Door Series 3.3, 10-01-33-400-200-3

- \*Fast Adjust Knob
- \*High Flow Oil Channel
- \*Offset Sleeve Design
- \*PiggyBack Reservoir

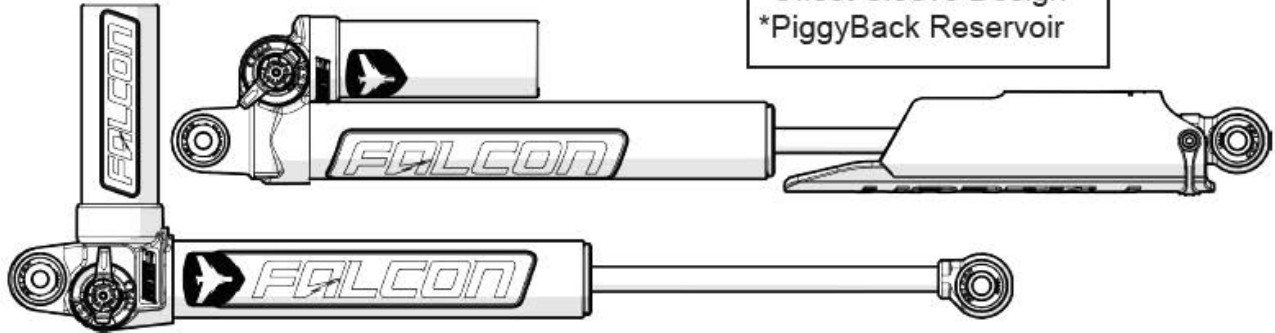

### JL Falcon PiggyBack Shocks

- 4 Door Series 3.1, 11-01-31-400-200-3
- 2 Door Series 3.1, 10-01-31-400-200-3

- \*Series 3.3 Upgradable
- \*High Flow Oil Channel
- \*Offset Sleeve Design
- \*PiggyBack Reservoir

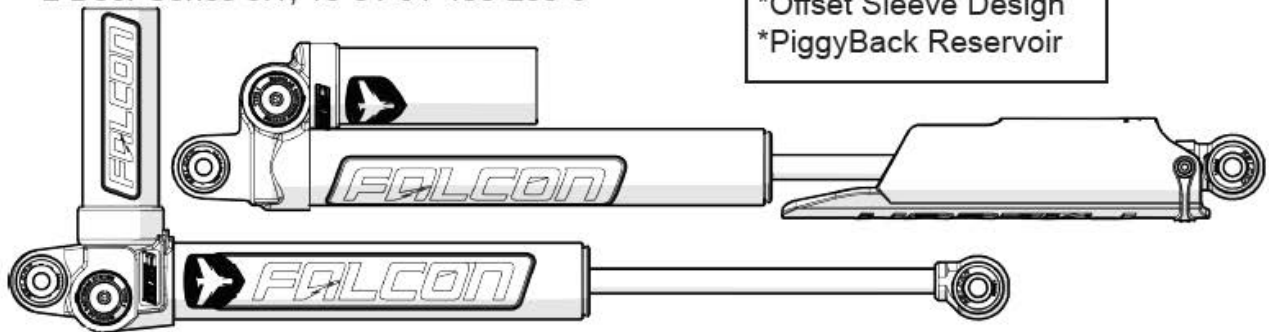

### JL Falcon Monotube Shocks

- 4 Door Series 2.1, 11-01-21-400-200-3
- 2 Door Series 2.1, 10-01-21-400-200-3

- \*Oil Gas Separator
- \*3/4" Chrome Shaft
- \*Offset Sleeve Design
- \*JL Specific Shock

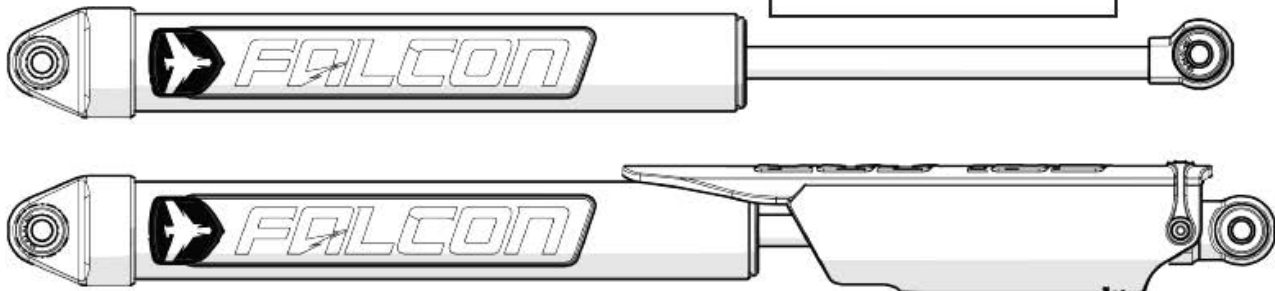



# Jeep JL 9550 Shock Install

# 1545000 JL 0"-1.5"

# 1545250 JL 2"- 4.5"

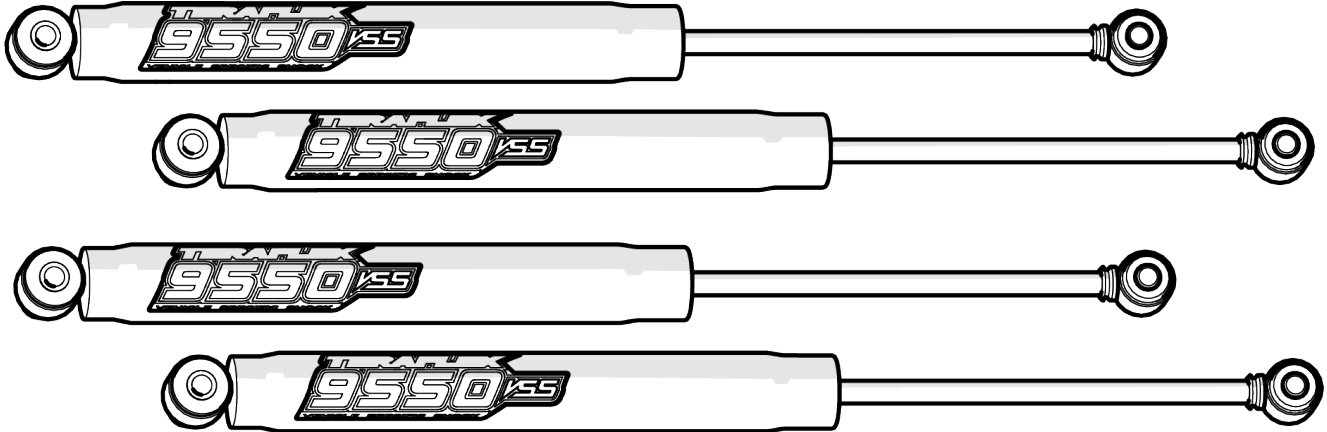

## Important Notes:

Prior to beginning this install, or any installation, read the instructions thoroughly to familiarize yourself with the required steps. Evaluate if you are experienced and capable to personally perform these modifications. A factory service manual should be used in conjunction with these installation instructions.

This product will change the highway handling characteristics of your vehicle, exercise caution. After altering the suspension it is always advisable to have an alignment done by a competent 4 wheel drive shop or by an alignment shop that is experienced with lifted 4 wheel drive vehicles.

Refer to the parts list to ensure that all necessary components and hardware has been included. If any parts are missing please contact your local TeraFlex dealer for assistance.

**When reinstalling OEM hardware, refer to the torque specs given in the Factory Service Manual.**

---

## Tools Needed:

- Metric Sockets and Open End Wrenches
- Torque Wrench

- Factory Service Manual
- General Mechanics Tools

---

## Maintenance Note:

After the first 300 miles and every 3,000 miles after that, re-torque all the suspension components and bolts.



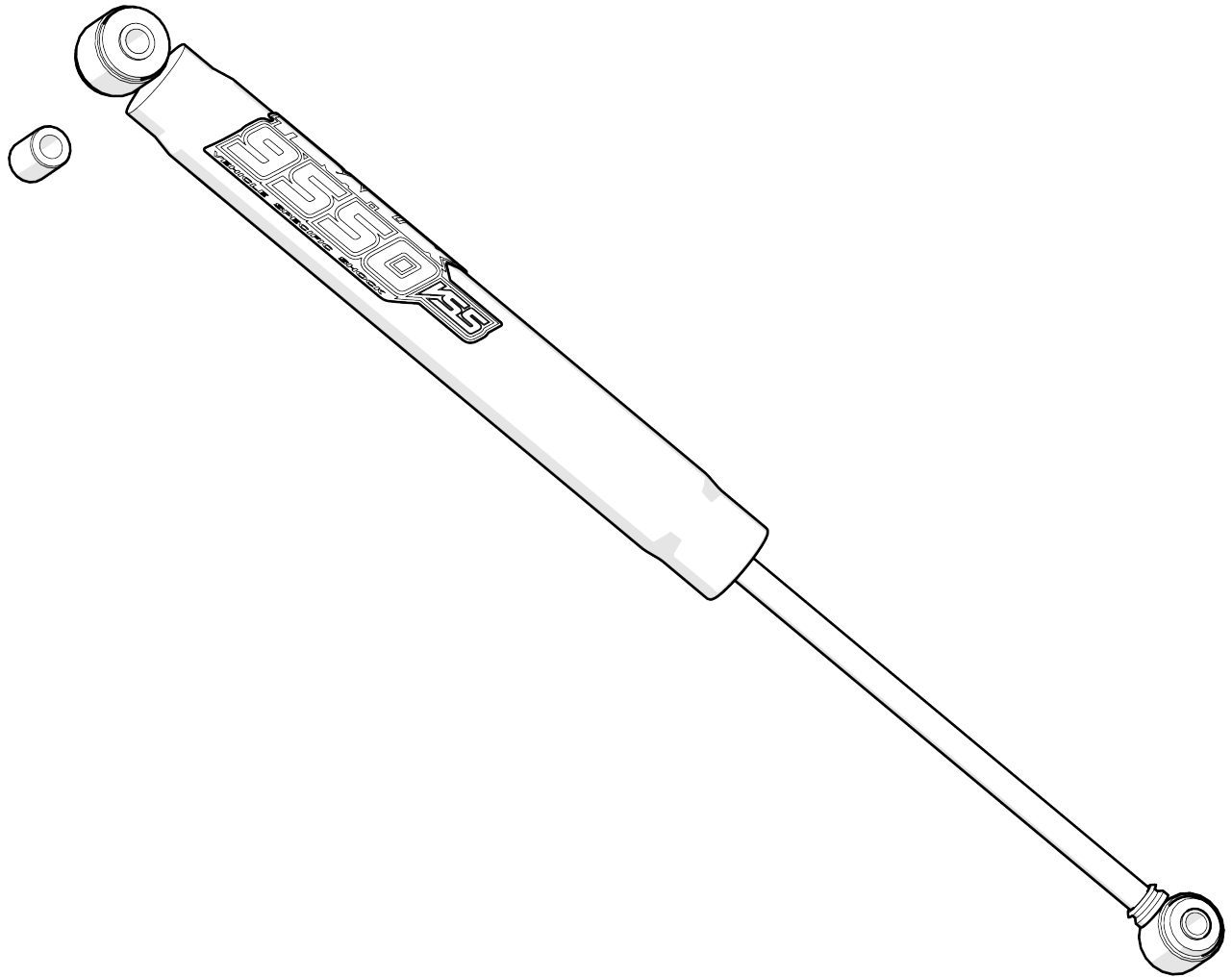

**NOTE: THIS INSTALLATION CAN BE DONE WITHOUT LIFTING THE JEEP. IF YOU CHOOSE TO LIFT THE JEEP, REFER TO YOUR OWNERS MANUAL FOR SAFE LIFTING LOCATIONS AND PROCEDURES.**

### REMOVE THE FRONT SHOCK

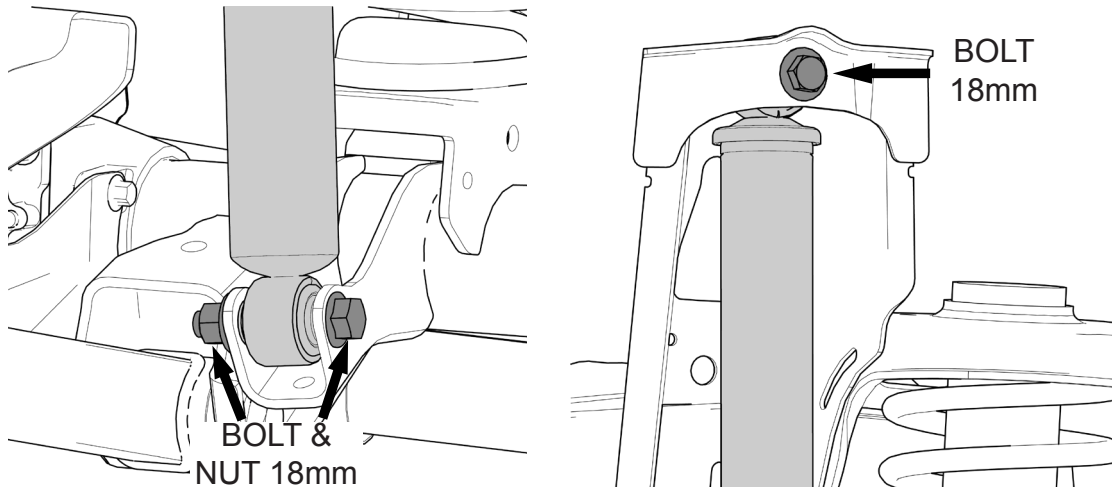

1

### INSTALL THE NEW SHOCK AND SPACER ONTO THE FRAME

**NOTE: INSTALL THE SPACER IN BETWEEN THE FRAME AND SHOCK. REINSTALL THE FACTORY HARDWARE.**

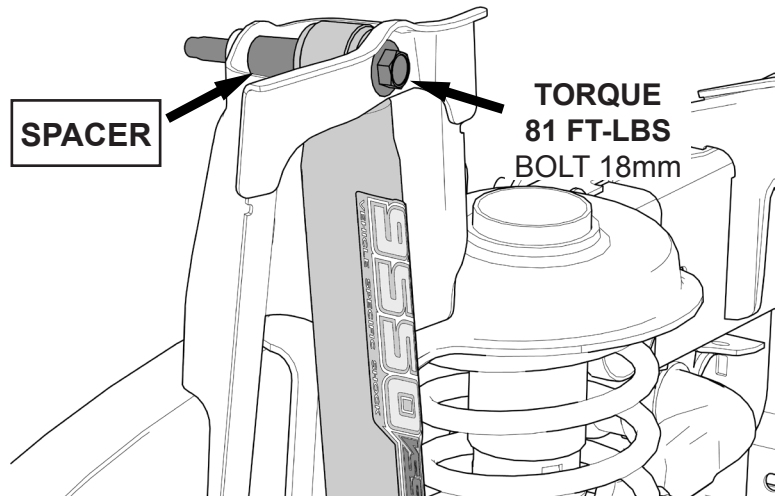

2

### INSTALL THE NEW SHOCK ONTO THE AXLE

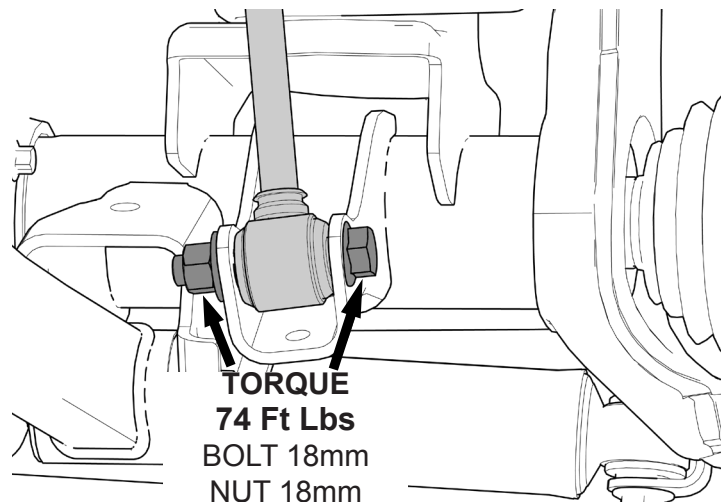

3

### REMOVE THE REAR SHOCK

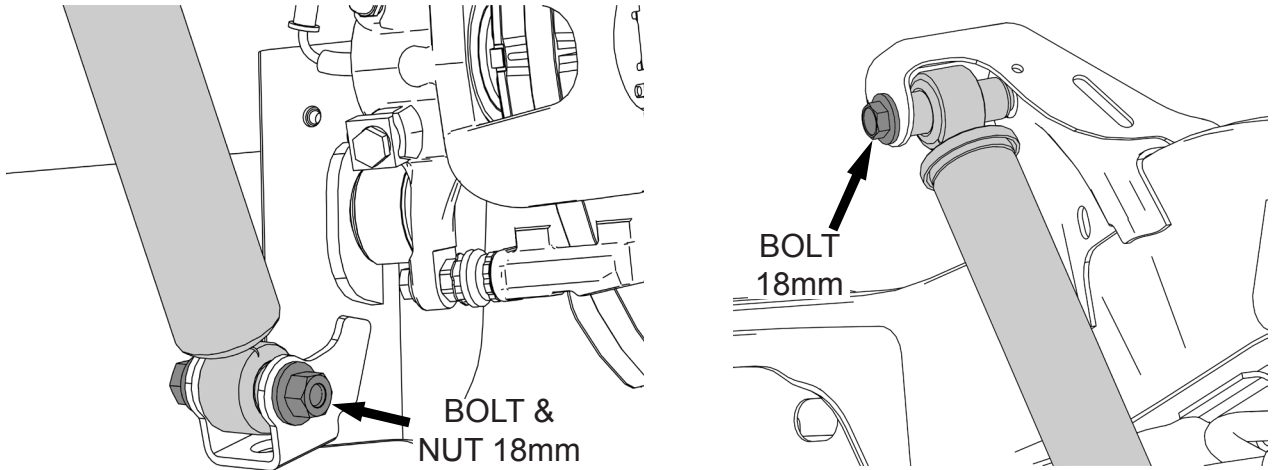

### INSTALL THE NEW SHOCK AND SPACER ONTO THE FRAME

**NOTE: INSTALL THE SPACER IN BETWEEN THE FRAME AND SHOCK. REINSTALL THE FACTORY HARDWARE.**

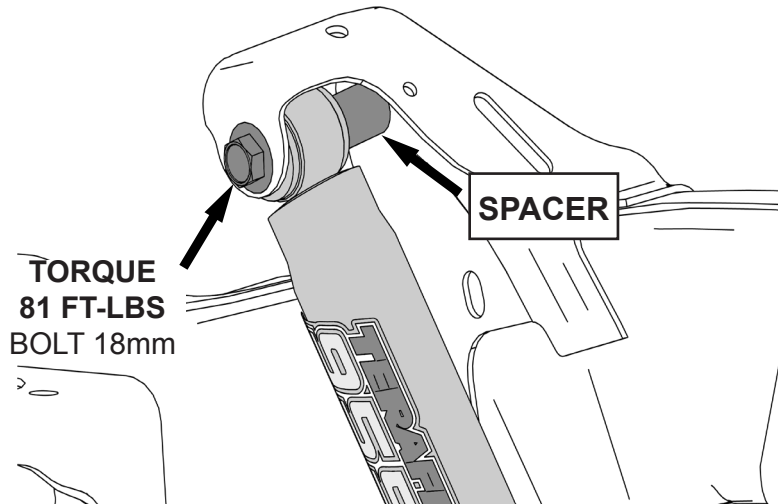

### INSTALL THE NEW SHOCK ONTO THE AXLE

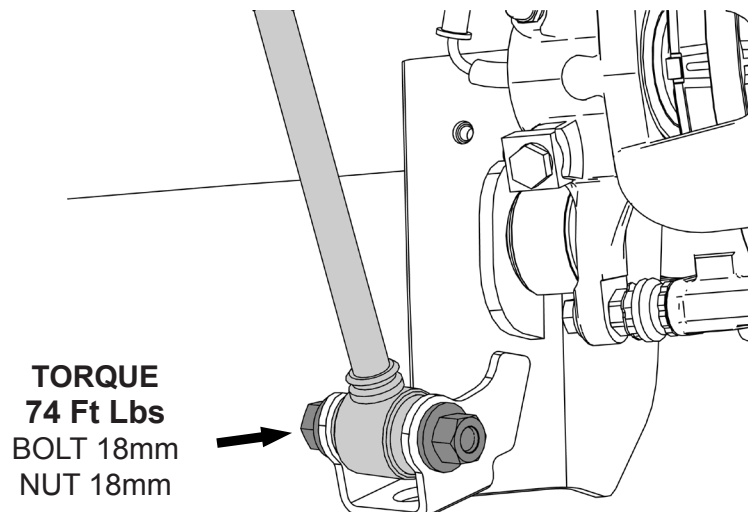

# ***TERAFLEX***

## **PRODUCT INFORMATION**

### **MAINTENANCE INFORMATION:**

It is the buyer's responsibility to have all suspension, drivetrain, steering, and other components checked for proper tightness and torque after the first 100 miles and every 3000 miles after that.

### **NOTICE TO INSTALLER:**

The enclosed "Warning to Driver" sticker must be installed in the vehicle in driver's view. This sticker is to act as a constant safety reminder when operating the vehicle. It is your responsibility as the equipment installer to install the provided sticker and to forward the product instructions to the vehicle's owner for review. If a "Warning to Driver" sticker or product installation guide were not included in the kit, FREE replacement stickers and instructions are available by request. It is the installer's duty to ensure a safe and controllable vehicle after the modifications have been performed.

### **WARNING:**

Neither the seller nor the manufacturer will be liable for any loss, damage, or injury directly or indirectly arising from the use of or inability to determine the use of these products. Before using, the user shall determine the suitability of the products for its intended use, and the user shall assume all re-sponsibility and risk in connection therewith.

### **WARNING TO DRIVER:**

This vehicle has been modified to enhance off road performance and has unique handling characteristics. Use in harsh environments can cause extreme stress on the components. Vehicle should be inspected after being off road to make sure that all the components are in working order and safe to travel on the highway. All fasteners should be checked so that they are at the correct torque specifications as the vibration and stresses from off roading may cause critical fasteners to work loose. Extra care should be taken to inspect the critical components, steering, and brake systems. During each oil change components such as arms, tie rod ends, etc should be greased and checked for excessive wear. Any worn components should be replaced. When returning to the pavement always set or restore tire air pressure to the factory recommendation and connect or engage any disabled sway bar mechanisms. Because of the higher center of gravity and larger tires, this vehicle handles and reacts differently than many passenger cars, both on and off road. You must drive it safely! Extreme care should be taken to prevent vehicle rollover or loss of control, which can result in serious injury or death. Avoid sudden sharp turns or abrupt maneuvers. Generally, braking performance and capabilities are decreased when significantly larger/heavier tires are used, especially when used in combination with transfer case low-range reduction kits. Take this into consideration while driving. Do not add, alter or fabricate any factory or aftermarket parts to increase vehicle height over the intended height of the TeraFlex product purchased. Mixing component brand is not recommended. TeraFlex Inc. will not be responsible for any altered product or any improper installation or use of our products. We will be happy to answer any questions concerning the design, function, and correct use of our products. It is ultimately the buyer's responsibility to have all bolts/nuts checked for tightness after the first 100 miles and then every 3000 miles. Wheel alignment, steering system, suspension and drive line systems must be inspected by a qualified professional mechanic at least every 3000 miles.