

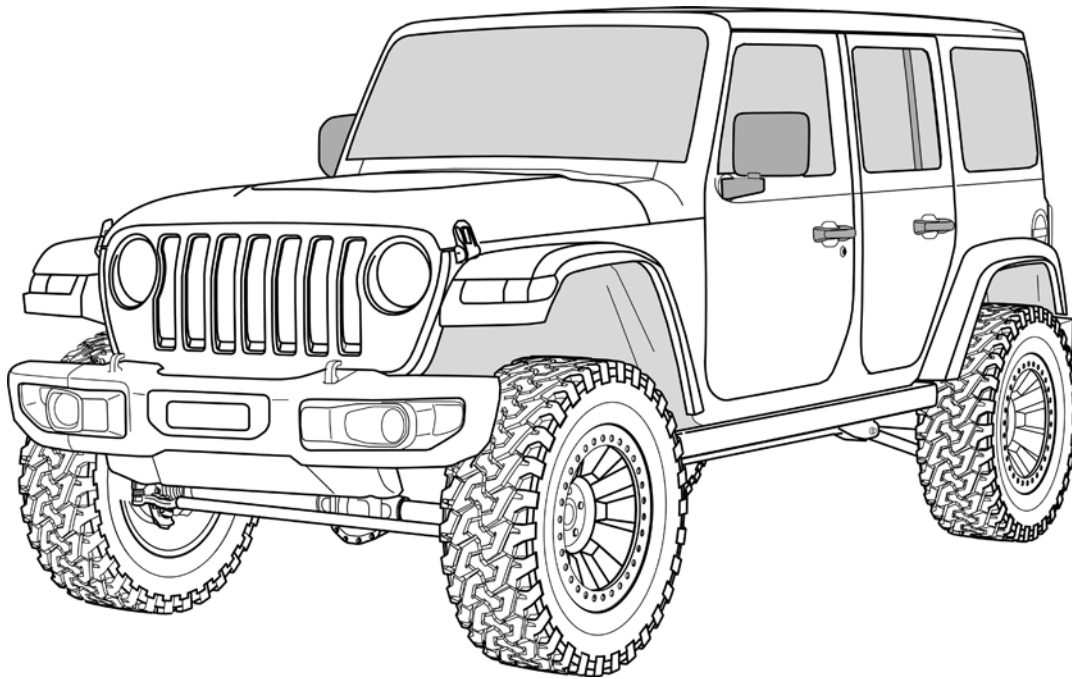

# Jeep JL 3.5" Spring Lift



## Important Notes:

Prior to beginning this install, or any installation, read the instructions thoroughly to familiarize yourself with the required steps. Evaluate if you are experienced and capable to personally perform these modifications. A factory service manual should be used in conjunction with these installation instructions.

This product will change the highway handling characteristics of your vehicle, exercise caution. After altering the suspension it is always advisable to have an alignment done by a competent 4 wheel drive shop or by an alignment shop that is experienced with lifted 4 wheel drive vehicles.

Refer to the parts list to ensure that all necessary components and hardware has been included.

**If a 37" tire is being installed on a Sport or Sahara additional up travel limit may be required using Bumpstop Spacer Kit #1959300.**

---

## Tools Needed:

- Metric Sockets and Open End Wrenches
- Torque Wrench













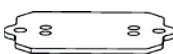
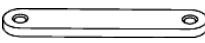

- Factory Service Manual
- General Mechanics Tools

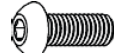

---

## Maintenance Note:

After the first 300 miles and every 3,000 miles after that, re-torque all the suspension components and bolts.

Spring Box Components

	Description	Item #	Alpine CT3		Sport ST3		Base Spring Lift	
			4DR	2DR	4DR	2DR	4DR	2DR
	1 Front	02-21-401-250-1	2	-	2	-	2	-
		02-21-201-250-1	-	2	-	2	-	2
	2 Rear Left	02-22-411-250-1	1	-	1	-	1	-
		02-22-211-250-1	-	1	-	1	-	1
	3 Rear Right	02-22-421-250-1	1	-	1	-	1	-
		02-22-221-250-1	-	1	-	1	-	1
	4 Front Bumpstops	12-01-109-200	2	2	2	2	2	2
	5 Rear Bumpstops	12-01-209-200	2	2	2	2	2	2
	6 Rear Bumpstop Bracket	12-02-209-002	2	2	2	2	2	2
	7 Rear Bumpstop Mounting Strap	12-02-209-001	2	2	2	2	2	2
	8 Front Bumpstop Spacers	12-02-109-050	4	4	4	4	4	4
	9 Rear Bumpstop Spacers	12-02-209-050	4	4	4	4	4	4
	10 Brake Line Anchor Kit	1101255	1	1	1	1	1	1
	11 Front Swaybar link 10.75"	744500	2	2	2	2	2	2
	12 Rear Swaybar Link 11.50	21-01-001-115	2	2	2	2	2	2
	13 M10 x 1.5 Fuji Nut	23-07-03-001	6	6	6	6	6	6
	14 M10 x 1.5 x 100mm Flat Socket Cap Screw	45-04-003-001	2	2	2	2	2	2
	15 M10 x 1.5 x 50mm Socket Cap Screw	45-03-003-001	4	4	4	4	4	4
	16 M10 x 1.5 x 25mm Button Socket Cap Screw	45-05-003-003	4	4	4	4	4	4
	17 M10 Lock Washer	45-12-002-001	4	4	4	4	4	4
	18 Nut Wrench Tool	600271	1	1	1	1	1	1
	19 M12 x 1.75 x 55mm Button Socket Cap Screw	45-05-003-001	2	2	2	2	2	2
	20 M12 x 1.75mm Black Fuji Nut	23-07-02-002	2	2	2	2	2	2

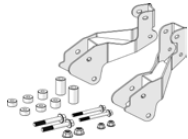
	Other Boxed Kits	Description	Item #	Alpine CT3		Sport ST3		Base Spring Lift	
				4DR	2DR	4DR	2DR	4DR	2DR
					Jounce Bumpers Kit	1959200	1	1	1
	Alpine Control Arm Kit	1416510	1	1	-	-	-	-	
	Front Arm Drop Bracket Kit	1938125	-	-	1	1	-	-	

Note: If installing Alpine Control Arm Kit Refer to Instruction #999321 before continuing.

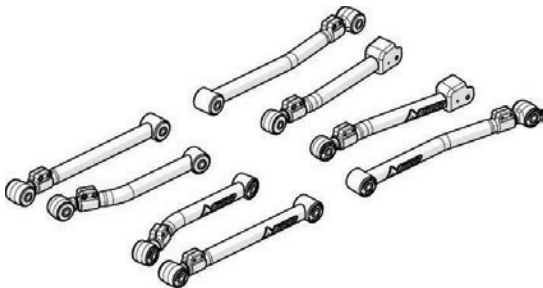

Note: If installing Front Drop Bracket Kit Refer to Instruction #999309 before continuing.

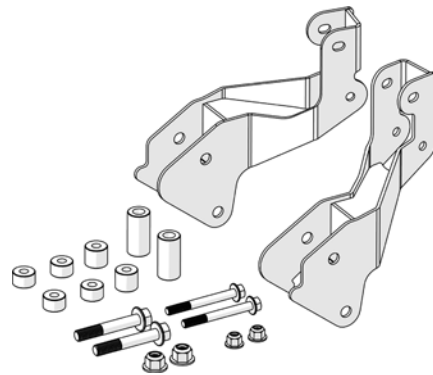

**\*LEAVE CONTROL ARM BOLTS LOOSE UNTIL THE END OF THE LIFT INSTALLATION\***

### FRONT INSTALLATION LIFT AND SUPPORT AT FRAME

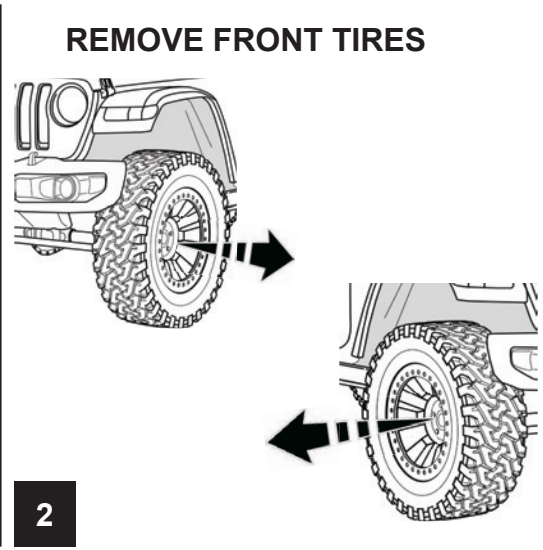
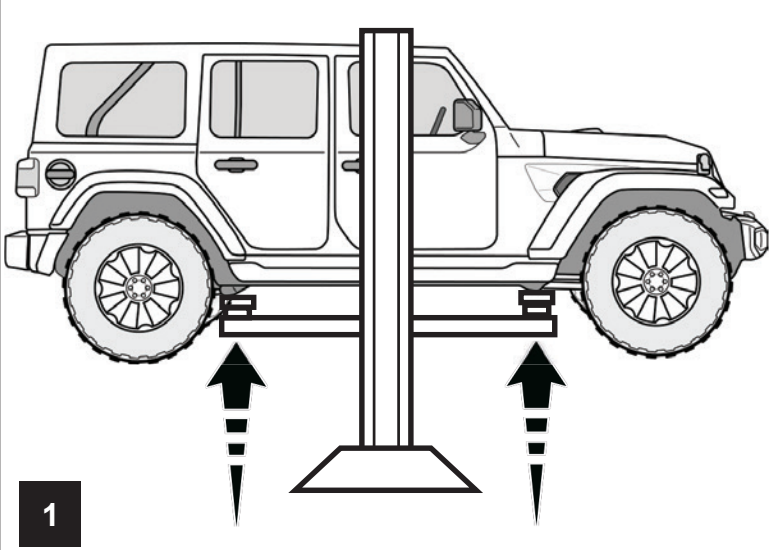
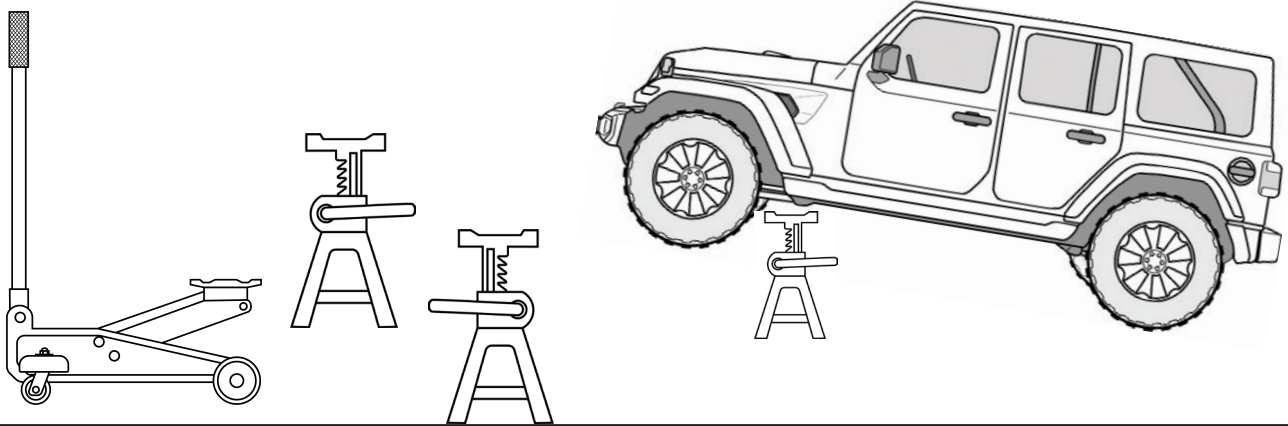

### SUPPORT FRONT AXLE

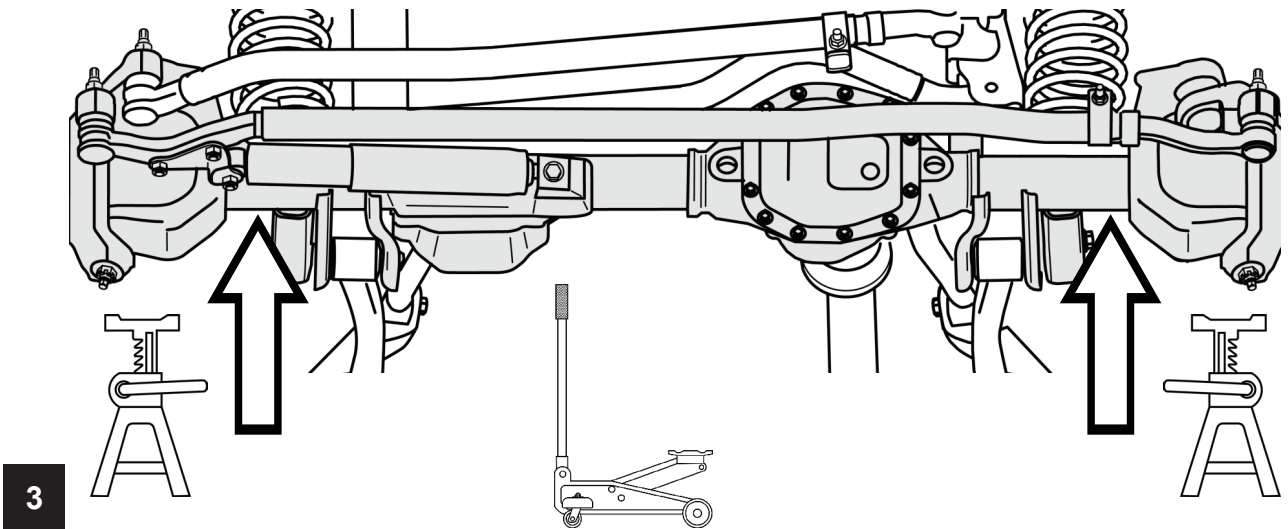

**REMOVE SWAY BAR LINKS & REMOVE TRACK BAR BOLT AT AXLE**

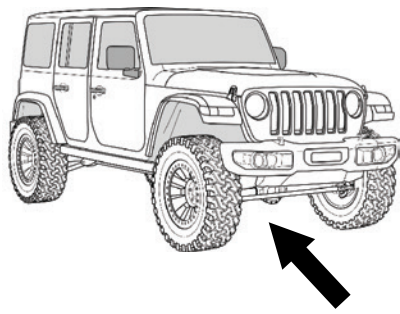

**REMOVE &  
DISCARD**

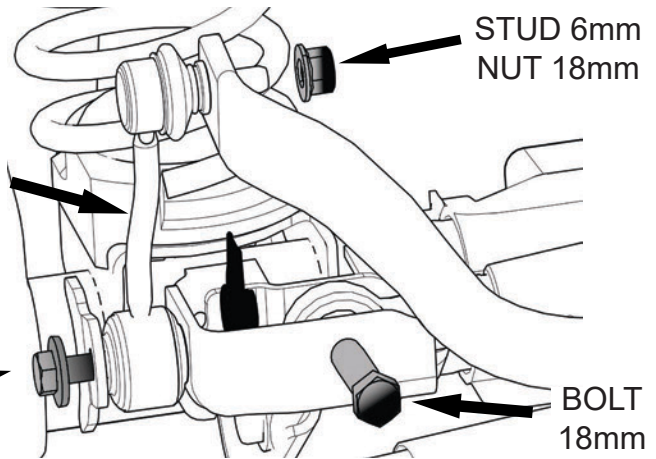

**4**

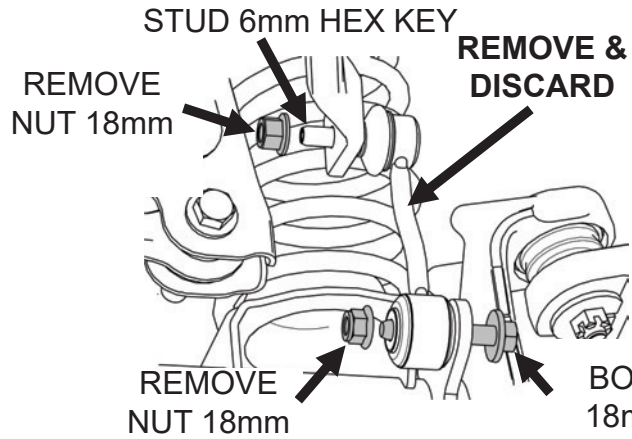
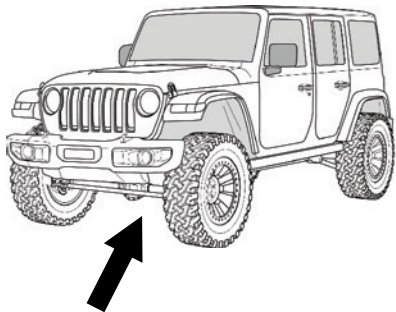

**5**

**REMOVE AND DISCARD BRAKE LINE BRACKETS FROM LOWER CONTROL ARMS**

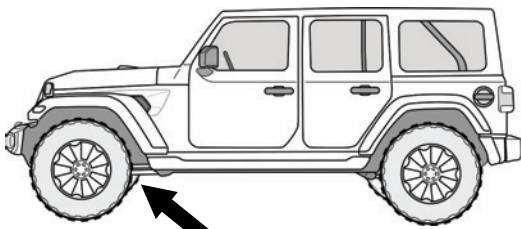
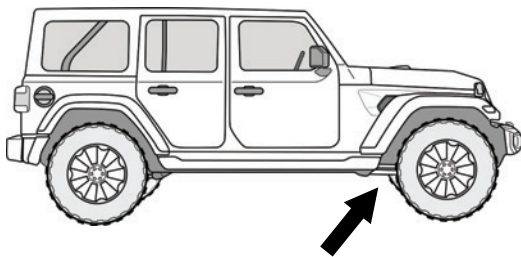

**2X**

**6**

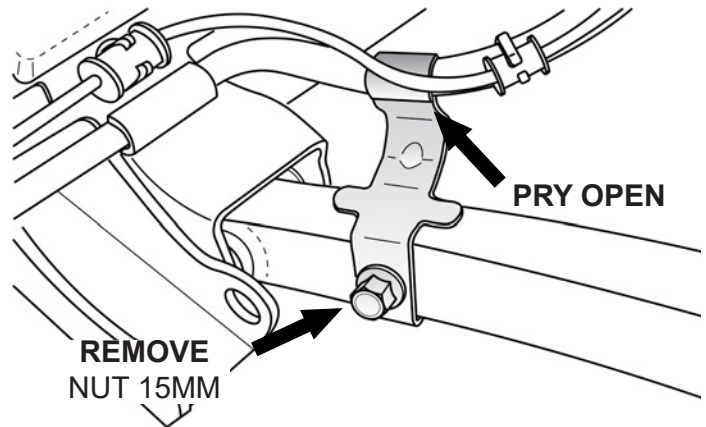

**DISCONNECT ACTUATORS AND VENT HOSE AT THE FRONT AXLE**

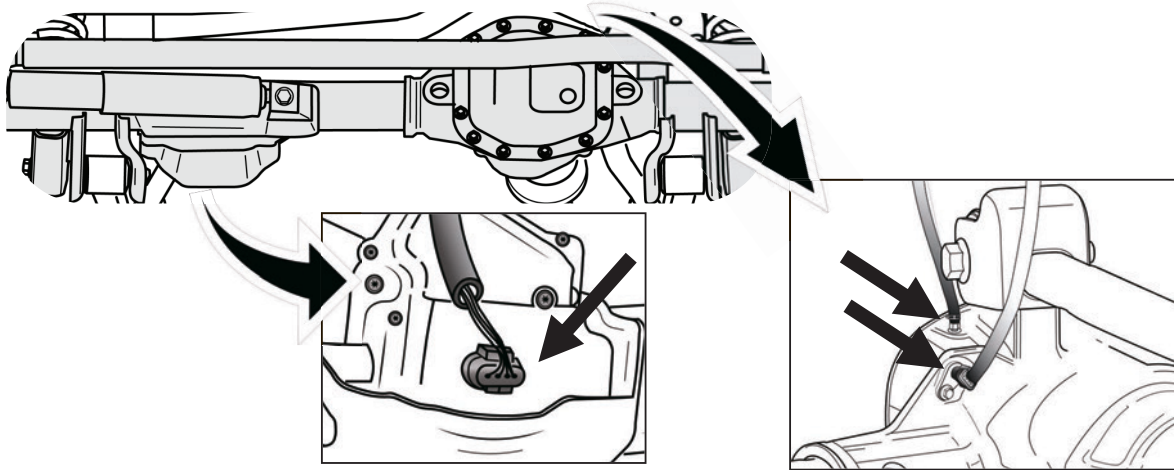

**7**

**LOOSEN FRONT CONTROL ARM BOLTS  
DO NOT REMOVE THE CONTROL ARM BOLTS**

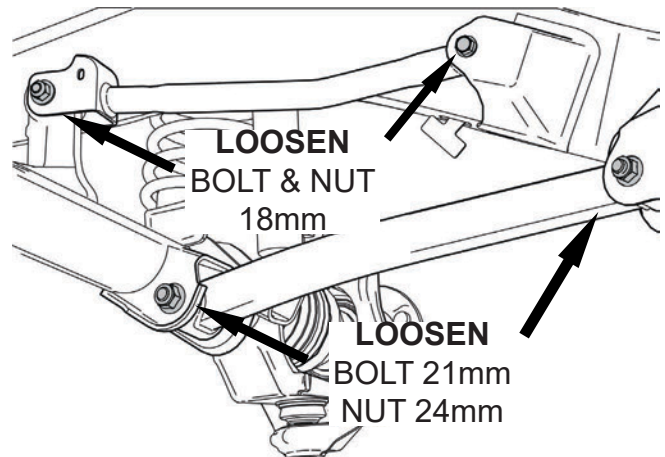
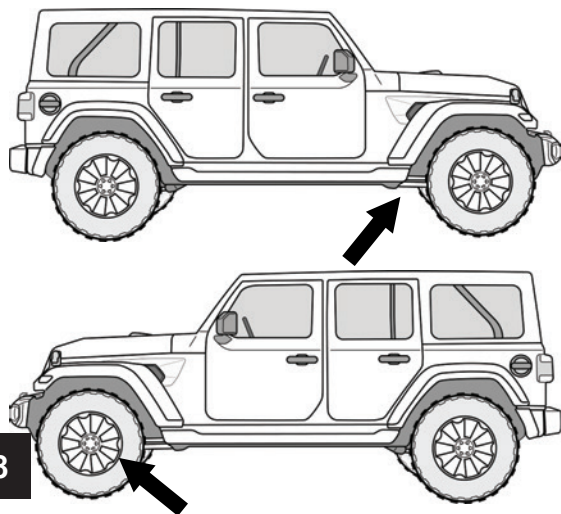

**8**

**REMOVE FRONT SHOCKS**

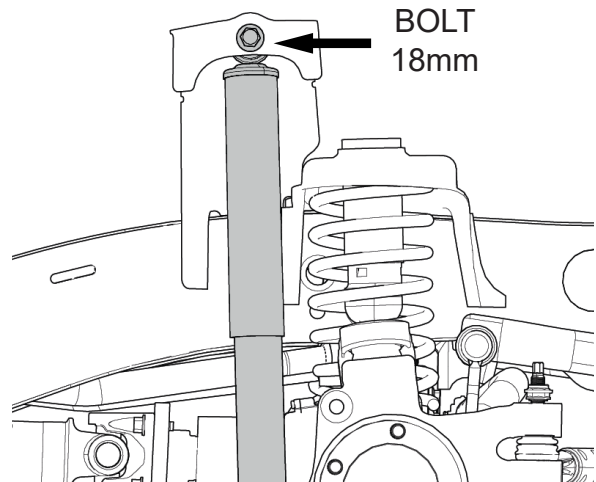
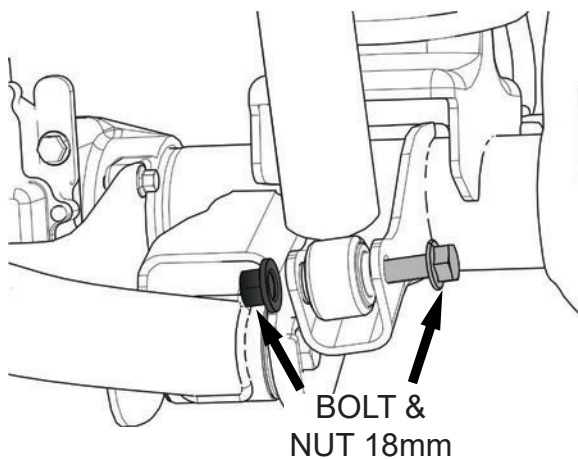

**2X**

**9**

### LOWER AXLE AND REMOVE FRONT SPRINGS

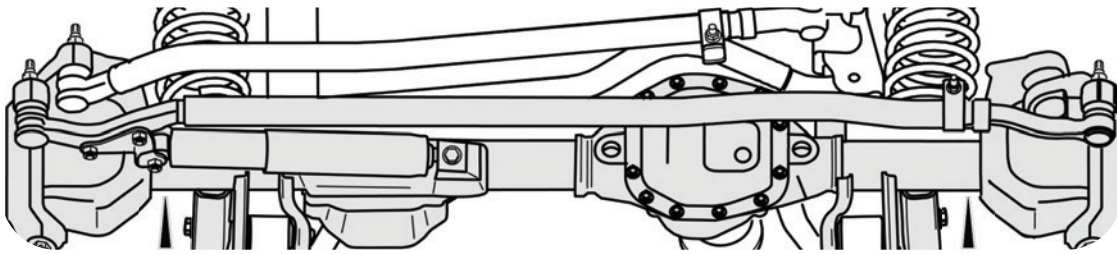

**NOTE: REMOVE ANY PLASTIC RETAINERS FROM WIRING OR HOSES AS NEEDED.**

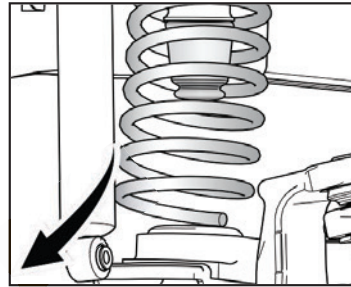

2X

10

**Note: If installing Falcon Jounce Bumpers refer to instruction #999308 before installing springs.**

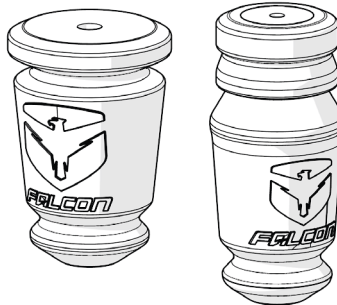

2X

11

### INSTALL BUMPSTOP INTO NEW FRONT SPRING

**TIP: ZIP TIE BUMPSTOP TO SPRING**

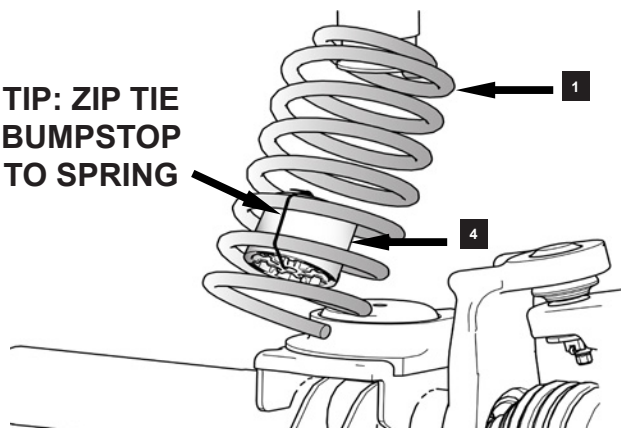

2X

12

**NOTE: REFER TO PAGE 17  
FOR BUMPSTOP SPACER  
GUIDE**

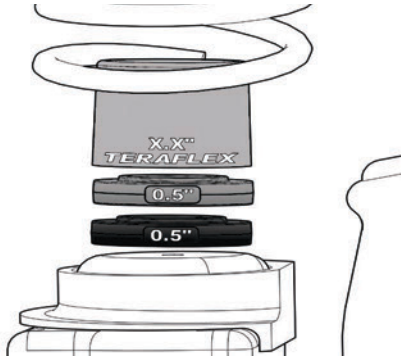

**2X**

**13**

**TORQUE  
12 FT-LBS**

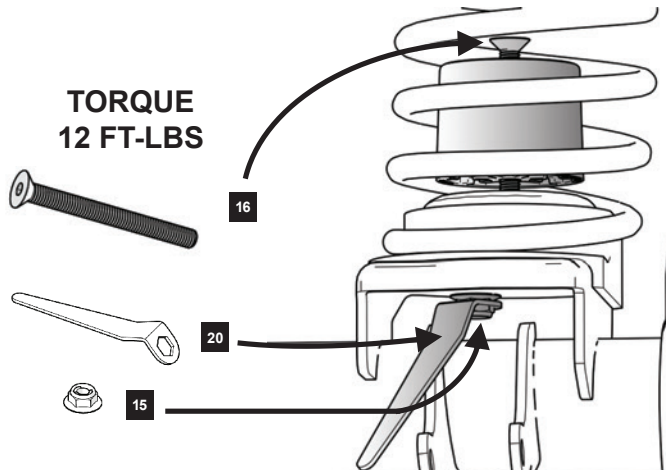

**FULLY SEAT THE SPRINGS INTO THE LOWER SPRING ISOLATOR**

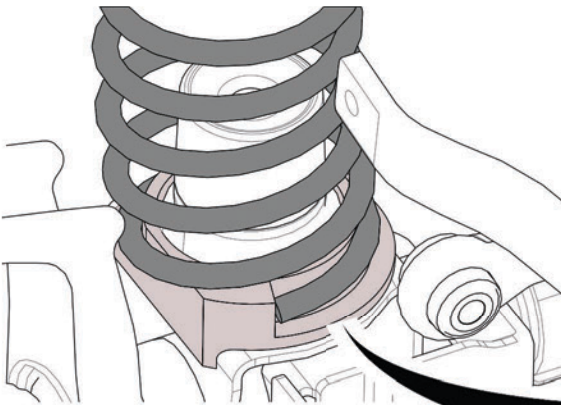

**2X**

**14**

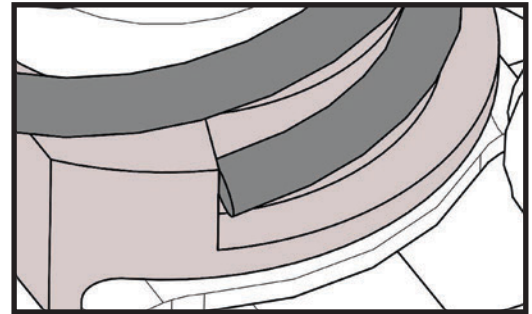

**RAISE AXLE & INSTALL SHOCKS**

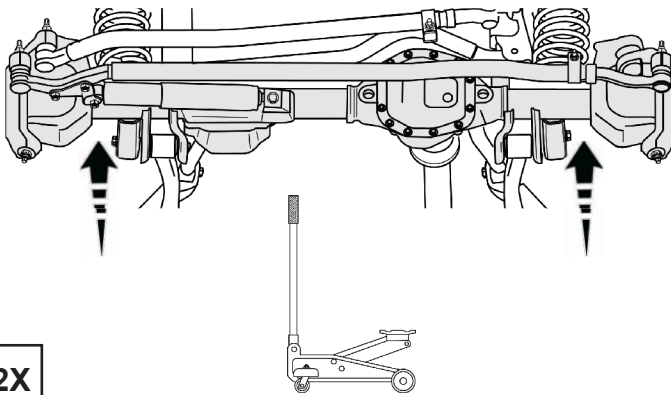

**2X**

**15**

**INSTALL FRONT FALCON SHOCKS AT  
THIS TIME**

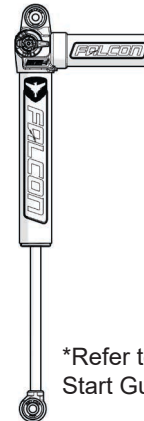

**\*Refer to the Quick  
Start Guide.**



## INSTALL BRAKE LINE ANCHORS

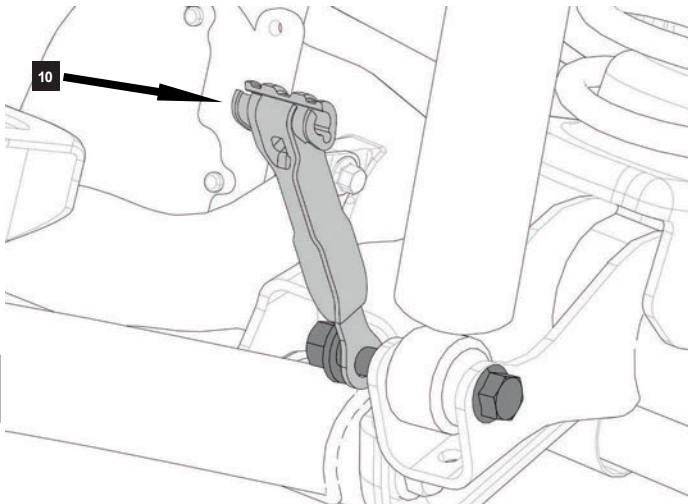

REFER TO THE INSTRUCTIONS ON THE BACK OF THE BRAKE LINE ANCHOR KIT BOX FOR PROPER INSTALLATION.

## INSTALL NEW SWAY BAR LINKS

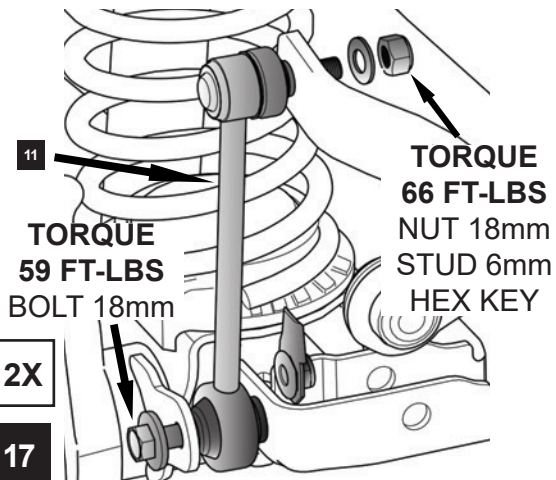

## RECONNECT CONNECTIONS TO FRONT AXLE

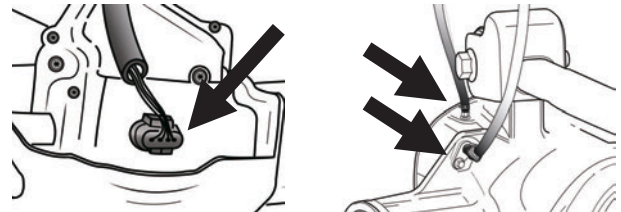

RECONNECT PLASTIC RETAINERS FROM WIRING OR HOSES AS NEEDED.

NOTE: DO NOT TIGHTEN THE CONTROL ARM BOLTS UNTIL THE JEEP IS ON THE GROUND

18 WAIT TO RE-INSTALL TRACK BAR UNTIL THE END OF THE LIFT KIT INSTALL.

NOTE: IF ONLY FRONT OF JEEP WAS LIFTED, REINSTALL TIRES AND LOWER JEEP BACK TO THE GROUND BEFORE LIFTING THE REAR

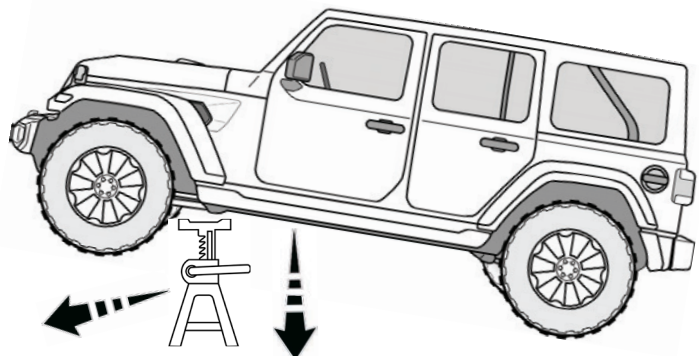
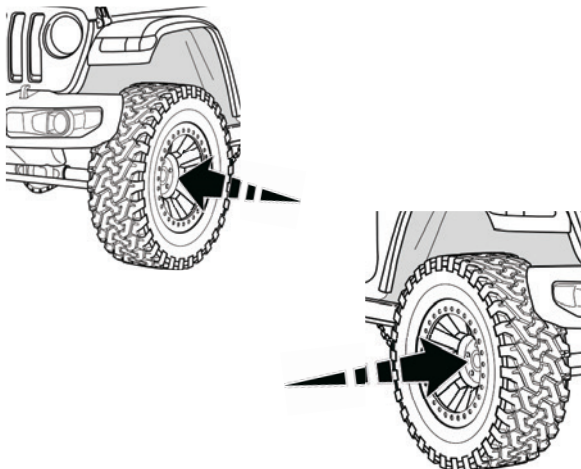

**REAR INSTALL  
LIFT AND SUPPORT AT FRAME**

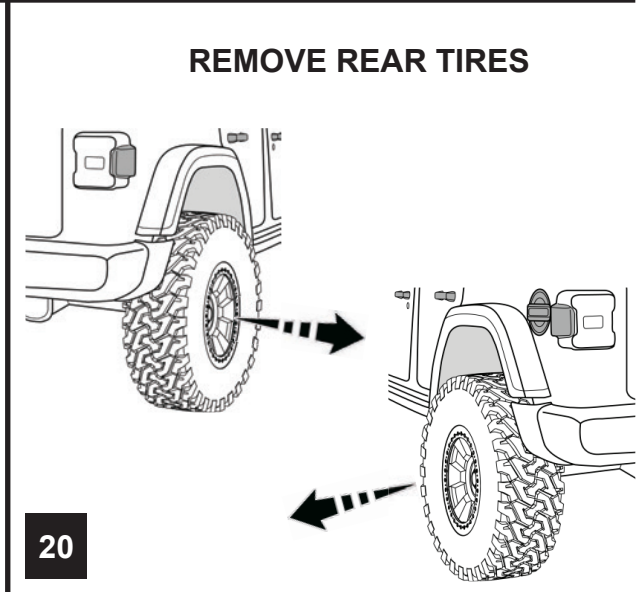
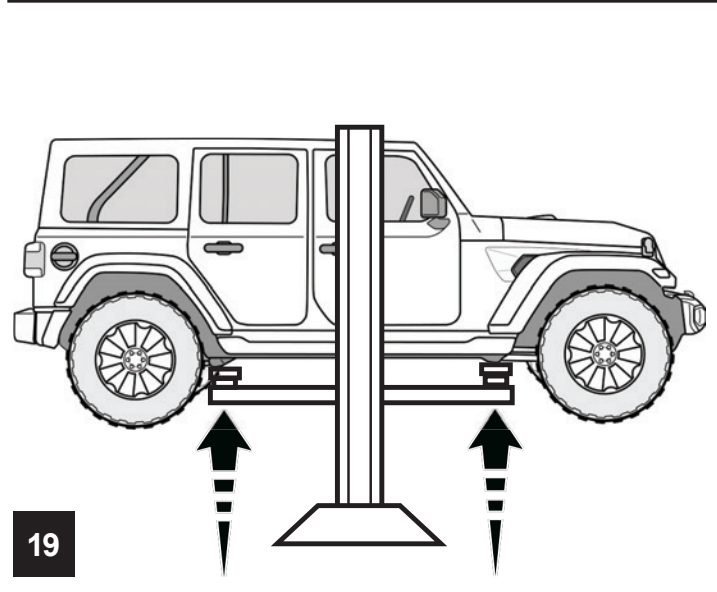
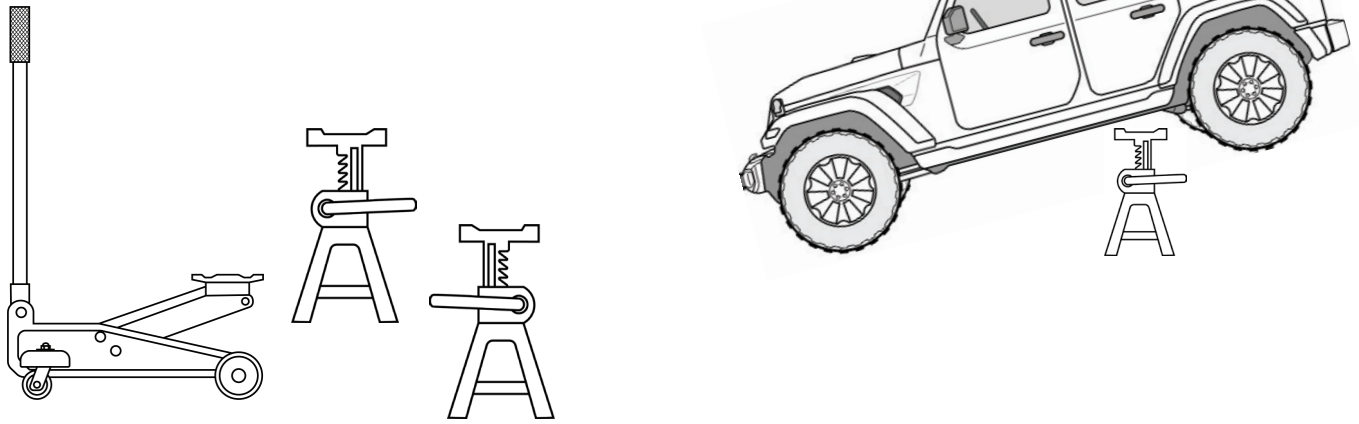

**SUPPORT REAR AXLE**

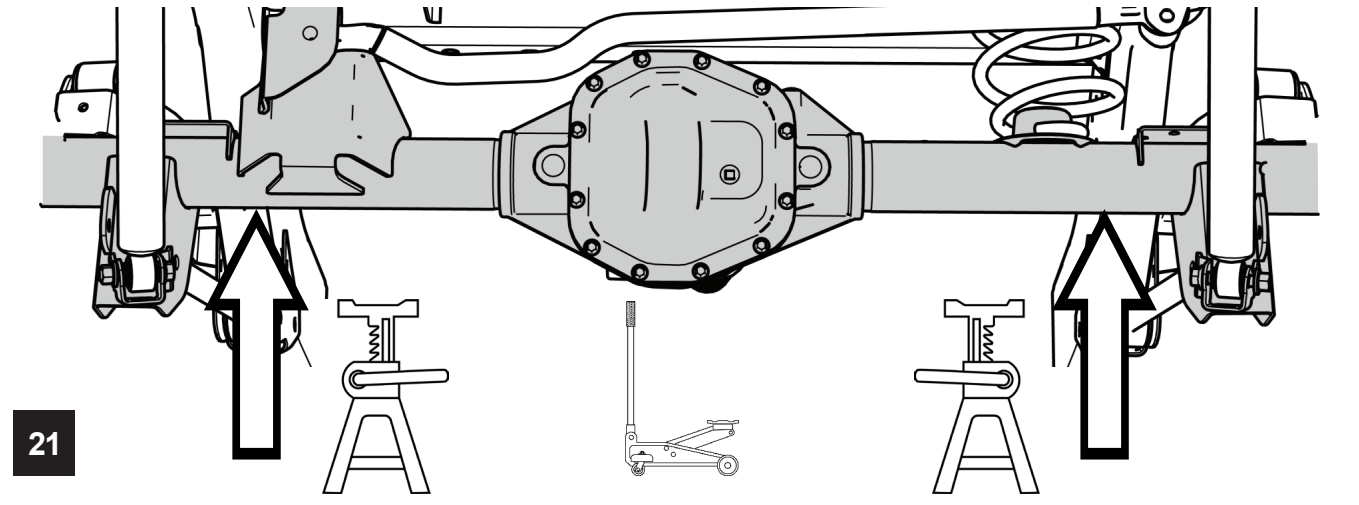

**REMOVE E-BRAKE CABLE BRACKET AND DISCARD**

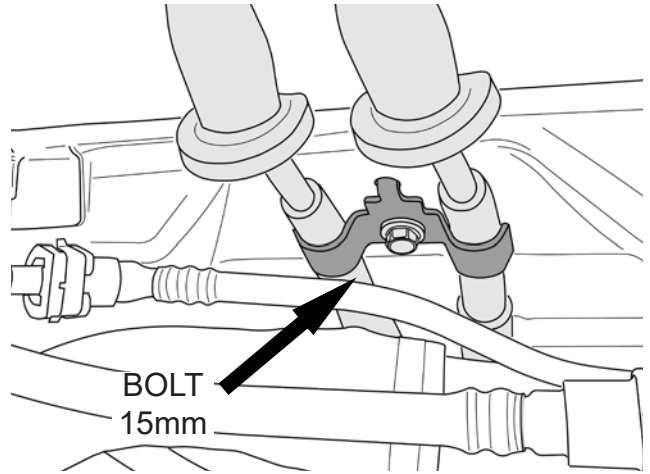
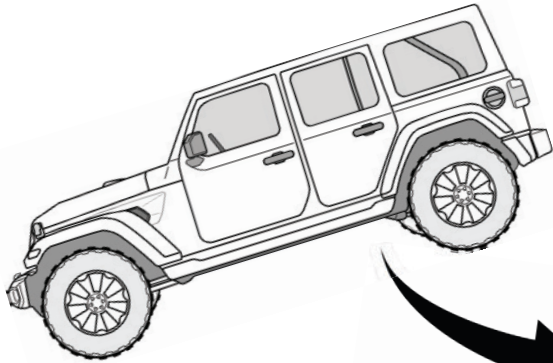

22

**SET THE E-BRAKE AND CLAMP BOTH E-BRAKE EYELETS AGAINST BACKING PLATES WITH LOCKING PLIERS**

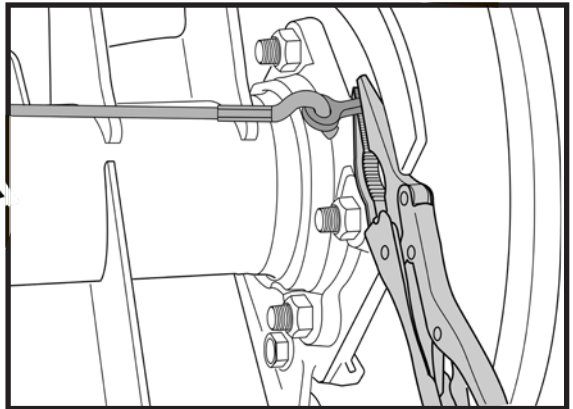
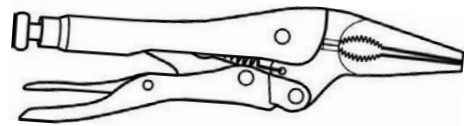
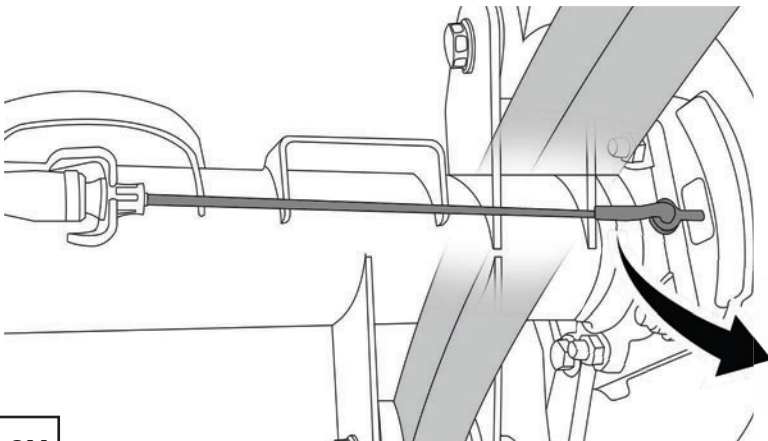

2X

23

**RELEASE E-BRAKE AND DISCONNECT CABLES FROM BOTH EYELETS AND AXLE BRACKETS**

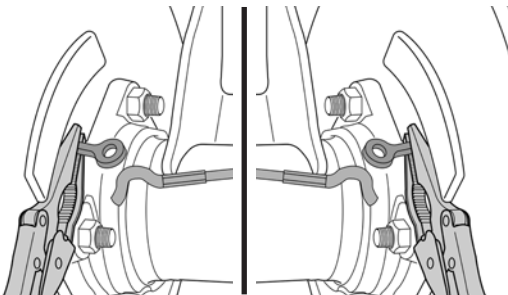

2X

24

**NOTE: DO NOT REMOVE LOCKING PLIERS FROM E-BRAKE EYELETS**

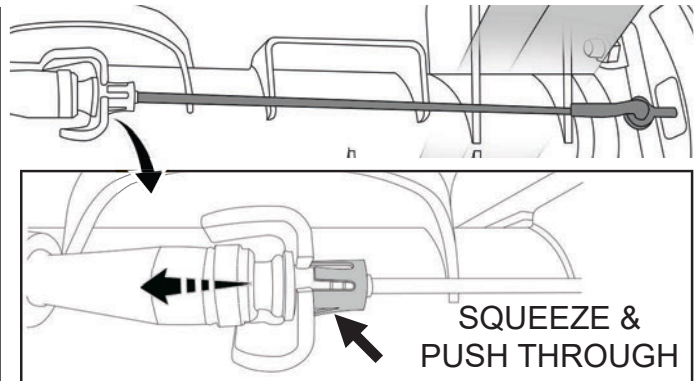

**ROUTE E-BRAKE CABLES UNDER CROSS MEMBER AND FUEL LINES.**

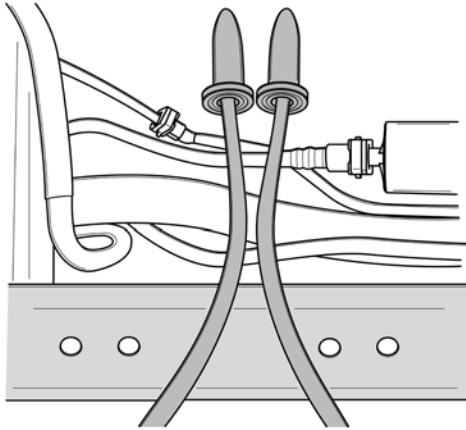

**25**

**RECONNECT E-BRAKE CABLES TO THE AXLE BRACKETS AND THEN THE E-BRAKE EYLETTS.**

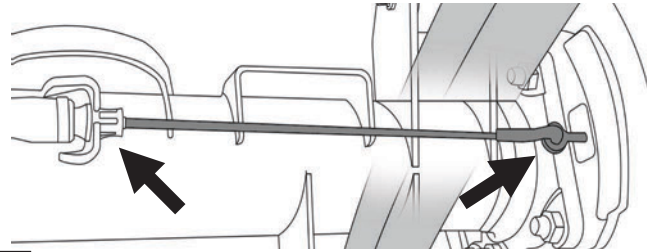

**2X**

**REMOVE PLIERS FROM E-BRAKE EYLETTS**

**26**

**LOOSEN REAR CONTROL ARM BOLTS**

**DO NOT REMOVE THE CONTROL ARM BOLTS**

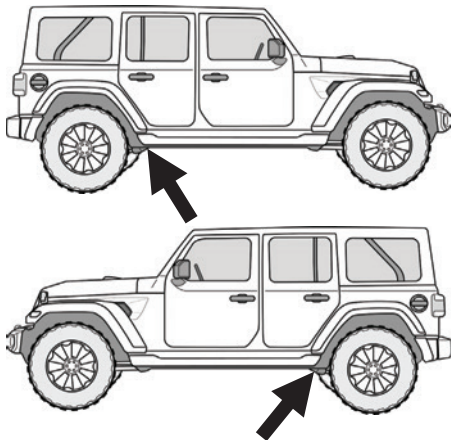

**2X**

**27**

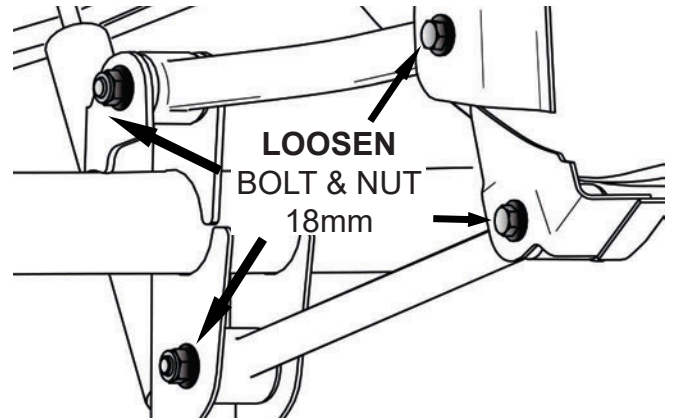

**REMOVE AND DISCARD SWAY BAR LINKS**

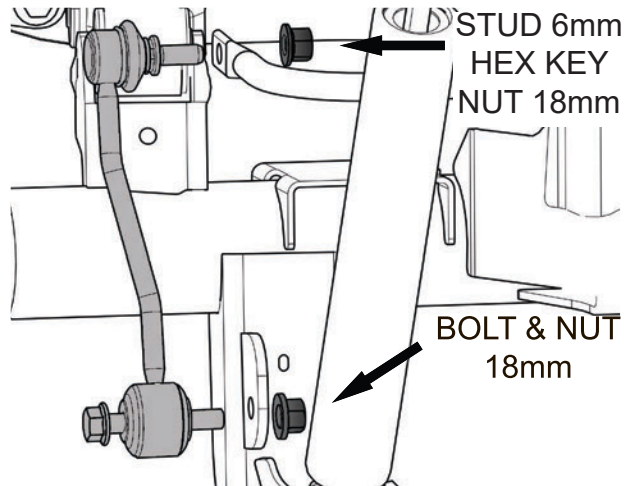

**2X**

**28**

**REMOVE BRAKE LINE BRACKETS FROM BOTH SIDES OF THE AXLE**

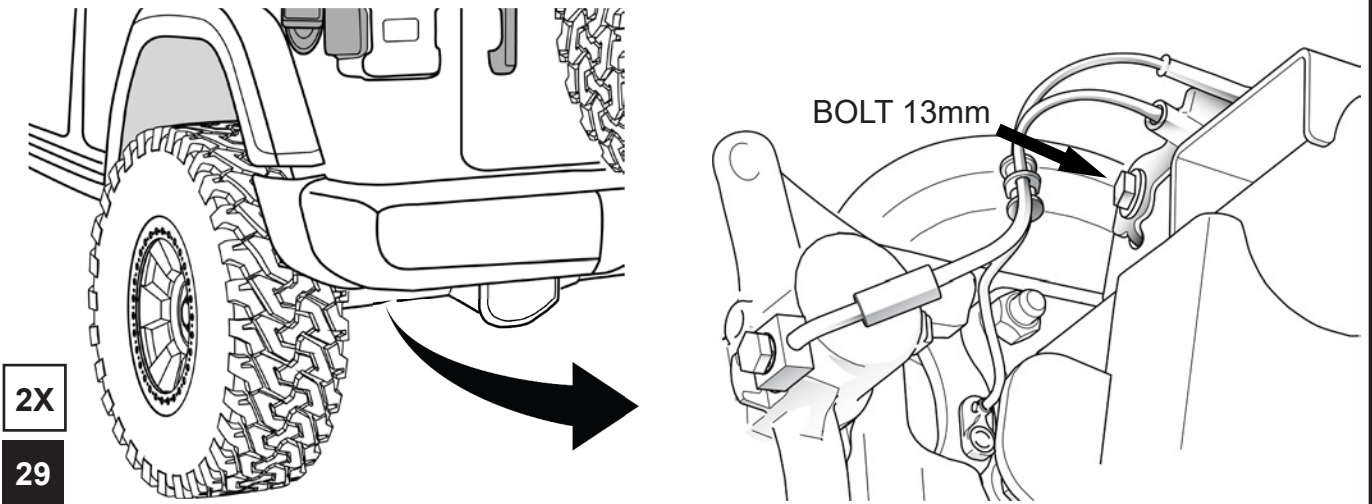

**REMOVE THE TRACK BAR FROM THE AXLE**

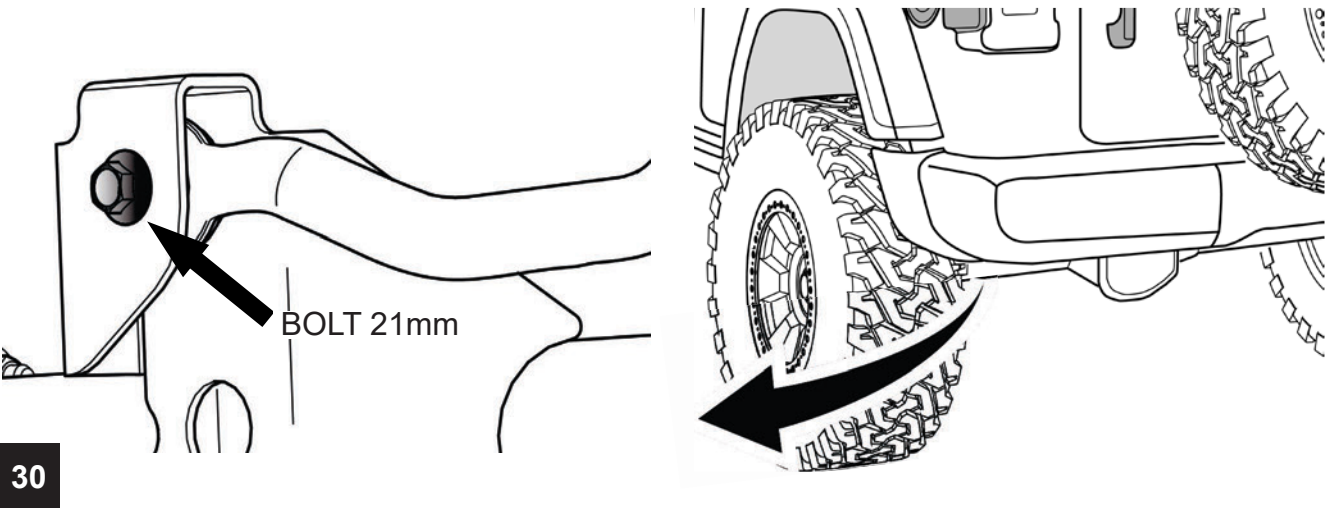

**REMOVE THE REAR SHOCKS**

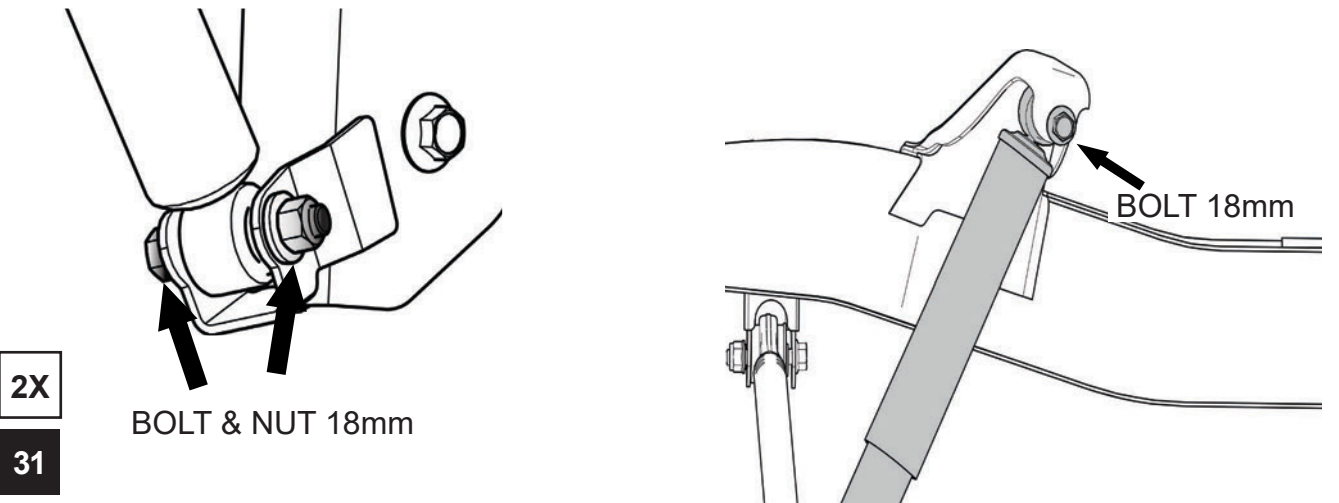

## LOWER AXLE TO REMOVE & DISCARD REAR SPRINGS

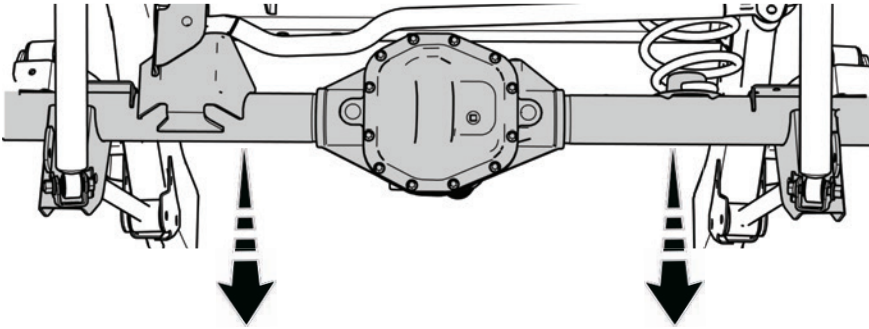

2X

32

**NOTE: REMOVE ANY PLASTIC RETAINERS FROM WIRING OR HOSES AS NEEDED.**

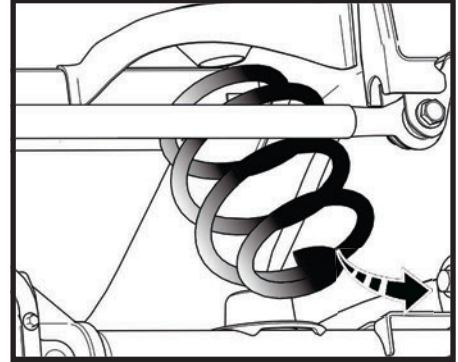

## INSTALL NEW REAR SPRINGS

**INSTALL THE DRIVERS SIDE SPRING FIRST**

**LEFT REAR SPRINGS**  
4 DOOR: 02-22-411-250-1  
2 DOOR: 02-22-211-250-1

**NOTE: PAY SPECIAL ATTENTION TO INSTALL THE CORRECT SPRING ON THE CORRECT SIDE OF THE JEEP. THE REAR SPRINGS ARE SIDE SPECIFIC.**

33

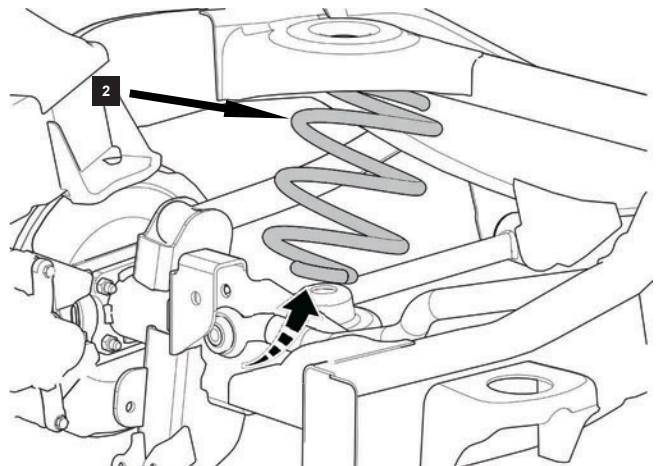

**INSTALL THE PASSENGERS SIDE SPRING**

**RIGHT REAR SPRINGS**  
4 DOOR: 02-22-421-250-1  
2 DOOR: 02-22-221-250-1

2X

34

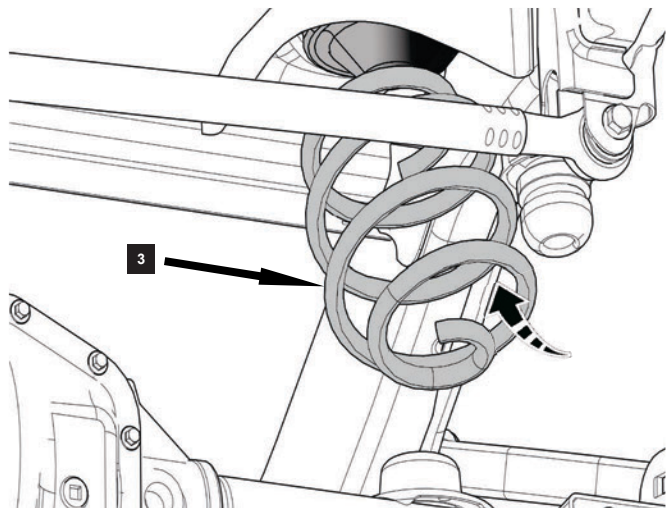

**RAISE THE REAR AXLE AND INSTALL SHOCKS**

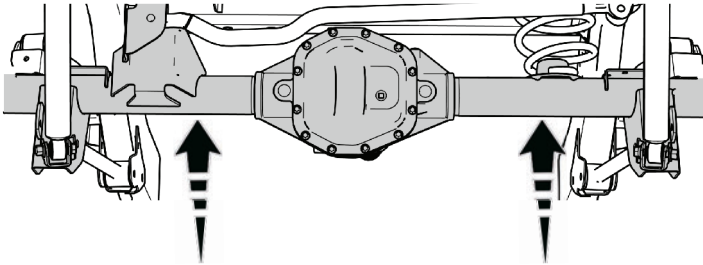

**MAKE SURE TO FULLY SEAT THE SPRINGS INTO THE UPPER SPRING ISOLATOR**

**35**

**INSTALL REAR FALCON SHOCKS AT THIS TIME**

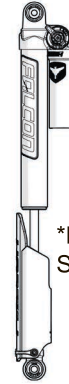

\*Refer to the Quick Start Guide.

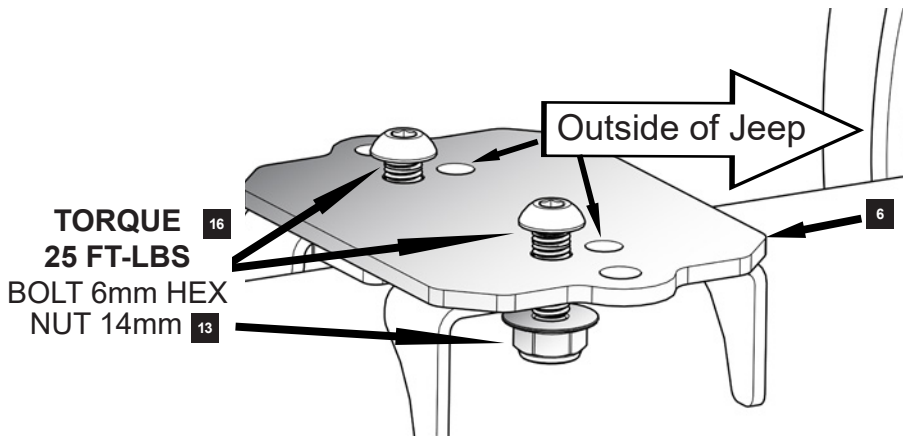

**TORQUE 25 FT-LBS**

**BOLT 6mm HEX  
NUT 14mm**

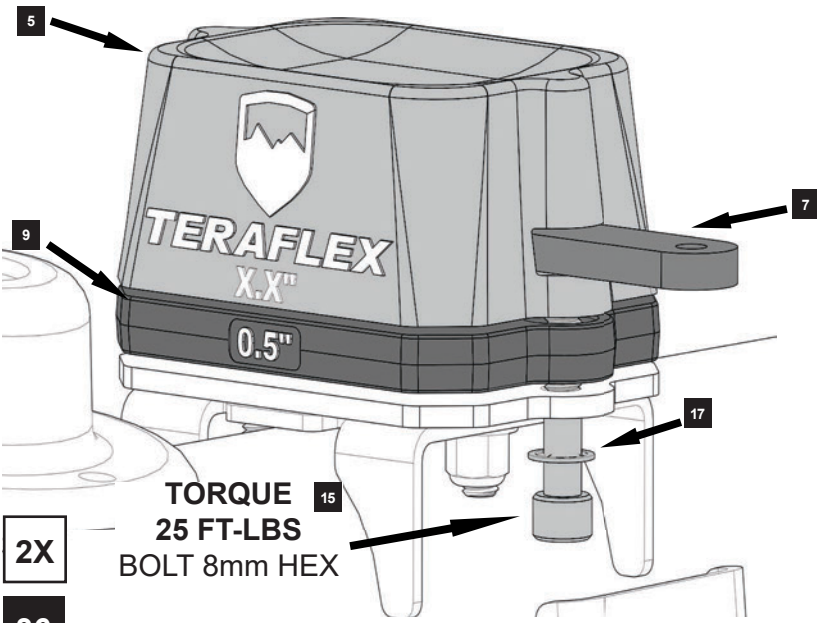

**TORQUE 25 FT-LBS  
BOLT 8mm HEX**

**2X**

**36**

**NOTE: REFER TO PAGE 17 FOR BUMPSTOP SPACER GUIDE**

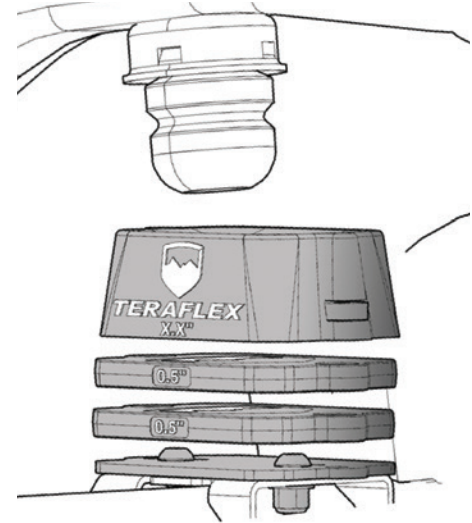

**REINSTALL BRAKE LINE BRACKETS**

**RECONNECT PLASTIC RETAINERS FROM WIRING OR HOSES AS NEEDED**

REINSTALL BOLT 13mm

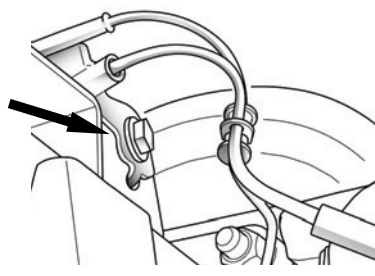

2X

**NOTE: DO NOT TIGHTEN THE CONTROL ARM BOLTS UNTIL THE JEEP IS ON THE GROUND**

37

**INSTALL NEW SWAY BAR LINKS**

**TORQUE 45 FT-LBS**  
NUT 19 mm  
BOLT 8mm  
HEX KEY

2X

38

**TORQUE 66 FT-LBS**  
NUT 19mm  
STUD 6mm  
HEX KEY

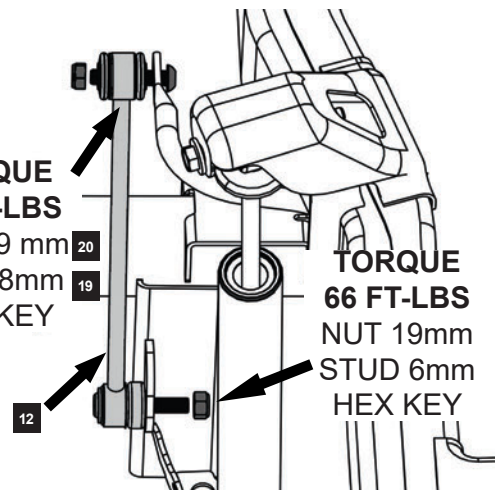

**REINSTALL TIRES AND LOWER TO THE GROUND**

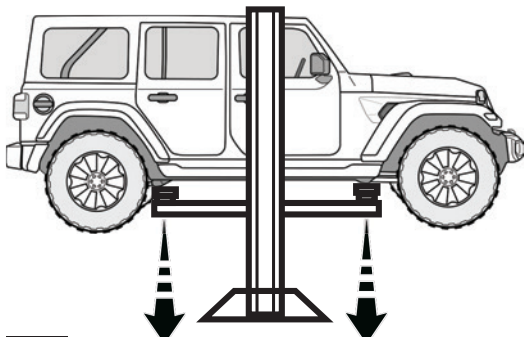

39

**TORQUE TO FACTORY SPEC**

**REINSTALL TRACK BARS AND TORQUE TO THE FOLLOWING SPECS**

**TORQUE REAR**  
BOLT 21mm  
74 Ft Lbs + 60°

40

**TORQUE FRONT**  
BOLT 18mm  
52 Ft Lbs + 155°

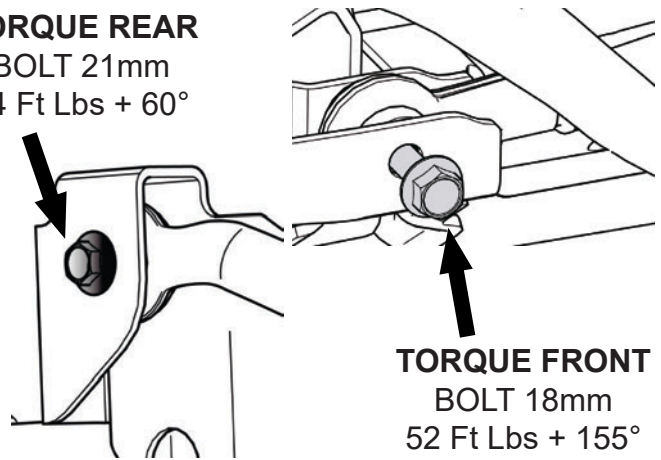

**TORQUE CONTROL ARMS**

REAR

**TORQUE 18mm**  
74Ft Lbs + 65°

**TORQUE 18mm**  
74Ft Lbs + 80°

2X

41

**TORQUE 18mm**  
74Ft Lbs + 50°

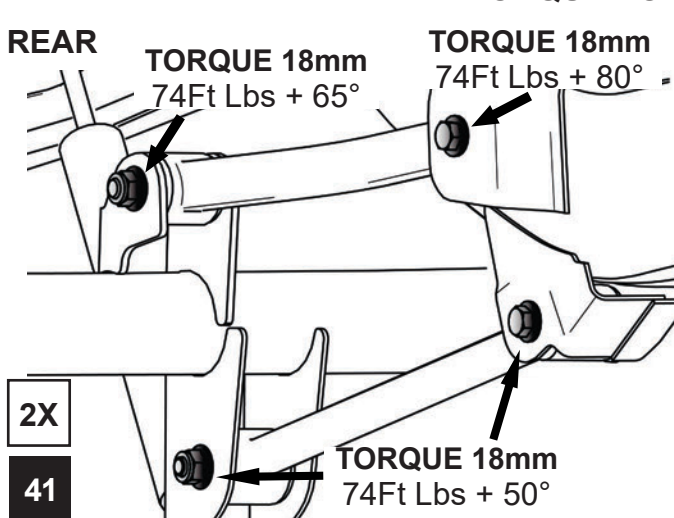

**TORQUE 18mm**  
37 Ft Lbs +135°

FRONT

**TORQUE 18mm**  
41Ft Lbs + 185°

**TORQUE 103 Ft Lbs +145°**  
BOLT 21mm  
NUT 24mm

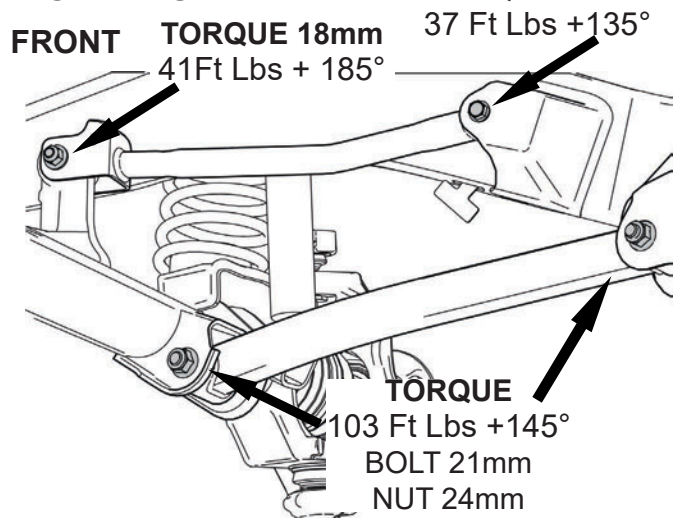



# JL Tire Clearance Guide (FACTORY FENDERS)

By limiting suspension up travel, TeraFlex Bump Stops allow the use of larger tires while keeping the factory fenders.

JL Rubicon models feature high-clearance fenders that allow for more up travel, while the lower-clearance fenders on JL Sport and Sahara restricts tire size due to fender rubbing.

In order to address these fender differences, TeraFlex designed a proprietary modular bump stop system, which can be adapted to fit several different lift height and tire size configurations.

In addition to the main 2" bump stop spacers, this system includes multiple 0.5" interlocking spacers that can be added to fine tune bump stop height to limit suspension up travel.

JL RUBICON

## JL Rubicon with Factory Fenders:

*See Notes: Not all Tires Measure the Same*

- 33" - No Bump Stops
- 35" - 2" Front & 2" Rear Bump Stops



- 37" - 2.5" Front & 3" Rear Bump Stops

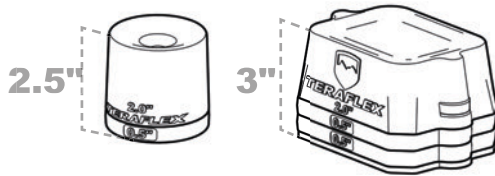

JL SPORT/SAHARA

## JL Sport/Sahara with Factory Fenders:

*See Notes: Not all Tires Measure the Same*

- 33" - No Bump Stops
- 35" - 3" Front & 2.5" Rear Bump Stops

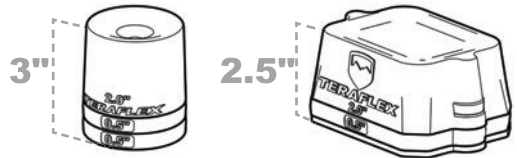

- 37" - 3.5" Front & 4" Rear Bump Stops

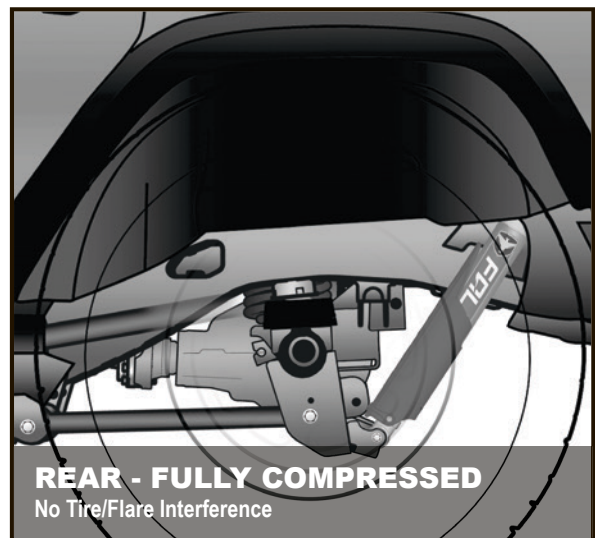
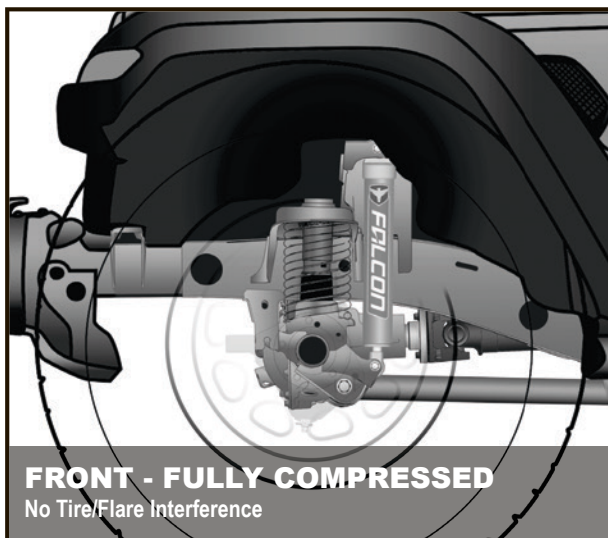
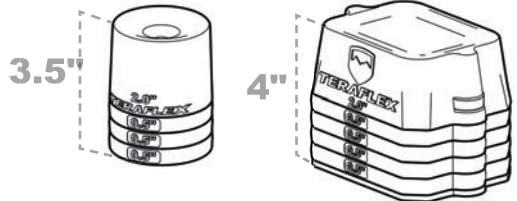

## 2-4 Inch Shock Options

### JL Falcon Adjustable PiggyBack Shocks

- 4 Door Series 3.3, 11-01-33-400-200-3
- 2 Door Series 3.3, 10-01-33-400-200-3

- \*Fast Adjust Knob
- \*High Flow Oil Channel
- \*Offset Sleeve Design
- \*PiggyBack Reservoir

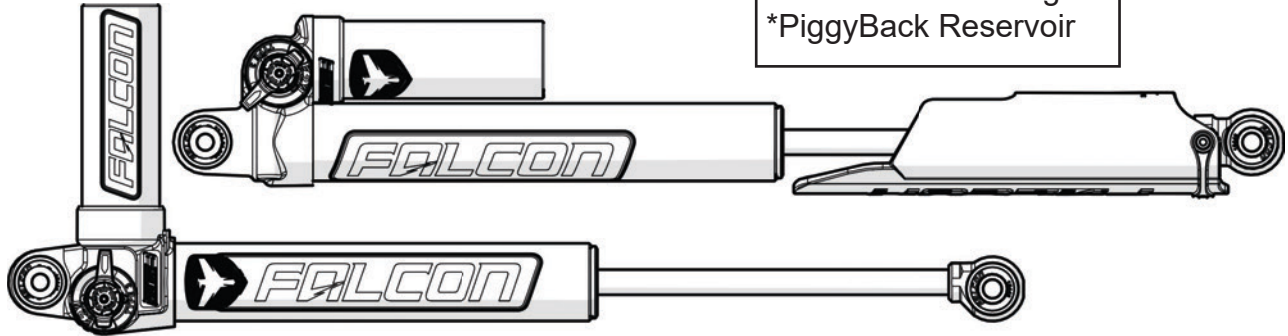

### JL Falcon PiggyBack Shocks

- 4 Door Series 3.1, 11-01-31-400-200-3
- 2 Door Series 3.1, 10-01-31-400-200-3

- \*Series 3.3 Upgradable
- \*High Flow Oil Channel
- \*Offset Sleeve Design
- \*PiggyBack Reservoir

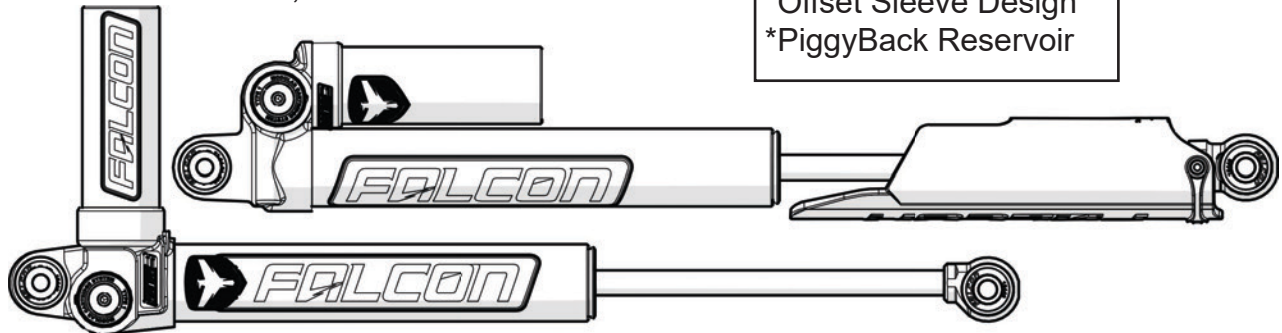

### JL Falcon Monotube Shocks

- 4 Door Series 2.1, 11-01-21-400-200-3
- 2 Door Series 2.1, 10-01-21-400-200-3

- \*Oil Gas Separator
- \*3/4" Chrome Shaft
- \*Offset Sleeve Design
- \*JL Specific Shock

