

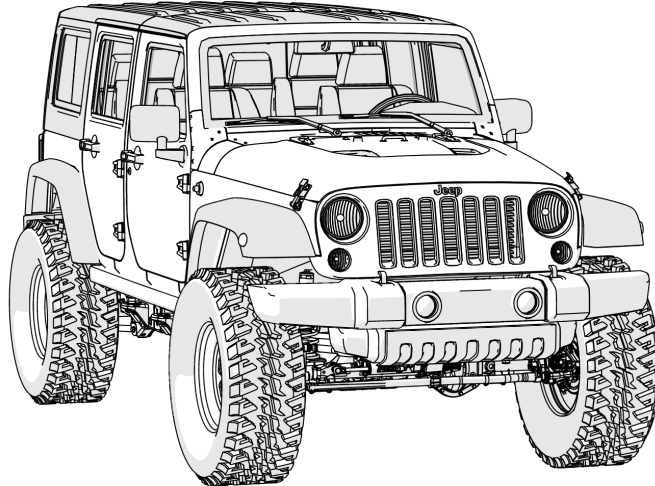

07-17 JK 4"-6" Suspension Lift Kit

Instructions



Important Notes:







Prior to beginning this or any installation read these instructions to familiarize yourself with the required steps and evaluate if you are experienced and capable to personally perform these modifications. A factory service manual should be used in conjunction with these installation instructions.





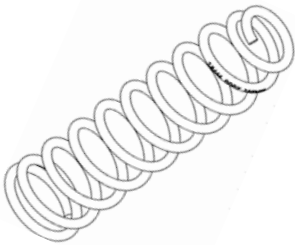
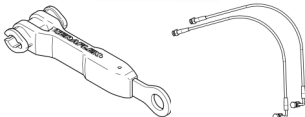
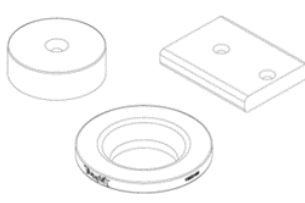
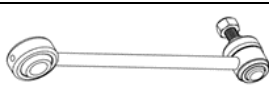
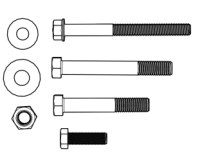

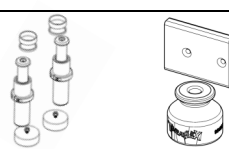
Refer to the parts list to ensure that all necessary components and hardware has been included. If any parts are missing please contact your local TeraFlex dealer for assistance.

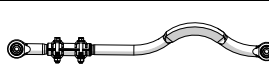
These instructions are for the 4"-6" Suspension Systems sold by Teraflex. Each system has steps that will be different from another system and *it is vital to read through each step completely* to understand when there are notes that belong to the Suspension System you are installing. Examples: For the Alpine CT6, Alpine CT4, and Prerunner Systems the axles will need to be completely removed and the control arm brackets are cut off the frame. For the 4" Plus Flexarms and Trackbars System the control arms and trackbars will be replaced. For the 4" Base System the control arms and trackbars will NOT be replaced.

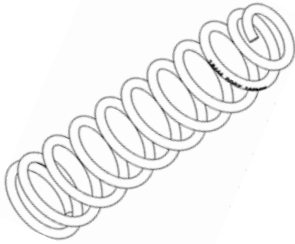
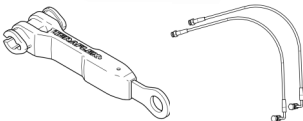
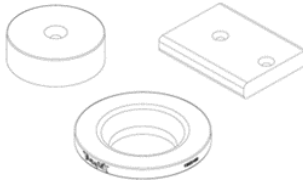
Tools Needed

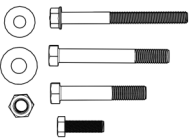
- Jack
- Car Lift (or Jack Stands)
- MIG Welder
- Ratchet - 1/4" and 1/2"
- 1/4" Drive Socket Set - 1/4", 5/16", 10mm, 7/16"
- 1/2" Drive Swivel/Wobbly Sockets - 18mm, 21mm, 3/4"
- 1/2" Drive Socket Set - 18mm, 21mm, 3/4"
- 1/2" Extension - 12" Long
- Allen Wrench - 3/16", 5mm
- End Wrench Set - 7/16", 1/2", 9/16", 1-1/8", 13mm, 15mm, 16mm, 18mm, 19mm, 21mm
- Drill
- Drill Bits - 1/8", 1/4", 3/8", 1/2" - or step drill bit
- Reciprocating Saw and Bi-metal Blade
- Wire Cutters
- Locking Pliers
- Heel Pry Bar
- Hammer
- Chisel
- Measuring Tape
- Blue Loctite
- FT - LBS Torque Wrench
- Safety Glasses
- Recommended: Transmission Jack, Air Gun, Plasma Cutter, Car Lift

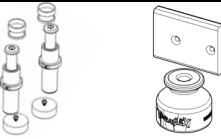
									
				4DR	2DR	4DR	2DR	4DR	2DR
Spring Box Components		Front	1853600	2					
		Rear	1854600	2					
		Front	1853400		2	2		2	
		Rear	1854400		2	2		2	
		Front	1853200				2		2
		Rear	1854200				2		2
		5" Brake Line Anchor Kit	1101255			1	1	1	1
		10" Brake Line Anchor Kit	1101355	1	1				
		30" Brake Line, Pair	4350300	2	2	2	2	2	2
		Front Spring Spacer	1953100	2	2	2	2	2	2
		Rear Spring Spacer	1954105	2	2	2	2	2	2
		Exhaust Spacer	2610000	1	1	1	1	1	1
		Rear Lower Bumpstop Spacer	954600	6	6	6	6	6	6
		Front Bumpstop Pad	467125	2	2	2	2	2	2
		Swaybar Link, Front Quick Disconnect	753020	2	2	2	2	2	2
		Rear Swaybar Link	754420	2	2	2	2	2	2
		Rear Trackbar Bracket Hardware	600080	1	1	1	1	1	1
		QD Hardware	600093	1	1	1	1	1	1
		4" Lift Kit Hardware	602175	1	1	1	1	1	1
		Cam Bolt Eliminating Kit	4951700	1	1	1	1	1	1
	Front Trackbar Bracket Plate	4951800	1	1	1	1	1	1	
	Rear Axle Trackbar Bracket	954777	1	1	1	1	1	1	
Other Boxed Kits		SpeedBump Kit +Bumpstops	1958250	1	1	1	1		
		Prerunner SpeedBump Kit	1958259					1	1
		Bumpstop Extension Kit	1954625						
		Long Adjustable FlexArm Bracket Kit	1957000	1	1	1	1	1	1
		Alpine Lower Long Arm Kit	1315001	1	1	1	1	1	1
		Alpine Upper Long Arm Kit	1315002	1	1	1	1	1	1
		Alpine Adjustable Control Arm Kit	1415610						
		Front Monster Trackbar Kit	1753418	1	1	1	1	1	1
		Rear Monster Trackbar Kit	1754418	1	1	1	1	1	1
	Other Kits	Limit Strap Kit	4853100					1	1
Premium HD Drag Link Flip Kit		1600450	1	1					

				4" W/ 8 Alpine Flex-arms & Trackbar		4" Base		
				4DR	2DR	4DR	2DR	
Spring Box Components	Description		Item #					
		Front	1853600					
		Rear	1854600					
		Front	1853400	2		2		
		Rear	1854400	2		2		
		Front	1853200		2		2	
		Rear	1854200		2		2	
		5" Brake Line Anchor Kit	1101255	1	1	1	1	
		10" Brake Line Anchor Kit	1101355					
		30" Brake Line, Pair	4350300	2	2	2	2	
		Front Spring Spacer	1953100	2	2	2	2	
		Rear Spring Spacer	1954105	2	2	2	2	
		Exhaust Spacer	2610000	1	1	1	1	
		Rear Lower Bumpstop Spacer	954600	6	6	6	6	
		Front Bumpstop Pad	467125	2	2	2	2	
		Swaybar Link, Front Quick Disconnect	753020	2	2	2	2	
		Rear Swaybar Link	754420	2	2	2	2	
		Rear Trackbar Bracket Hardware	600080	1	1	1	1	
		QD Hardware	600093	1	1	1	1	
		4" Lift Kit Hardware	602175	1	1	1	1	
		Cam Bolt Eliminating Kit	4951700	1	1	1	1	
		Front Trackbar Bracket Plate	4951800	1	1	1	1	
		Rear Axle Trackbar Bracket	954777	1	1	1	1	
Other Boxed Kits		SpeedBump Kit +Bumpstops	1958250					
		Prerunner SpeedBump Kit	1958259					
		Bumpstop Extension Kit	1954625	1	1	1	1	
		Long Adjustable FlexArm Bracket Kit	1957000					
		Alpine Lower Long Arm Kit	1315001					
		Alpine Upper Long Arm Kit	1315002					
		Alpine Adjustable Control Arm Kit	1415610	1	1			
		Front Monster Trackbar Kit	1753418	1	1			
		Rear Monster Trackbar Kit	1754418					
	Other Kits	Limit Strap Kit	4853100					
		Premium HD Drag Link Flip Kit	1600450					

LIFT THE VEHICLE

Lift the vehicle and support it by the frame and remove wheels.

4" +FLEXARMS AND 4" BASE KITS: Skip to step 3

1

FRONT AND REAR BRAKE CALIPERS

CT6, CT4, AND PRERUNNER KITS: Remove the front and rear calipers with the anchor brackets with a 21mm. Support the caliper from the frame, do not allow the caliper to hang from the brake hose. A plastic zip tie works well.

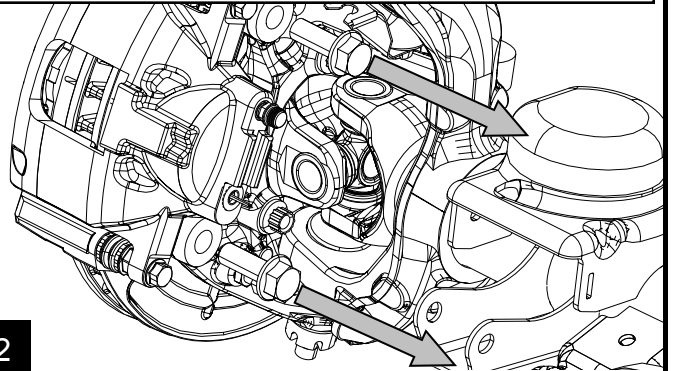

2

REMOVE EXHAUST AND T-CASE SKID PLATES

Remove the transfer case skid plate and exhaust skid plate/cross member using an 18mm (the exhaust skid plate will not be reused).



3

DRIVELINES

4" +FLEXARMS AND 4" BASE KITS: With a 5/16" remove the front and rear drivelines at the axle and secure out of the way with a bungee cord.

CT6, CT4, AND PRERUNNER KITS: Completely remove the front and rear driveline. The front will be removed with a 5/16" on the 8 CV bolts and for complete removal a 15mm on the u-joint flange bolts. For the rear driveline use the same 5/16".



4

TIP: Through the two access holes in the rear flange, use a punch to free the driveline from the axle. Do not let the axle hang from the CV joint. The transfer case end will be easier to remove.

FRONT AND REAR SWAY BAR LINKS

Remove the sway bar links, using an 18mm socket and wrench, at the axle, and an 18mm socket and 19mm wrench, at the sway bar.

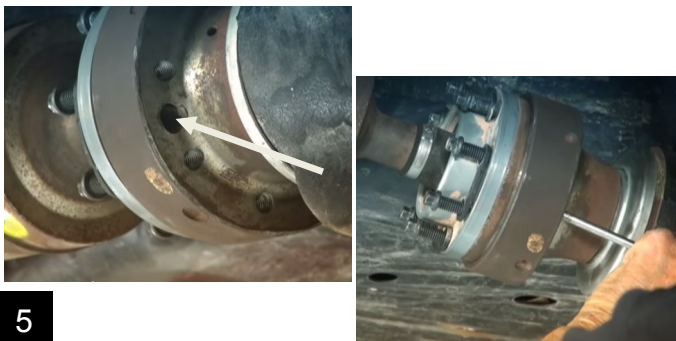

5

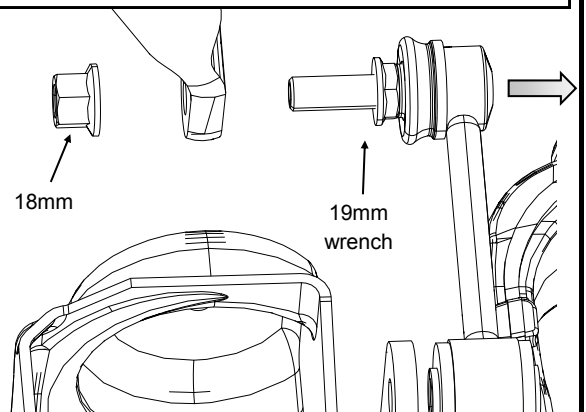

6

DISCONNECT DRAG LINK FROM AXLE

Loosen 21mm Drag Link nut at the knuckle, do not completely remove nut. Hit the knuckle with a hammer, where the drag link rod end goes through it, to release drag link from the knuckle. Remove nut and tie drag link up out of the way.

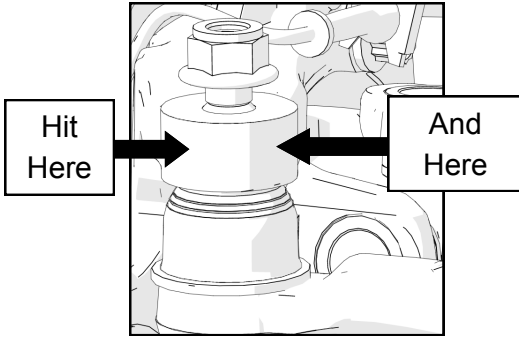

7

TRACK BARS

4" BASE KIT: Remove the Front and Rear Trackbars at the axle side only using a 21mm.

4" +FLEXARMS KIT: Remove the Rear Trackbar at the axle side only and completely remove the Front Track Bar.

CT6, CT4, AND PRERUNNER KITS: Completely remove the Front and Rear Track Bars.

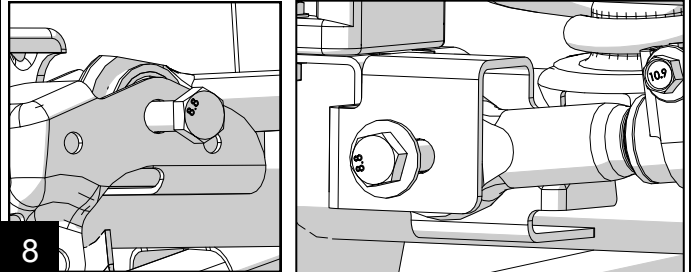

8

PARKING BRAKE CABLE AND BRACKET

4" +FLEXARMS AND 4" BASE KITS: Remove the parking brake bracket, with a 10mm deep socket, and discard the bracket.

CT6, CT4, AND PRERUNNER KITS: Remove the parking brake bracket, with a 10mm deep socket, and discard the bracket. Remove the parking brake cable from the axle

Remove and discard



4" +FLEXARMS AND 4" BASE KITS: Skip to step 12.

CT6, CT4, AND PRERUNNER KITS: Remove wheel speed sensors. Use a 10mm to remove the rear sensor. For the front sensor, loosening the (3) 13 mm 12 point bolts in wheel hub bearings so the brake dust plate can move out of the way and the sensors can be removed.

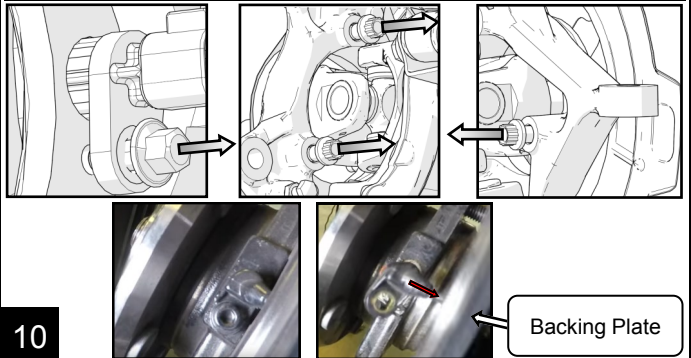

CT6, CT4, AND PRERUNNER KITS: Remove the breather hoses and harness fasteners from the axles. Also remove Locker Actuators and Sensor Harnesses if your vehicle is equipped with them.



FRONT SHOCKS

Support the front axle and remove the shocks with an 18mm on the bottom and a 17mm top. **NOTE:** On 2012+ JK's, the passenger side upper shock mount is not accessible due to the battery tray. Use a pair of pliers and break out enough of the thin plastic to gain access to the 17mm nut.

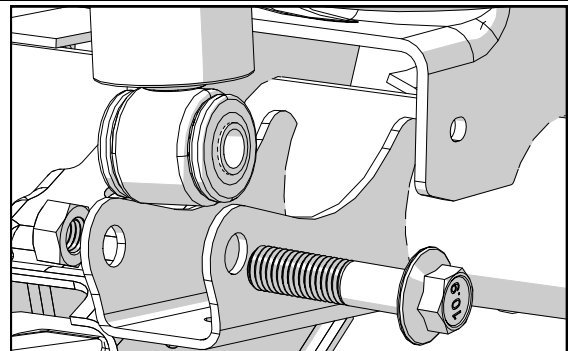

FRONT CONTROL ARMS

4" BASE KIT: With a 21mm and an 18mm loosen the control arm bolts.

4" +FLEXARM KIT: With a 21mm and an 18mm remove and replace the bottom control arms first then the top.

CT6, CT4, AND PRERUNNER KITS: Remove all four front control arms with a 21mm and an 18mm. Keep the hardware.

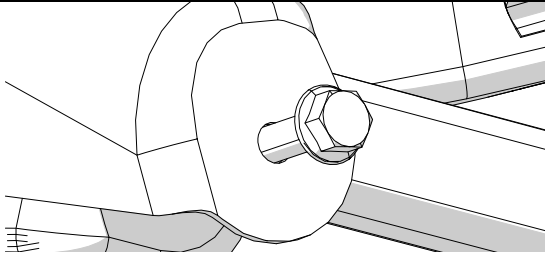

13

FRONT SPRINGS

4" +FLEXARMS AND 4" BASE KITS: Lower the axle and remove the front springs. Check for any lines that might get damaged that were missed earlier.

CT6, CT4, AND PRERUNNER KITS: Lower the axle and remove the front springs. Remove the front axle and set in a safe place.

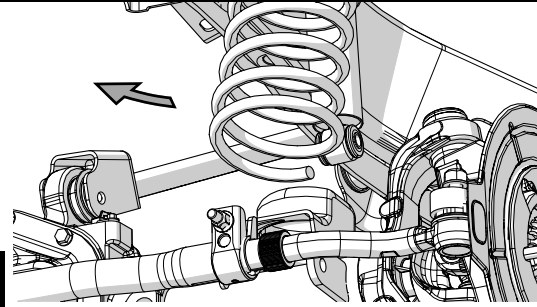

14

REAR SHOCKS

Support the rear axle. Apply penetrating oil to rear shocks upper bolts. *These are captured nuts and a broken bolt here is a real inconvenience.*

Remove the two upper bolts with a 16mm. Remove the lower nut and bolt with an 18mm.

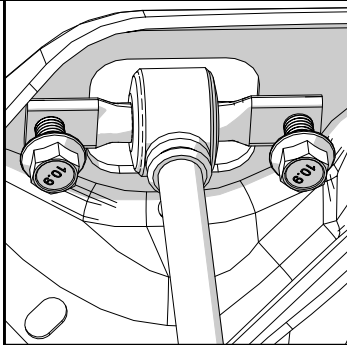

15

REAR CONTROL ARMS

4" BASE KIT: With a 21mm loosen the rear control arm bolts.

4" +FLEXARM KIT: With a 21mm remove and replace the bottom control arms first then the top.

CT6, CT4, AND PRERUNNER KITS: Remove all four rear control arms with a 21mm. Keep the hardware.

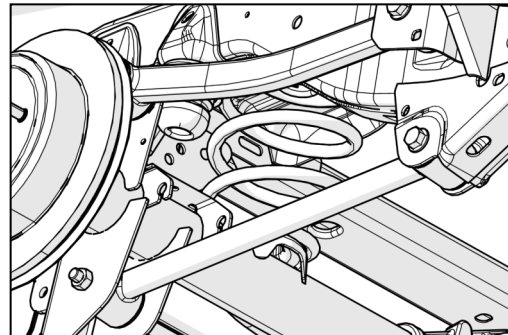

16

REAR SPRINGS

4" +FLEXARMS AND 4" BASE KITS: Lower the rear axle and remove the springs. Check for any lines that might get damaged that were missed earlier.

CT6, CT4, AND PRERUNNER KITS: Lower the rear axle and remove the springs. Remove the rear axle and set in a safe place.

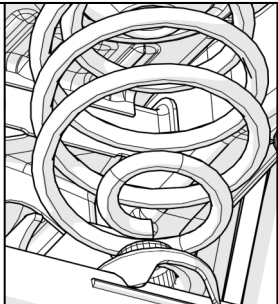

17

4" +FLEXARMS AND 4" BASE KITS: Skip to step 38.

REMOVE THE GAS TANK

CT6, CT4, AND PRERUNNER KITS: Remove Gas Tank starting with the filler neck (use a 6mm socket on the hose clamp). Use a screwdriver, or equivalent, to depress the white release clip on the vent line and disconnect.



18



Disconnect the supply and return lines by squeezing the blue tabs. **Caution!** The supply line may still be under pressure. Have a rag ready to absorb any fuel leaks.



19

Be sure to cap/protect any open fuel lines. On most models the supply and return lines can be snapped together.



20

Disconnect the EVAP lines that run between the EVAP system and the fuel tank.



21

Remove the 8 bolts supporting the tank and slowly lower it. Beware of fuel/electrical lines that are still connected. Once you have access, remove the remaining electrical connections.



22

T-CASE CROSS MEMBER

Support transfer case and remove nuts and bolts from the cross member. Leave one bolt in and swing cross member out of the way.



23

EXHAUST

Remove exhaust starting with four 14mm flange bolts. Spray exhaust hangers with some silicon spray or penetrating oil. Use a pry bar to pry rubber hangers off and remove exhaust.

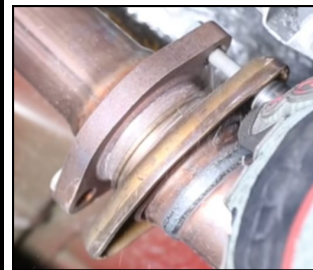

24

REINSTALL T-CASE CROSS MEMBER

With this portion of exhaust out of the way reinstall the transfer case cross member with all 4 bolts pointing forward (do not tighten bolts). The transfer case support stand can now be removed.

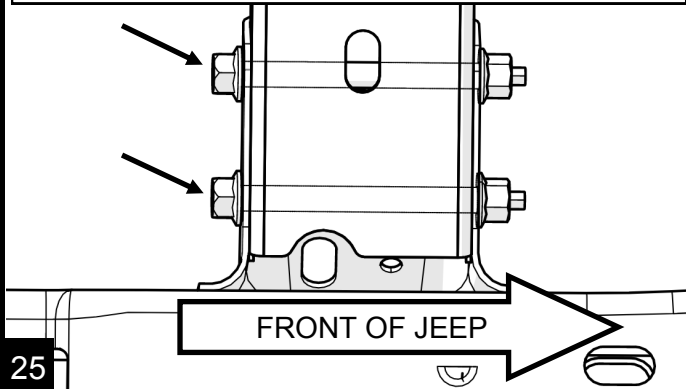

25

REMOVE CATALYTIC CONVERTERS

Disconnect all four O2 sensor connects, one black and one white on each side. Remove both catalytic converters from the manifolds by removing the bolts, with a 10mm, at the top of the flange.



26

CUT OFF CONTROL ARM BRACKETS

Un-clip all wire loom and fuel lines near where you will be cutting and welding. Tuck them above the frame or where they will not be damaged. With all control arms removed, begin cutting and removing the control arm brackets. Take extra care not to cut into the frame. Pay special attention to the direction of your flames and sparks as well as any hoses or wires that could be effected by the heat. Beware of any brake lines above the upper control arm mount on the drivers side as well.

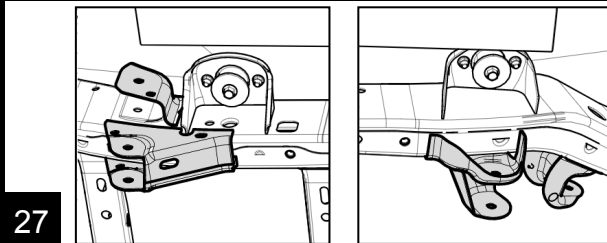

27

CHASIS AND BRACKET PREP

After cutting is complete, grind down all remaining slag and metal to make a smooth surface for mounting the new brackets to. We suggest using a flapper wheel on a 4" angle grinder. **NOTE:** Avoid long, vertical welds on the frame; this may lead to cracking and frame failure.

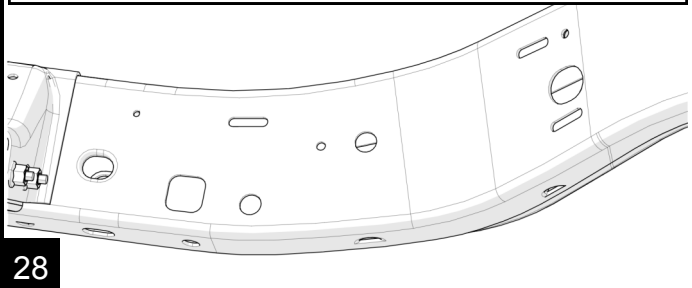

28

The front brackets index to a hole in the bottom of the frame and two bolts in the cross-member. Replace the cross-member bolts with longer, provided bolts. Mark the locations to be welded on the frame and remove the bracket. Clean off any paint within 1" of where welding will occur. Also, the new control arm brackets will need to have the powder coat cleaned off from the welding surfaces. A clean surface is key to a strong, lasting weld.

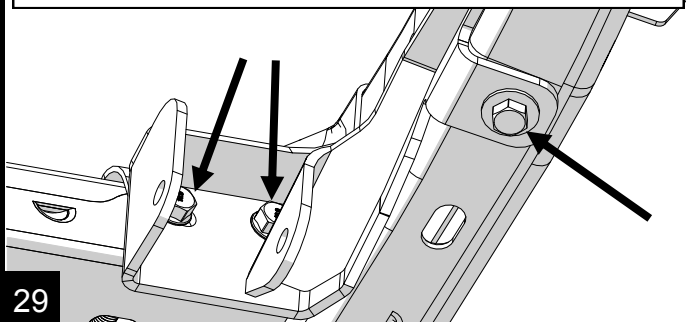

29

Reinstall the front bracket and weld it onto the frame. **NOTE:** Use C-clamps to eliminate any gaps between the new brackets and the frame. Do several tack welds around the bracket to keep it from warping as you weld. By minimizing the bracket gap you will get a much better weld.

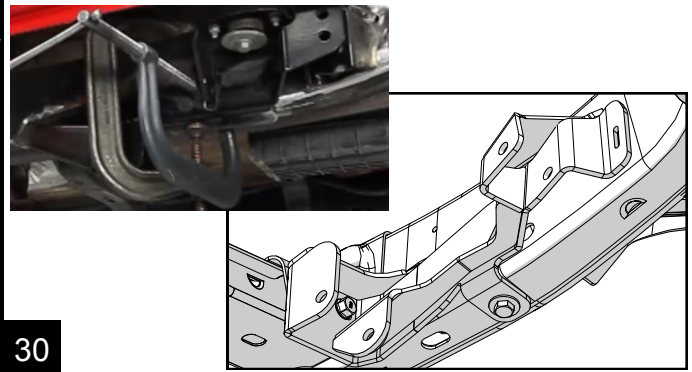

30

The rear gusset plate locates to a control arm hole in the frame. This will be welded in place before the rear bracket.

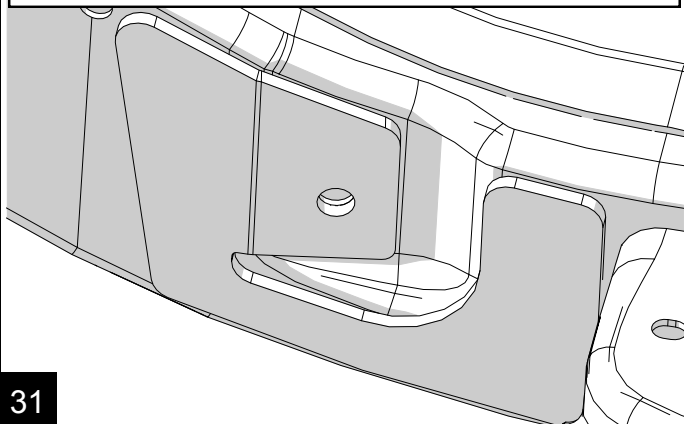

31

Clean off any paint within 1" of where welding will occur. Use C-clamps where needed and weld on the rear frame gussets.

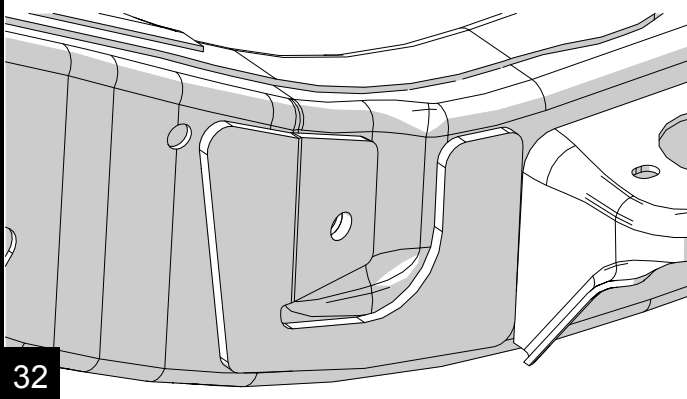

32

The rear brackets index around a body mount bracket. Center the slot in the bracket around the body mount. Mark the frame where the brackets are to be welded to the frame.

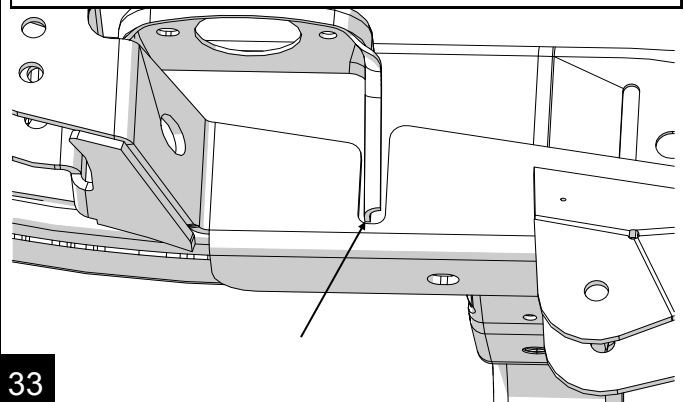

33

Clean off any paint within 1" of where welding will occur. Use C-clamps where needed and weld on the rear brackets. After welding on all the brackets take some time to clean the welded surfaces and any slag that is on the frame and brackets. Primer and paint exposed metal surfaces to prevent rust.

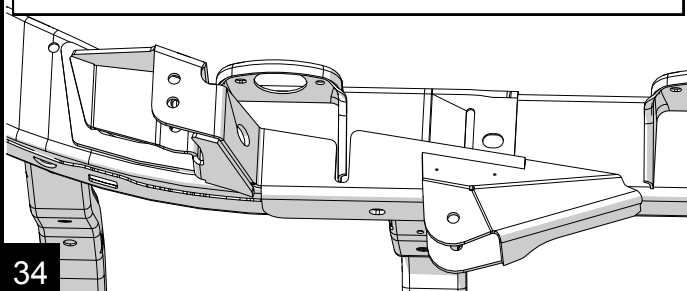

34

REINSTALL THE FUEL TANK

Reinstall the fuel tank in the reverse order removed. Don't forget any fuel lines, EVAP lines or electrical connections. Torque strap bolts to 30 ft-lbs.



35

REINSTALL CATALYTIC CONVERTERS

Reinstall both catalytic converters from the manifolds. Reconnect all four O2 sensors (one black and one white on each side).



36

REINSTALL EXHAUST

Loosen Y-pipe exhaust clamp bolt and remove indexing nub from Y-pipe. Separate Y-pipe from the rear section of the exhaust.



37

2012 AND NEWER JKS: If you are installing this lift on a 2012 and newer Wrangler, you must install the provided exhaust spacer kit. See step 39.

2011 AND OLDER JKS: Push rear of Y-pipe over the top of the transfer case cross member first and snugly install both front flanges. Skip to step 40.

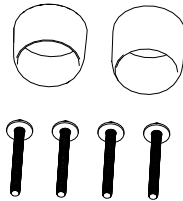

38

2012 AND NEWER JKS: Reinstall Y-pipe exhaust with supplied exhaust spacers. Push rear of Y-pipe over the top of the transfer case cross member first. Insert the spacers between the flanges. (The longer spacer is used on the passenger side.) Install new longer bolts into the flanges and snug down evenly. Make sure the exhaust pipes are still properly aligned and the spacers are straight.



39

Reinstall rear section of the exhaust back onto Y-pipe and onto the hangers. Check the exhaust system for straightness and clearance and tighten the exhaust clamp and flange bolts.

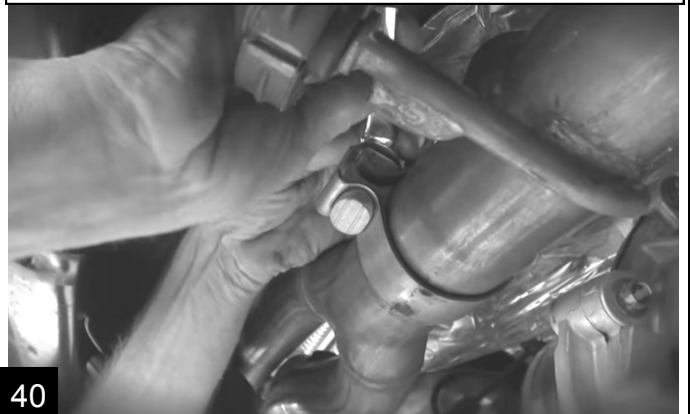

40

REAR UPPER BUMPSTOPS

4" +FLEXARMS AND 4" BASE KITS: Refer to Instruction #999301

PRERUNNER KIT: Refer to Instruction #999299

CT6 AND CT4 KITS: Refer to Instruction #999292

41

4" BASE AND 4" +FLEXARMS KITS: Skip to step 45

INSTALL ALPINE LONG FLEXARM

CT6, CT4, AND PRERUNNER KITS: Adjust the length of your new Alpine Flexarms to:

- Front Uppers: 27 3/4"
- Front Lower: 33 11/16"
- Rear Uppers: 19 1/2"
- Rear Lower: 35 1/8"

Install the new long arms with the adjustable end at the axles. The new hardware will be used at the frame in the new control arm brackets and the original hardware will be used at the axles. Do not tighten the control bolts until the Jeep is on the ground. This is important for bushing life, flex, and ride quality.

42

Position rear axle under Jeep. For most applications the rear upper arms will be mounted in the lower holes in the new control arm brackets. Use the provided 9/16" x 3.5" bolts and washers at the frame and the original hardware will be used at the axles.

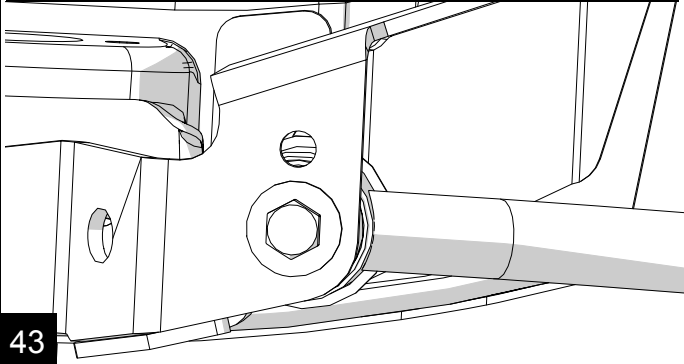

43

The rear lower arms are mounted with the bends in and up for maximum clearance. Use the 9/16" x 4.5" bolt and washers at the frame and the original hardware will be used at the axles.

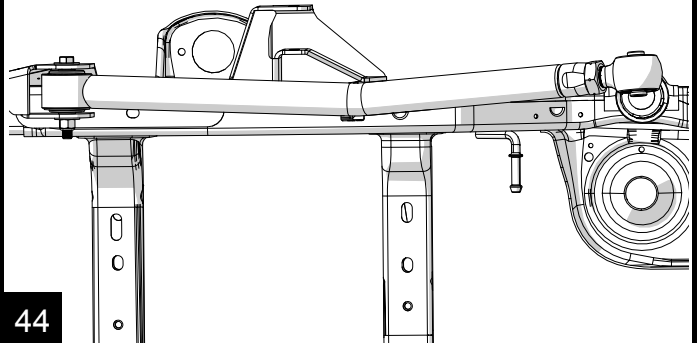

44

REAR TRACKBAR BRACKET

Locate the trackbar bracket and hardware kit. The lower ear of the trackbar bracket, and the driver lower control arm share the same bolt. They will need to be installed together.

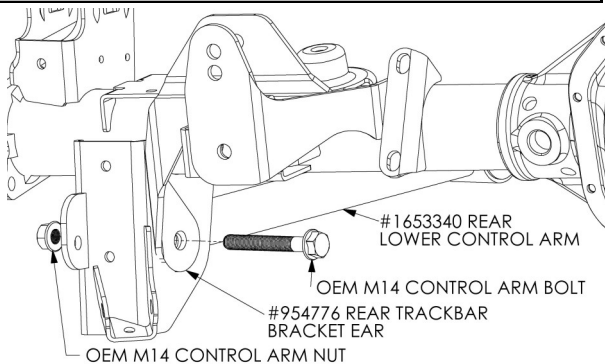

45

Position the trackbar bracket for install and swing the lower control arms up into place and insert the lower control arm bolt. Do not tighten. Install the trackbar bracket sleeve spacer and #242 bolt, #37 washer and #214 nut.

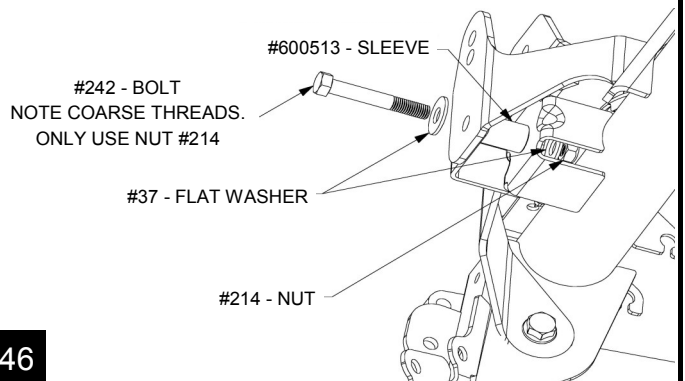

46

Install the U-bolt nuts and washers.
Torque the U-bolt lock nuts to 45 ft-lbs
Torque: 1/2" bracket bolt with the spacer to 75 ft-lbs
Do not torque the control arm bolt.

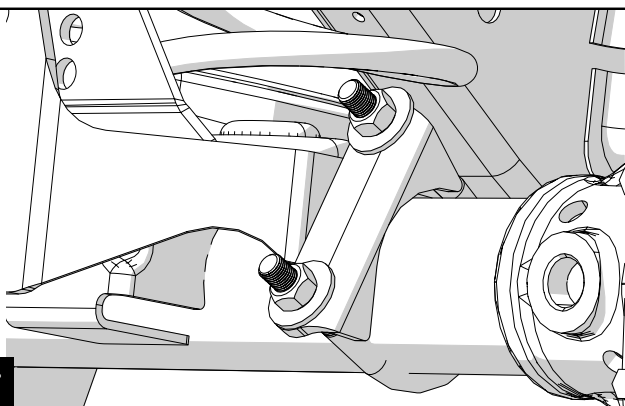

47

CT6, CT4, AND PRERUNNER KITS: Install new Rear Monster Track Bar in the upper hole of the new bracket and with the factory hardware.

4" +FLEXARMS AND 4" BASE KITS: Reinstall trackbar using the upper hole in bracket and the factory hardware.

Do not tighten track bar bolts. NOTE: If getting the bolt holes to line up is difficult wait until Jeep is on the ground, then have a helper push the Jeep from the side to line up holes.

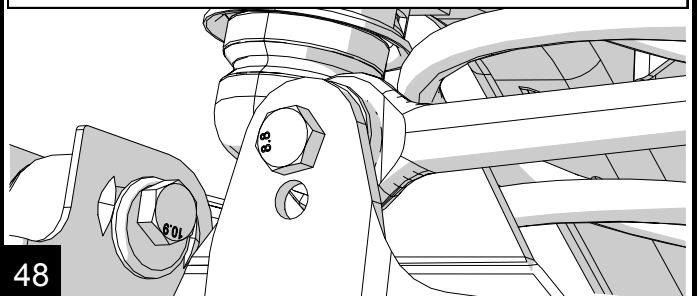

48

SPRING SPACERS

Remove the factory isolator from the upper spring perch and install onto the new spring spacer. To aid in installation, apply grease to the top of the new spacer. Press the isolator and spacer assembly into the upper spring perch. You can use a piece of wood as a spacer between spring spacer and the axle, then raise the axle to press the spacer in.

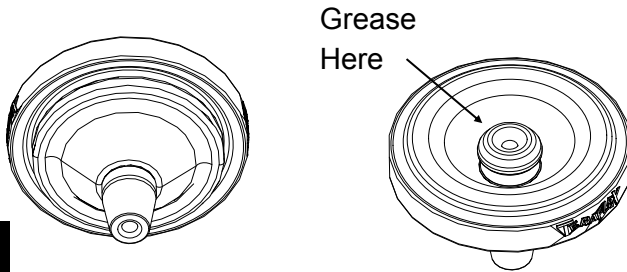

49

INSTALL REAR SPRINGS

Install the factory rear upper spring isolators and the new rear coil springs. **Note:** The upper pigtail end needs to be all the way to the rear of the Jeep.

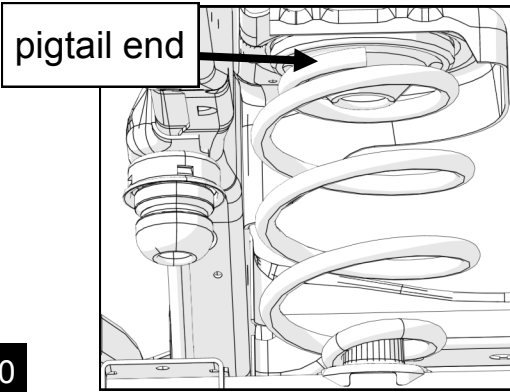

50

REAR SHOCKS

If your kit came with Falcon Shocks then install them now, following their instructions. If installing other shocks install them using the two upper bolts with a 16mm and the lower nut and bolt with an 18mm. Torque the upper bolts to 37 ft-lbs (50 Nm) and lower bolts to 56 ft-lbs (76 Nm).

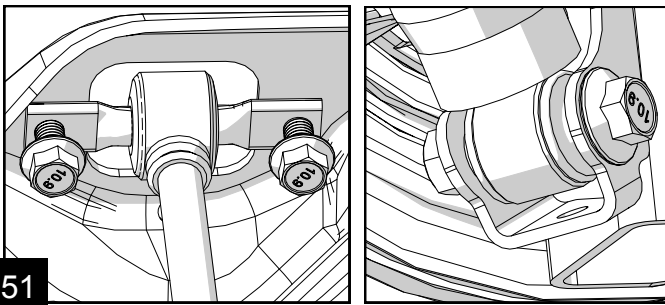

51

INSTALL REAR LOWER SPRING RETAINER

Place the retainer on the lower spring pad. Install the 3/8" bolt and lock washer through the spring retainer and spring pad. Place a nut into the provided tool. Slide the tool underneath the spring pad from the front of the axle and thread the bolt into the nut. **Torque the bolts to 30 ft-lbs (41 Nm)**

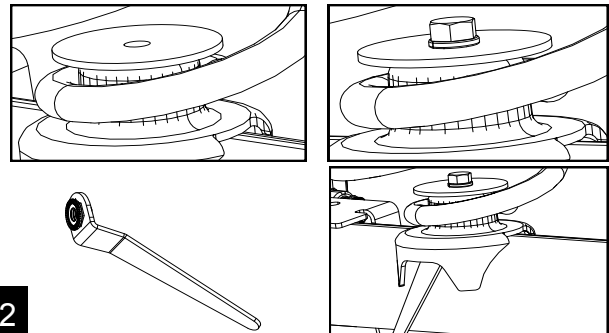

52

CT6, CT4 AND PRERUNNER KITS: Position rear axle under Jeep and install control arms.

INSTALL FRONT BUMP STOPS

NOTE: All 4" and 6" lift kits come with an additional set of Lower Speedbump Pads. These are intended to be installed stacked together with the set provided in your Bump Stop Kit. (Make sure to follow the noted steps outlined in the Bump Stop Instructions)

CT6 AND CT4 KITS: Refer to Instruction #999292

PRERUNNER KIT: Refer to Instruction #999299

4" +FLEXARMS, AND 4" BASE KITS: Refer to Instruction #999301

53

NOTE FOR INSTALLING FRONT SPRINGS

When install the front coil springs, do the drivers side first, followed by the passenger side. Rotate the spring until they are fully seated.

Follow the bump stop instructions for installing the front springs and shocks.

Remember to leave the lower bolts loose.

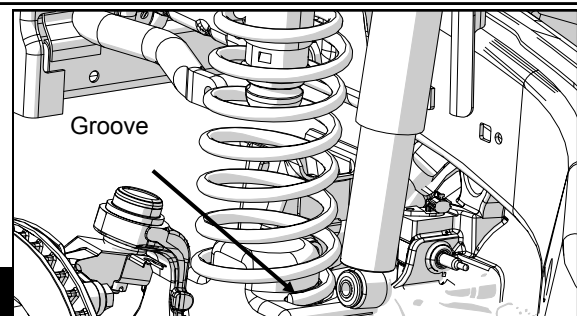

54

FRONT SHOCKS

If using Falcon Shocks follow instruction included with them to install the fronts now. If using other shocks install them now. Torque the top nut to 20 ft-lbs (27 N-m). Leave lower bolt loose for the brake line anchor install.

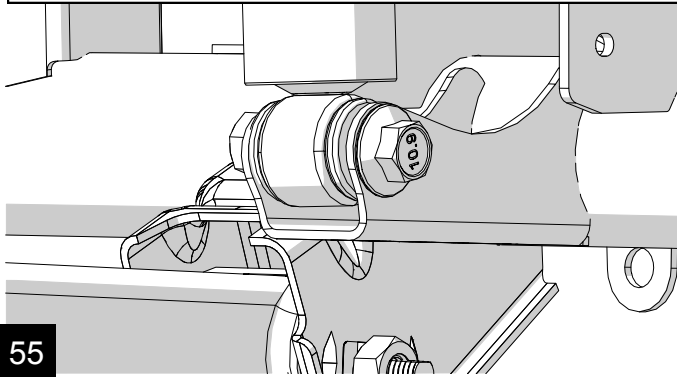

Reinstall drivelines and align the flange marks. At the transfer case; torque to 15 ft-lbs. Front axle flange; torque to 81 ft-lbs. Rear axle flange; torque to 15 ft-lbs.

Note: The rear drive line can be rotated, if desired, to get the boot out of harms way.

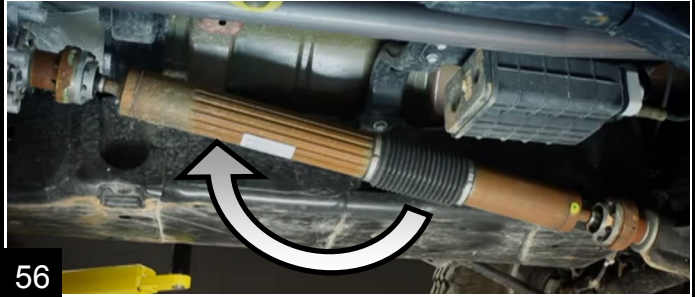

Reinstall Breathers and Harnesses back onto axles, as well as locker system cables if applicable. Secure the axle breather tube to the cross member.

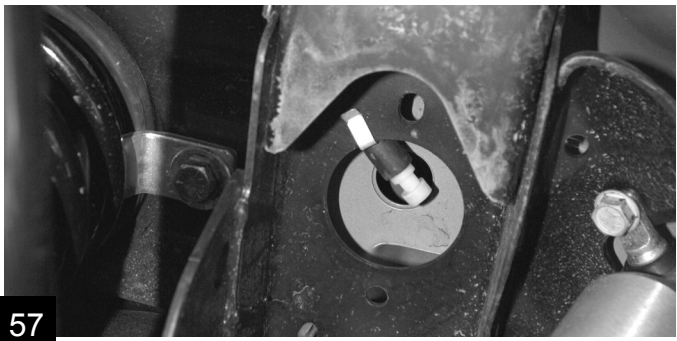

CT6 KIT: Refer to Instruction 999104# for installing the Frame Brace and Drag Link Flip Kit.

CT6, CT4 AND PRERUNNER KITS: Reinstall Park Brake Cable, Front and Rear Brake Calipers, Front and Rear Wheel Speed Sensors, and Drag Link to the Axle

FOR PRERUNNER KITS: Refer to the Limiting Strap Instruction #999050

58

Install new rear swaybar link with the swivel end on the swaybar (on the outside). Install the new lock nut using the 19mm end wrench and the 6mm allen wrench. **Torque to 66 ft-lbs.** Using an 18mm to install the factory hardware and two provided washers on the lower end of the link. Place a washer on both sides of the bushing. **Torque to 75 ft-lbs.**

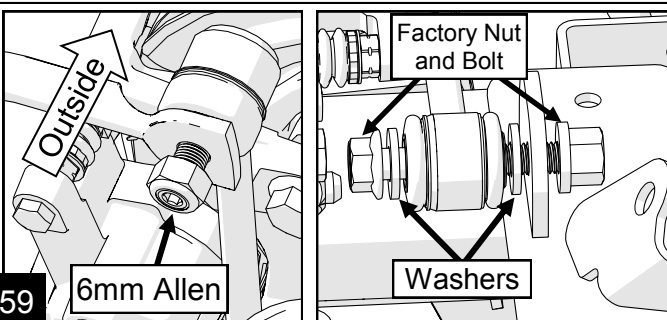

FRONT SWAYBAR QUICK DISCONNECT KIT

RUBICON OWNERS: If you decide not to install the Quick Disconnect Kit the new swaybar links will need to have the provided sleeve installed to work with your factory hardware. Insert 3/4" Quick Disconnect stud into lower link bracket on the axle (as shown). Install with a 1/2" washer and nylock nut. **NOTE:** The stud is stainless steel and the threads are soft. Take care to not over tighten the nut.

Torque nut to 75 ft-lbs.

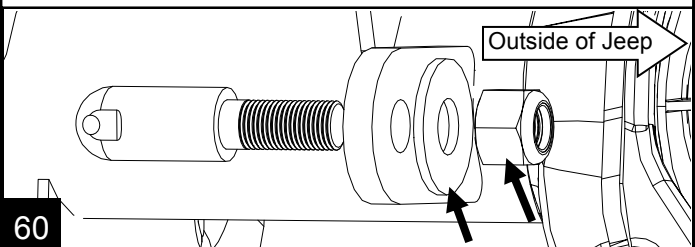

Install the swivel stud of the quick disconnect sway bar link into the sway bar. Place 7/16" washer and M12 nylock nut onto the stud. Use a 6mm allen to hold the stud, tighten down the nut with a 18mm wrench. **Torque nut to 75 ft-lbs.**

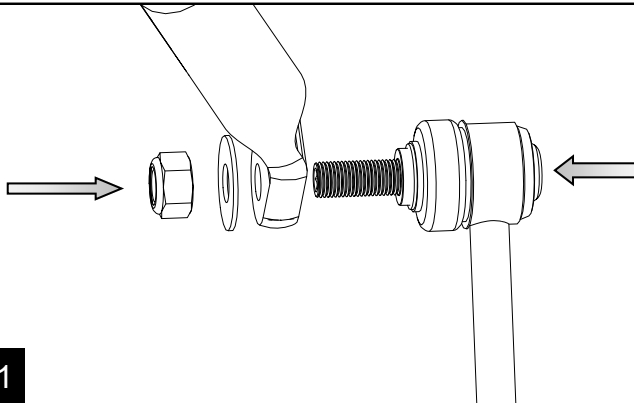

61

Push the lower end of swaybar links onto the lower stud installed on the axle. **TIP:** This should be a tight fit for better sway bar function. Applying a bit of grease onto the stud and bushing will help with installing. Secure the links with provided 3/4" x .124" thick washer and Bow Tie Pin (as shown).

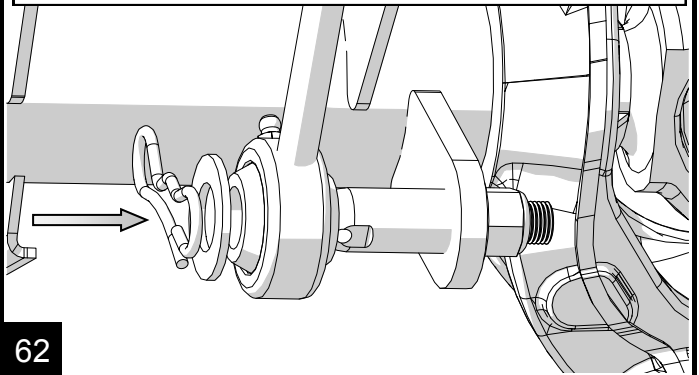

62

Remove the front body mount nut from the stud and slide on (600277) retaining bracket. Next insert 5/8" QD stud into retaining bracket and install 3/8" jam nut.

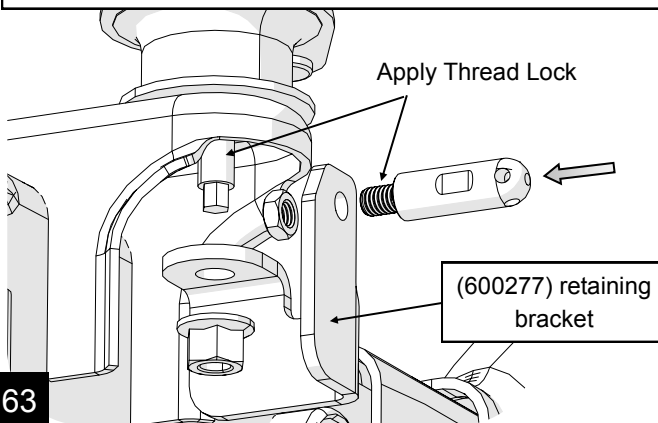

63

Torque the body mount to **80 ft-lb** and jam nut to **75 ft-lb.**

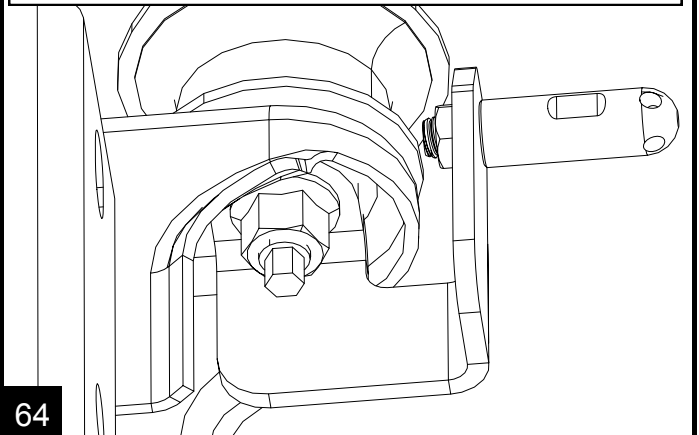

64

FRONT TRACK BAR INSTALL

CT6, CT4, PRERUNNER AND 4" +FLEXARMS KITS: Refer to Instruction #999044.

4" BASE KIT: Reinstall the track bar onto the axle. **Tip:** If the holes do not line up then install it once the Jeep is on the ground by having a helper move the steering wheel. This will move the Jeep relative to the axle and help the holes to line up. Do NOT tighten bolt. **Once the Jeep is on the ground, torque both bolts to 125 ft-lbs.**

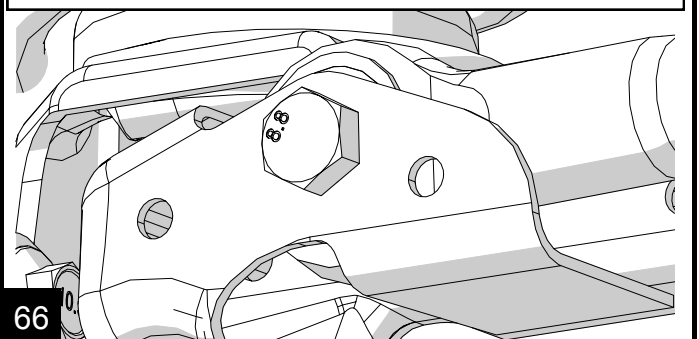

65

66

FRONT BRAKE LINE INSTALL

Remove the banjo bolt from the caliper with a 15mm.
TIP: Use a pan to catch the released fluid.

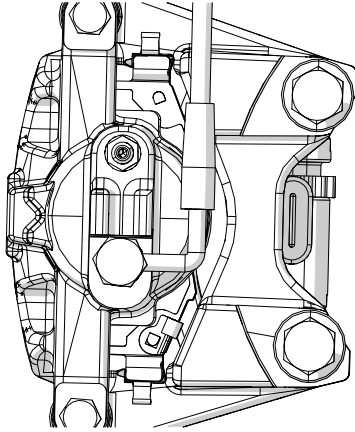

67

Remove the soft line from the hard line with a 12mm.
Remove the brake line from the frame with a 10mm.

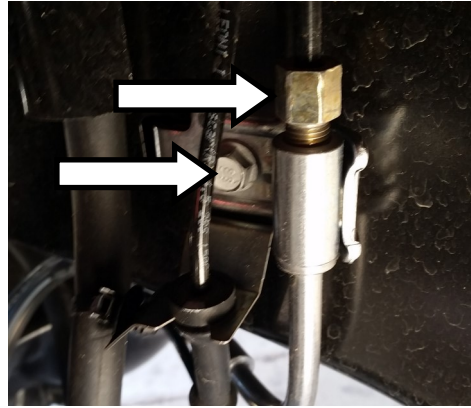

68

Mount the new L-brackets to the frame with the original bolt. Insert the new line through the bracket. Hand tighten the hard line into the new line.

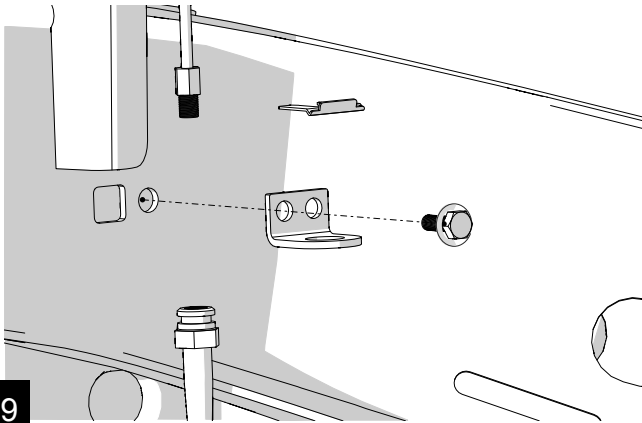

69

Place a new copper washer on the banjo bolt and insert through the end of the brake line. Place another copper washer between the fitting and the caliper.

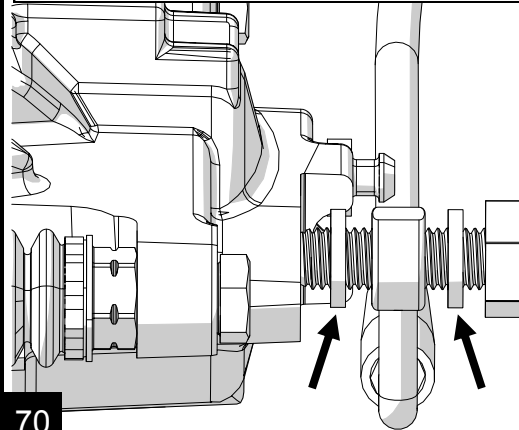

70

Orient the brake line as shown on the caliper.
Torque banjo bolt to 23 ft-lbs. Torque the hard line fitting to 14 ft-lbs and install the retainer clip.

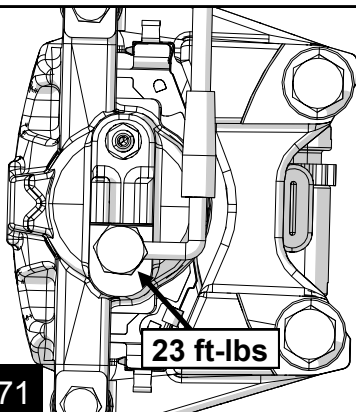

71

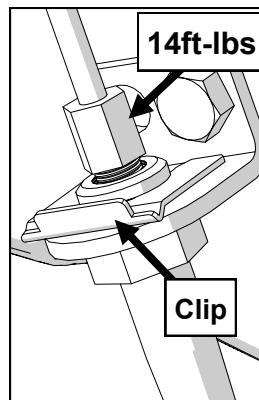

72

REAR BRAKE LINE INSTALL

Remove the banjo bolt from the caliper with a 15mm.
Use a pan to catch the released fluid.



72

Remove the brake line from the hard line with a 12mm. Remove the line from the frame with a 10mm.

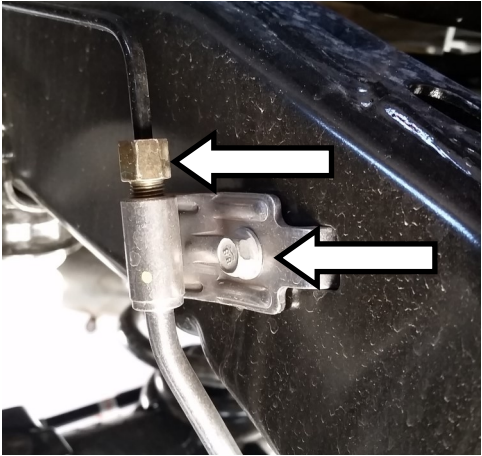

Install the new L bracket onto the frame with the original bolt. Insert the new line through the bracket. Hand tighten the hard line fitting into the new brake line.

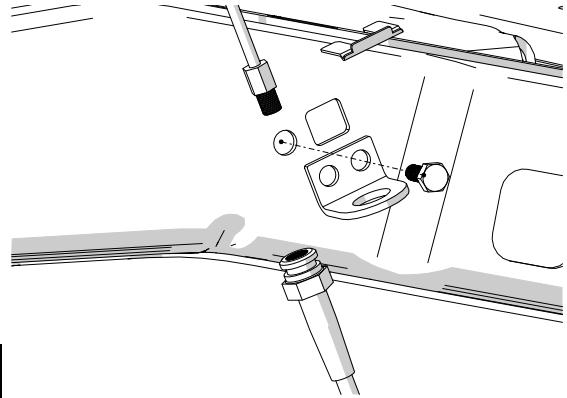

Place a new copper washer on the banjo bolt and insert through the end of the brake line. Place another copper washer between the fitting and the caliper.

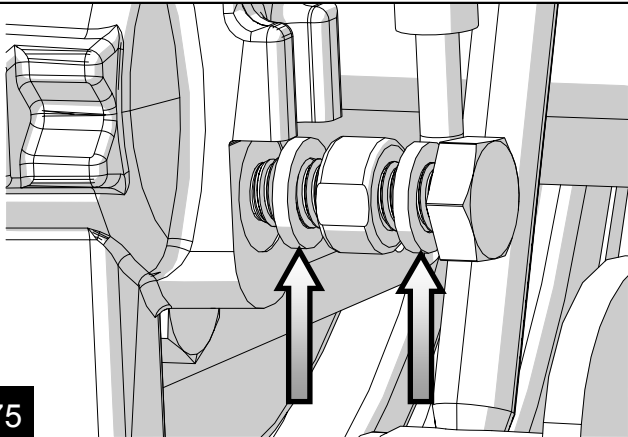

Orient the line as shown on the caliper.
Torque banjo bolt to 23 ft-lbs.

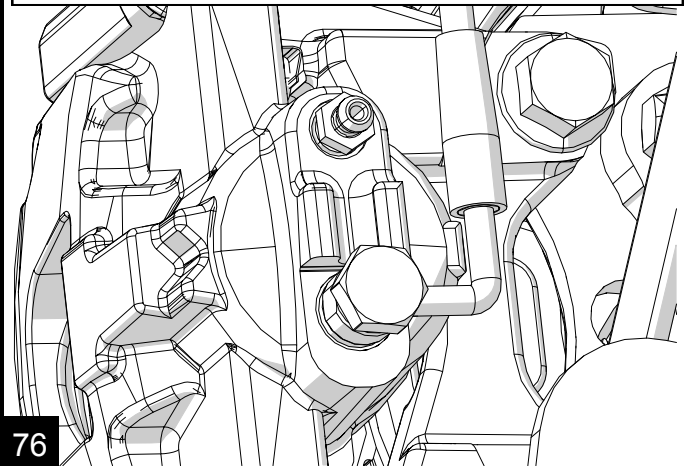

Make sure the brake lines will not snag on any components as the suspension cycles. **Tip:** Zip tie the soft brake line to the rear swaybar link (away from the tire).
Torque the hard line fitting to 14 ft-lbs and install the retainer clip.

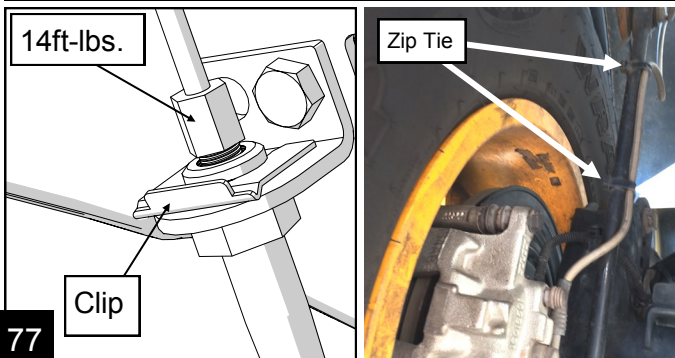

BLEED THE BRAKES

Bleed the brakes according to standard procedure. Starting with the rear right caliper, then right to left, and back to front.

78

INSTALLATION OF BRAKE LINE ANCHOR

Use some cable ties to route the ABS and brake lines together so they are uniform and equal.

NOTE: Zip ties provided in the kit are for mounting the brake lines to the Anchor. Extra cable ties can be picked up from just about any hardware or automotive store.

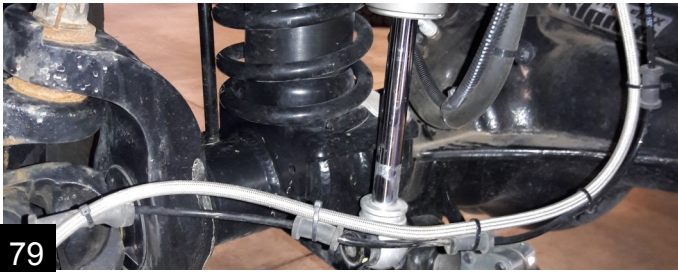

The Brake Line Anchor can be mounted on the inside or outside of the bottom shock mount bolt.

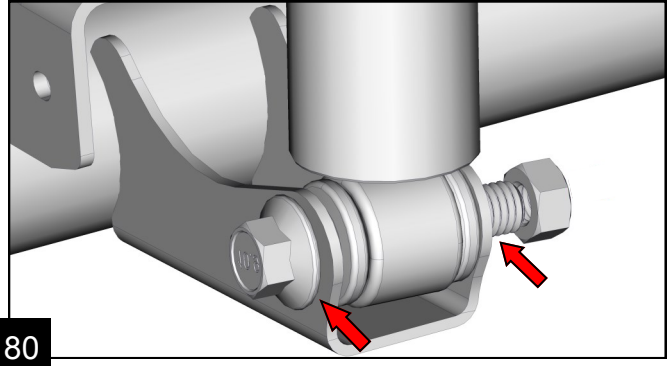

If there is plenty of length to your lines then mount the anchor on the inside, directly under the nut.
If your lines are stiff or length is an issue it might be better to install the anchor on the out side of the shock mount.

NOTES: *Use a large screwdriver or pry bar under the shock to help install shock mount bolt.*
Do not tighten the shock mount bolt

Once the anchor is installed then install the ABS line into the anchor followed by the brake line.
(see picture)

Next, *loosely* install a cable tie. Inspect the lines and adjust the line positions as needed.

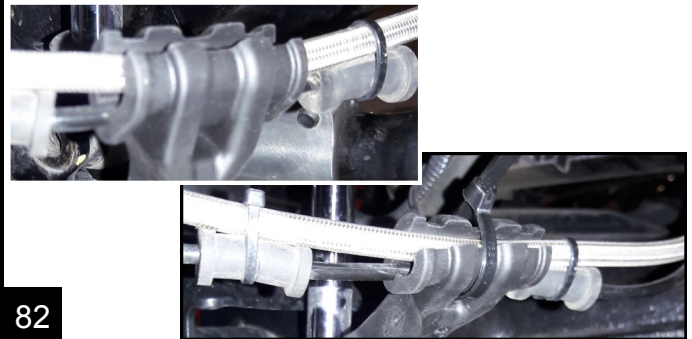
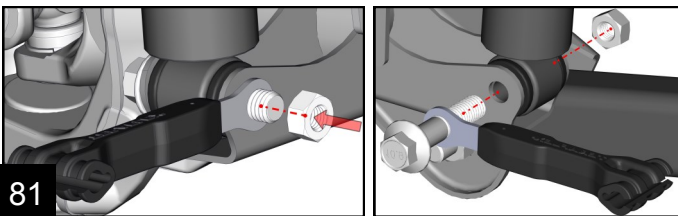

NOTE: We installed the lines so that the anchor was pulled slightly toward the tire when it was turned out. This was to help the lines stay clear of the tire when it is turned the opposite way.

Loosely install the rest of the cable ties.

Snug down the shock bolt.

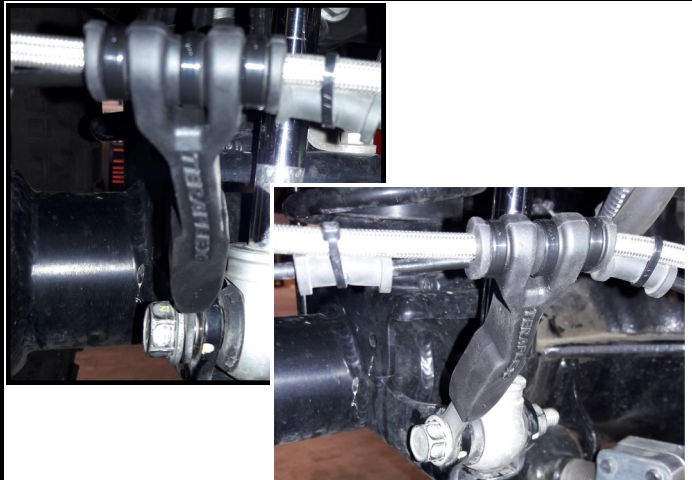

Repeat steps for the other side.

84

Test the position of the lines and anchor by turning the wheel from lock to lock and articulating the axle. With the shock bolt only snug the anchor can be rotated to help find the best angle (re-snug or loosen bolt as needed).



85

IMPORTANT NOTE! **Watch the anchor for clearance from the shock body.**

Once the best position is found, that keeps the brake lines safe from snags or damage, tighten and trim the zip ties and torque the shock bolts.
Torque to 56 ft. lbs. (76Nm)

86

2007-2011 4-DOOR AND ALL 2-DOOR JKs:
Skip to step 90.

EVAP CANISTER RELOCATE

2012+ 4-DOOR JKs: Must relocate the EVAP canister for proper driveline clearance at full suspension articulation.

Locate the EVAP canister and skid plate located under the vehicle next to the rear driveline. Use a 16mm to remove the two front bolts of the EVAP canister. Loosen, but do not remove the rear bolt.

87

Mark a centerline of the existing holes (labeled Line A). Mark a spot about half way between the two existing holes (labeled Point B) and one 50mm to the left of Point B. (labeled Point C). Center punch and drill a 1/2" hole at Points B and C. Use a small block of wood as a spacer behind the bracket for drilling.

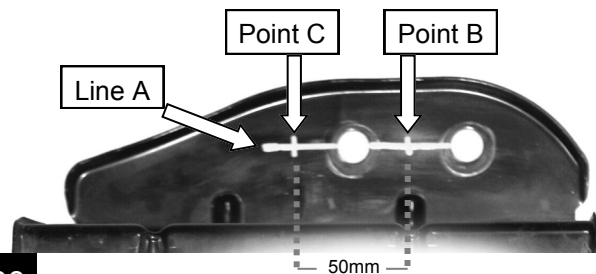

88

Remove the wood, rotate the canister and skid plate. Reinstall using the two new mounting holes. Torque all three bolts to 10 ft-lbs (14 Nm)

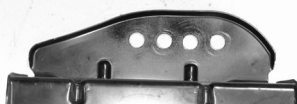

Results after drilling.



89

TOURQUE CONTROL ARM AND TRACK BAR BOLTS

Reinstall the wheels and tires. Torque lug nuts to factory recommended specs and lower the Jeep to the ground.

With the Jeep on the ground, torque the control arm and track bars bolts and any other bolts that have not been tightened yet. This ensures that bushing load is in a neutral position and will provide a longer bushing life.

Front and Rear Trackbars	125 ft-lbs	169Nm
Front Upper Control Arms	75 ft-lbs	102Nm
Rear Upper Control Arms	125 ft-lbs	169Nm
Front and Rear Lower Arms	125 ft-lbs	169Nm

90

Before test driving the Jeep, do a quick visual check and make sure the tires are straight. Adjust the drag link as needed to center the steering wheel. Drive a short distance down a straight road and, if necessary, readjust the steering wheel to center. Torque the drag-link adjusting sleeve to 26 ft-lbs (35 Nm).

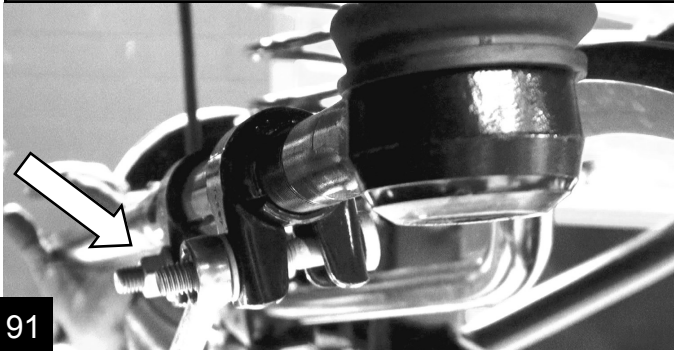

91

Perform a final check of the suspension components and bolts.

Important: Your Jeep will require a 4 wheel alignment to be road worthy.

After wheel alignment install the rear lower bumpstop pads.

92

REAR LOWER BUMP STOP PADS

All 4" and 6" lift kits come with an 6 additional Rear Lower Speedbump Pads. These are intended to be installed stacked together with the set provided in your Bump Stop Kit (4 PER SIDE). Make sure to follow the noted steps outlined in the Bump Stop Instructions.

Refer to the Bump Stop Instructions that came with lift kit for proper installation.

93

Install is now Complete

Maintenance Note: After the first 100 miles and every 3,000 miles after that, re-torque all the suspension components and bolts.

94



JK 4" Front and Rear Bumpstop Extension Kit

#1954625 JK 4" Bump Stop Extension Kit (Front / Rear)

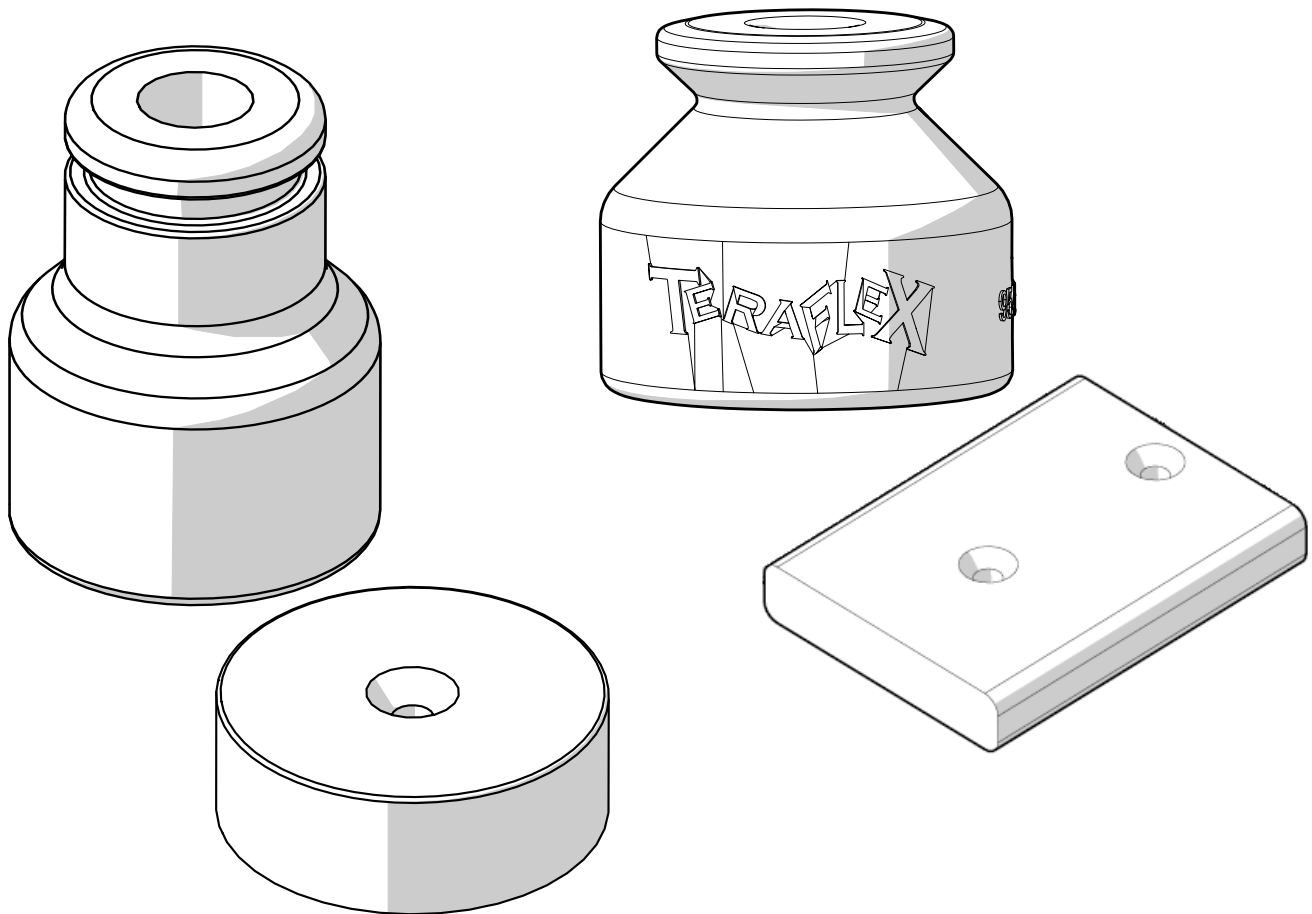

Important Notes:

Prior to beginning this or any installation read these instructions to familiarize yourself with the required steps and evaluate if you are experienced and capable to personally perform these modifications. A factory service manual should be used in conjunction with these installation instructions.

Refer to the parts list to ensure that all necessary components and hardware has been included. If any parts are missing please contact your local TeraFlex dealer for assistance.

The 4" Suspension Systems (Alpine CT4, Prerunner, 4" System with 8 Alpine Flexarms and Track Bar, and 4" Base Lift Kit) come with an addition of 2 Front (467125) and 6 Rear (954600) Lower Bumpstop Pads. For these 4" lift kits make sure to follow the noted steps outlined in these instructions for installation.

Tools needed:

- Basic mechanics tool set
- Allen Wrench - 3/16"
- Combination End Wrench - 1/2"

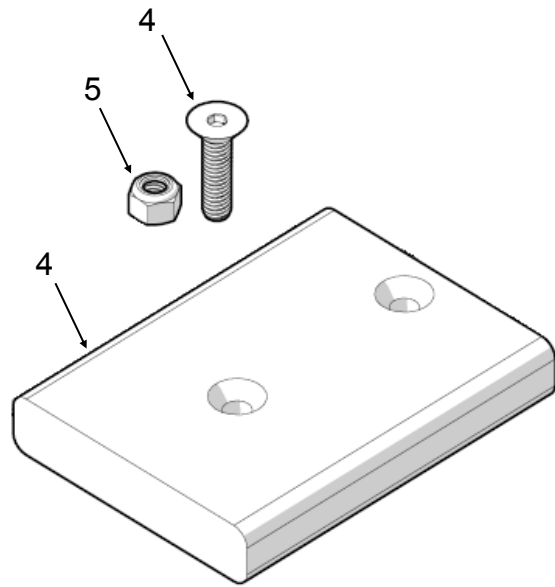
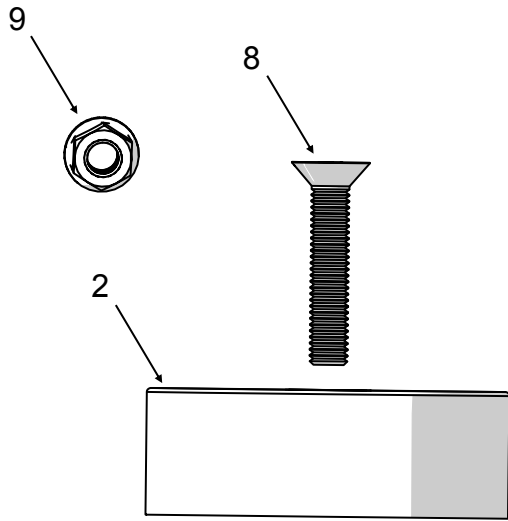
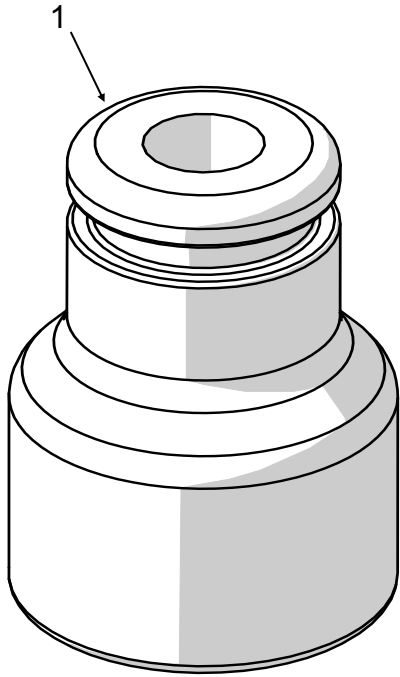

1954625 Bill of Material

Item #	Part Number	Description	QTY
1	953800	JK Front Upper Bumpstop Extension 2.75"	2
2	467125	Bumpstop JK Front 1.25" Tall x 3.5" OD	2
3	954802	JK Rear Upper Bumpstop Extension 2"	2
4	954600	JK Rear Lower 3/4" Tall Bumpstop Space	2
5	179	Bolt 5/16"-18 UNC x 1.25" Long Flat Head Socket Cap Screw	4
6	630	Nut 5/16"-18 UNC Nylock Zinc Plated	4
8	315	Bolt 3/8"-16x2" Flat Head Socket Cap	2
9	85	Nut 3/8"-16 Flanged Serrated	2

Refer to the factory service manual for safe lift locations. Raise and support the vehicle. Remove the tires and wheels and support the front axle with a jack or jack stands.

1

FRONT SPING REMOVAL

Remove the front track bar *at the axle* with a 21mm.

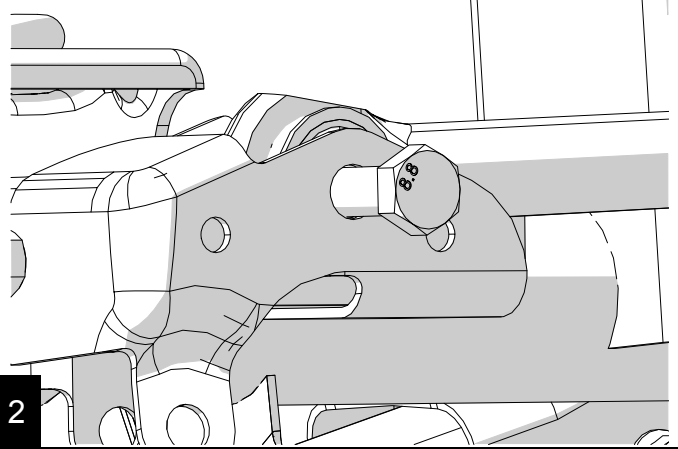

2

Remove the shocks *at the axle* with an 18mm.

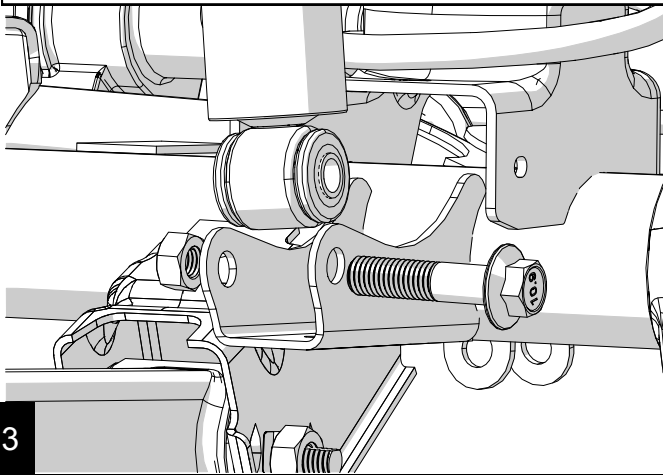

3

Remove the swaybar links *at the axle* with an 18mm.

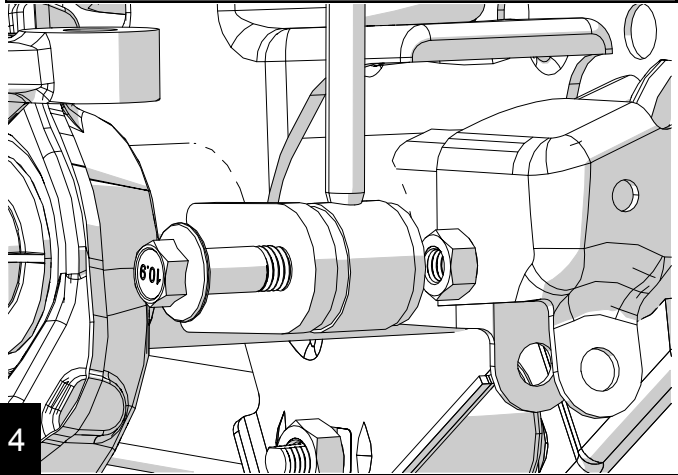

4

Lower the axle and remove the springs. **Be sure to check for any lines that can be pulled or damaged.**

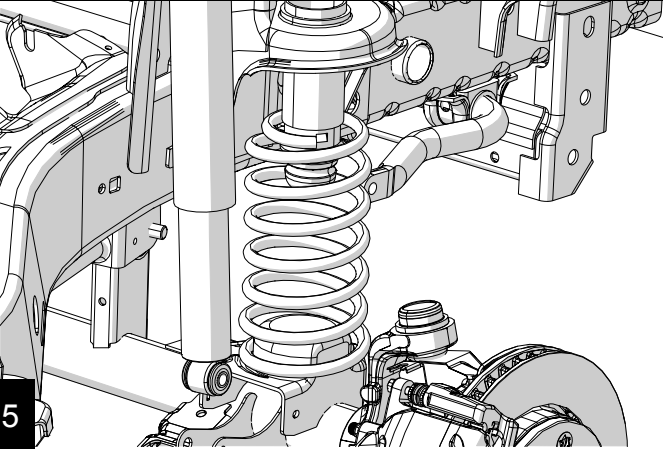

5

REMOVE FRONT FACTORY BUMP STOPS
Remove the factory bumpstop from the jounce tube by working it back and forth while twisting and pulling to the sides.

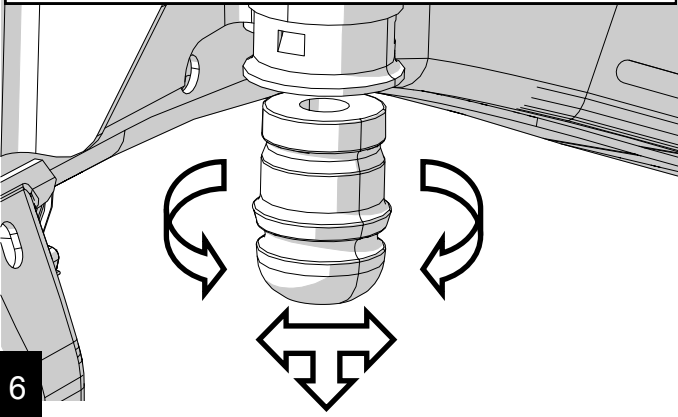

6

FRONT UPPER INSTALLATION

Install the bumpstop and extension by aligning the bumpstop, extension, and jounce tube. Use the hydraulic jack and raise the axle until they are seated together. A grease coating will help.

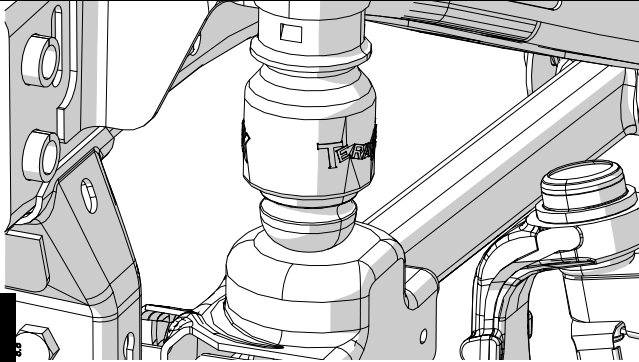

FRONT LOWER SPEEDBUMP BUMPSTOPS

Locate the center of the front axle driver and passenger side spring pads and drill a 3/8" [9.5mm] hole in the center of the pad.

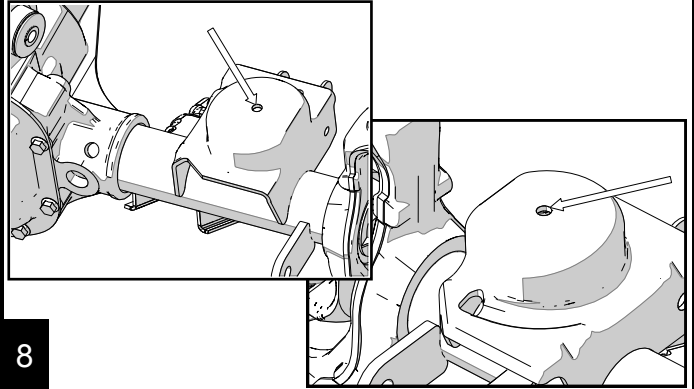

Reinstall the springs and the 467125 Speedbump Bumpstop at the same time so the spring is easier to install.

NOTE: For the 4" lift kits install the additional Speedbump Bump Stop provided in kit that came with your springs.

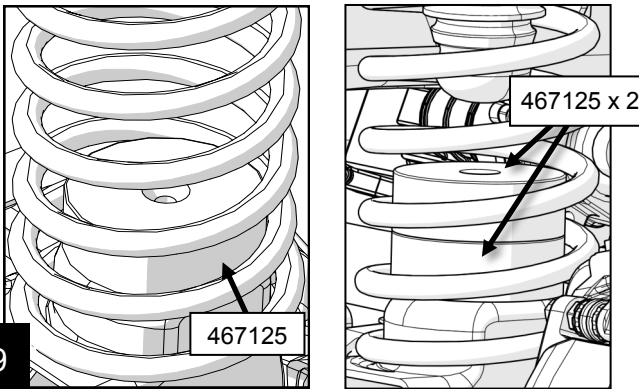

TIP: To help install the 467125 Speedbump Bumpstops along with the spring, use a long zip tie or wire to secure the bump stops inside the spring. Once the spring is in place, cut the zip tie or wire to release the bump stops once spring is in place.

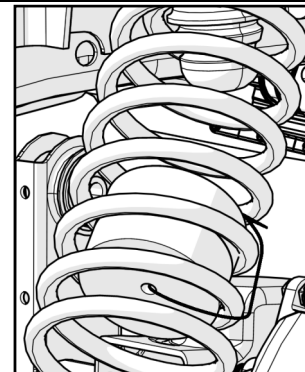

Install the #315 3/8" x 2" bolt through the bump stop and the #85 3/8" nut under the spring pad. Tighten bolt.

NOTE: For the 4" lift kits install the longer #3151 3/8" x 3" bolt provided in the hardware kit that came with your springs.

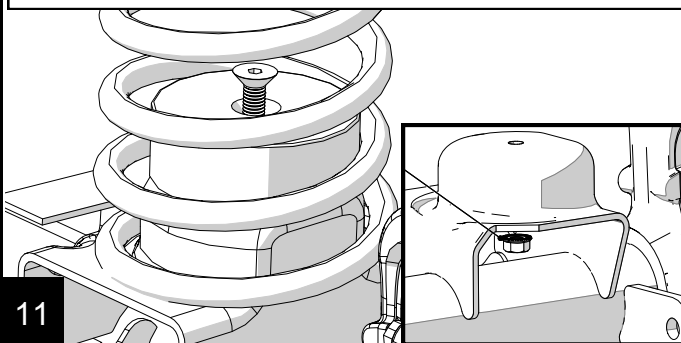

Reinstall the shocks, if not replacing shocks, or install the new shocks (Refer to instruction that came with your shocks).

Torque lower bolts to 56 ft-lbs.
Reinstall the swaybar links to the axle.
Torque to 75 ft-lbs.

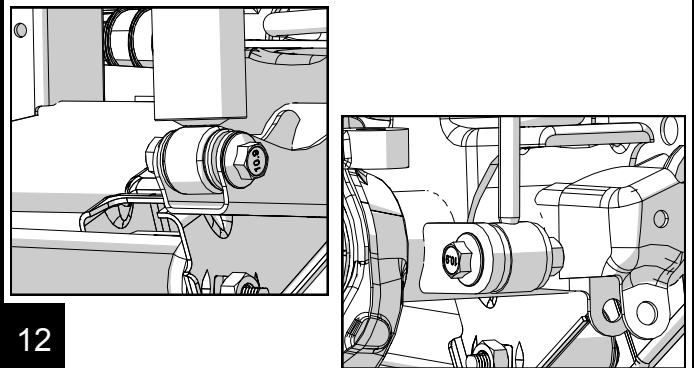

REMOVE REAR FACTORY BUMP STOPS

Remove the factory bumpstop from the cup on the frame by working it back and forth while twisting and pulling to the side.

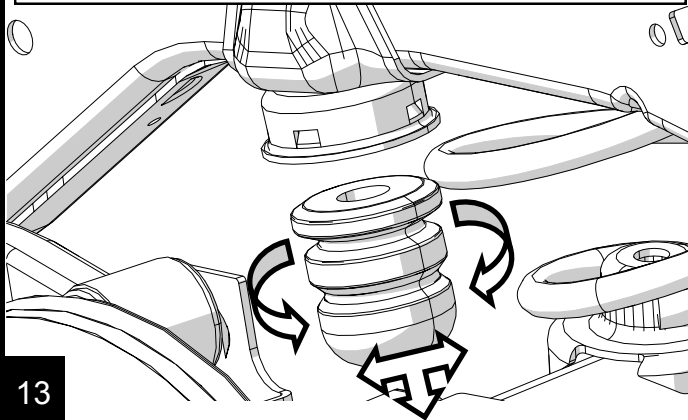

13

REAR UPPER INSTALL

Apply grease to the bumpstop and the extension.

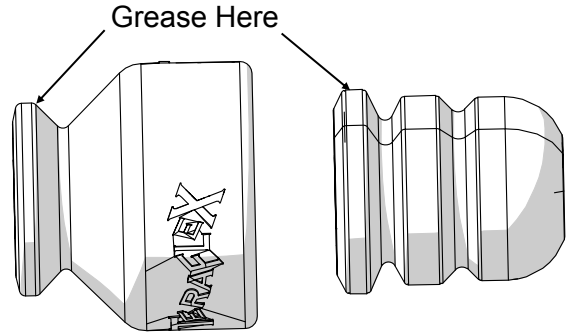

14

Align the bumpstop, extension and frame cup. Place a block between the frame and the axle bump pad. Raise the axle with a jack until the bumpstop and extension seat.

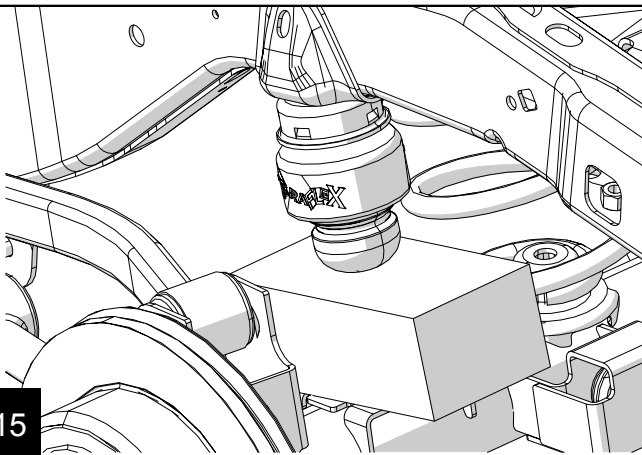

15

REAR LOWER INSTALL

Locate the rear lower bumpstop pad (954600) and position pad with the extended end facing the front of the Jeep.

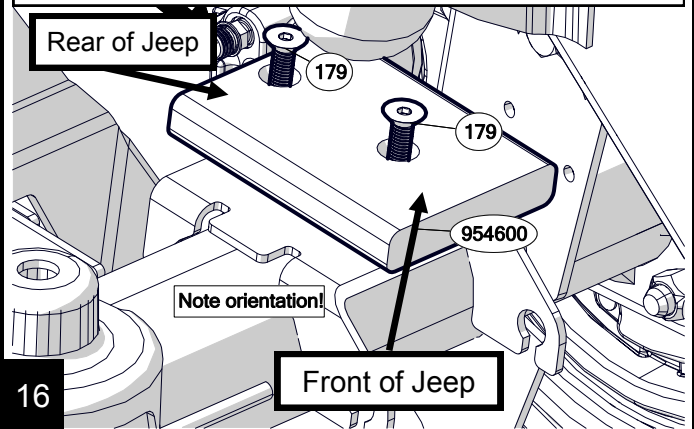

16

NOTE: For the 4" lift kits locate the 6 rear lower bumpstop pads (954600) that came with your spring box and the other 2 that came with this Bump Stop kit (8 total). Position 4 pads (per side) with the extended side facing the front of the Jeep, as shown.

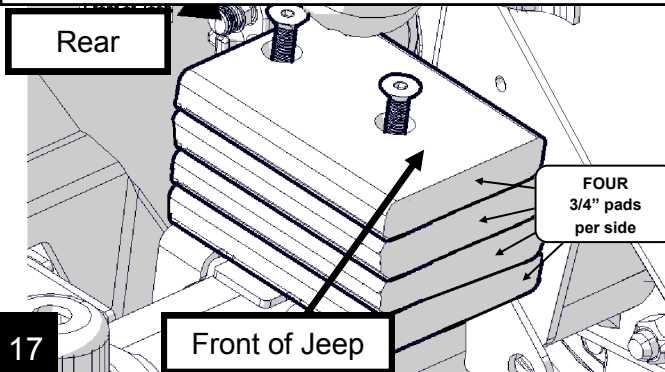

17

Each side will receive two (179) bolts and two (630) nylock nuts. Finish up the installation by torquing each of the 4 bolts to 7 ft-lbs (9.5 Nm).

NOTE: For the 4" lift kits install the longer #1000 5/16" x 3.5" bolts provided in the hardware kit that came with your springs. A set of 5/16" x 2.75" bolts have also been provided in the spring hardware for those wanting to do 3 pads per side instead of the 4. It is best to start with 4 per side first and then fine tune from there by cycling the suspension.

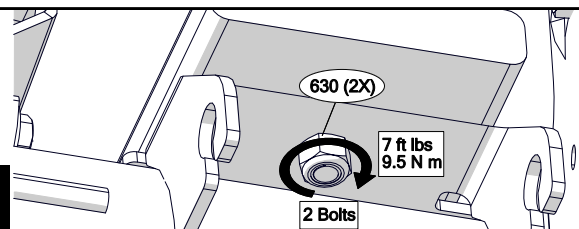

18

IMPORTANT NOTE!

Due to clearance issues with the bumpstop pad on the axle it is important to have the frame side factory trackbar bolt installed from the front, and the nut to the rear.

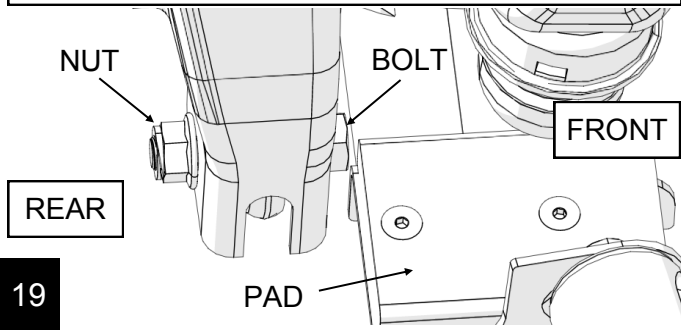

Refer back to the lift instructions now or reinstall the tires, remove supports and lower Jeep to the ground. Reinstall the front trackbar and torque to 125 ft-lbs.

