



# Jeep JL 1.5" Spacer Lift

Kit #1165100 - Jeep JL Wrangler, 2DR 1.5" Spacer Lift Kit

Kit #1165002 - Jeep JL Wrangler, 2DR ST1, No Shocks

Kit #1165121 - Jeep JL Wrangler, 2DR S/T1 Kit, 2.1 Falcon Shocks

Kit #1165200 - Jeep JL Wrangler, 4DR 1.5" Spacer Lift

Kit #1165000 - Jeep JL Wrangler, 4DR ST1, No Shocks

Kit #1165021 - Jeep JL Wrangler, 4DR S/T1 Kit, 2.1 Falcon Shocks

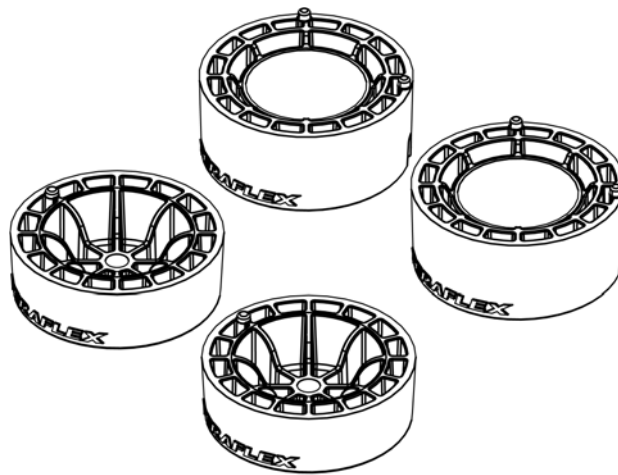

## IMPORTANT NOTES:

Prior to beginning this install, or any installation, *read the instructions thoroughly* to familiarize yourself with the required steps. Evaluate if you are experienced and capable to personally perform these modifications. A factory service manual should be used in conjunction with these installation instructions.

This product will change the highway handling characteristics of your vehicle, exercise caution. After altering the suspension it is always advisable to have an alignment done by a competent 4 wheel drive shop or by an alignment shop that is experienced with lifted 4 wheel drive vehicles.

Refer to the parts list to ensure that all necessary components and hardware has been included.







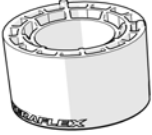

**Refer to the factory service manual for the torque specs of the originally equipped hardware.**

## TOOLS NEEDED:

- This installation guide
- Basic mechanics tool set
- Factory Service Manual

## MAINTENANCE INFORMATION:

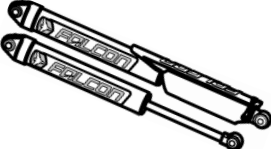
It is the buyer's responsibility to have all suspension, drivetrain, steering, and other components checked for proper tightness and torque after the first 300 miles and every 3000 miles after that.

Item #	Description	Part No.	Base Kit		S/T1		S/T1 w/o Shocks	
			2DR	4DR	2DR	4DR	2DR	4DR
1		05-01-109-100	-	2	-	2	-	2
		05-01-109-200	2	-	2	-	2	-
2		05-01-209-150	2	2	2	2	2	2
3		23-07-03-001	2	2	2	2	2	2
4		45-01-003-006	2	2	2	2	2	2
5		45-04-003-001	2	2	2	2	2	2
6		47-02-001-001	2	2	2	2	2	2
7		11-01-21-400-000-3	-	-	1	1	-	-
8		1959200	-	-	1	1	1	1

### LIFT AND SUPPORT AT FRAME

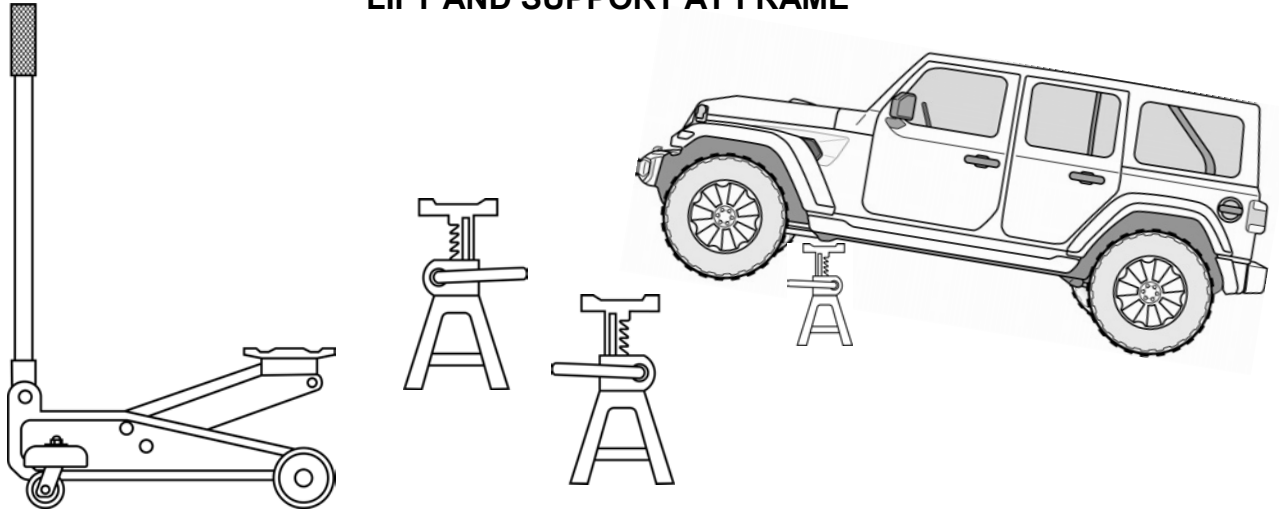

### REMOVE TIRES & WHEELS

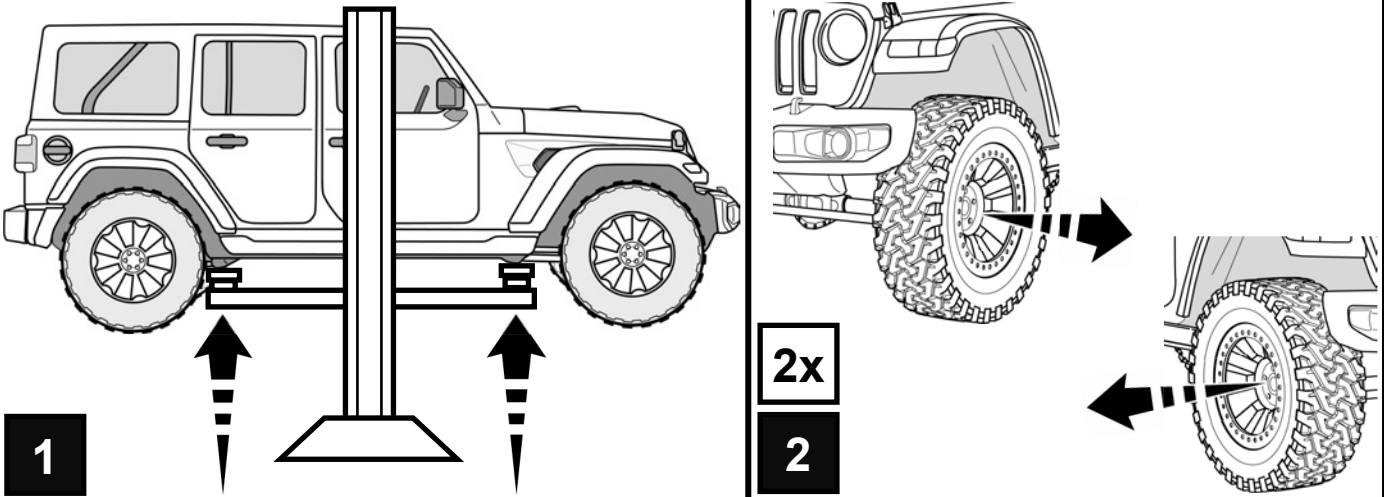

### SUPPORT FRONT AXLE

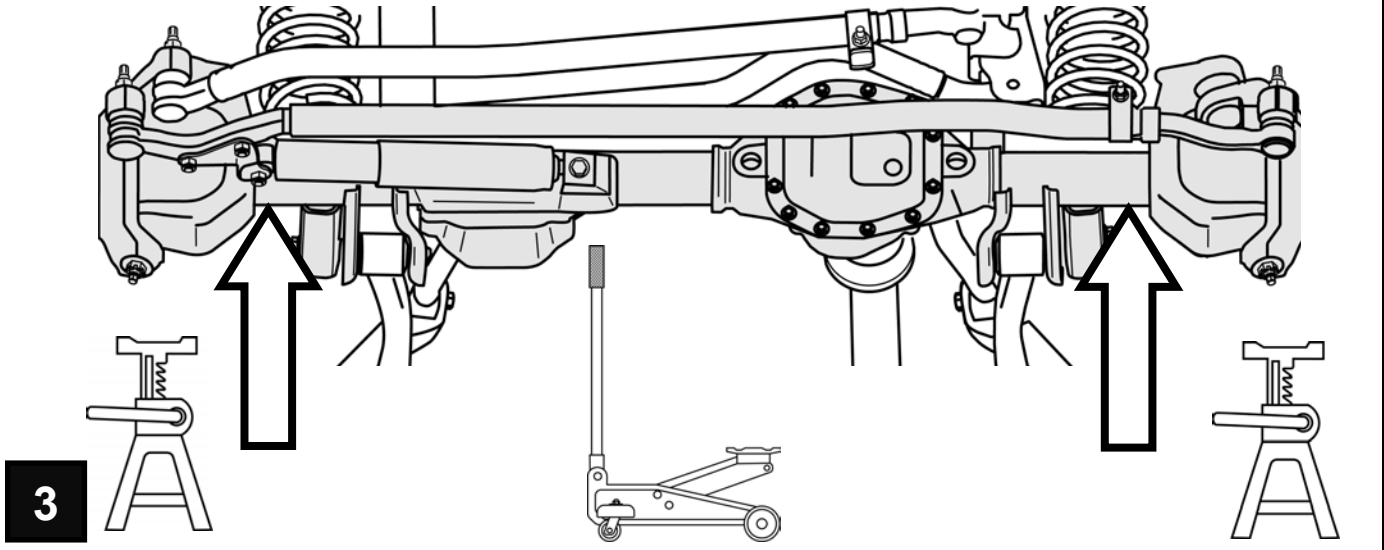

**REMOVE SWAY BAR LINK & TRACK BAR AT THE AXLE**

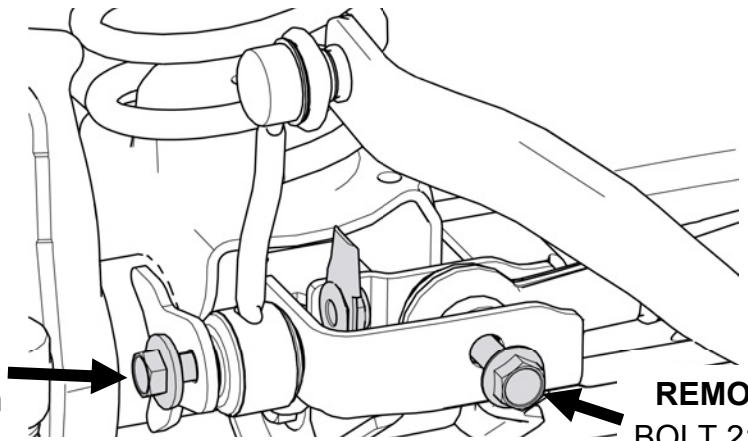
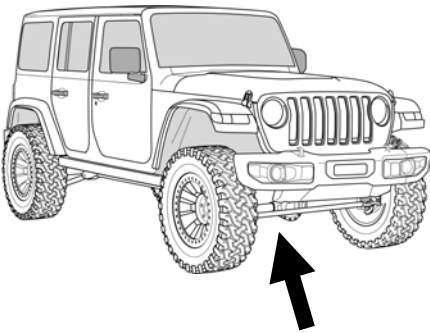

**4**

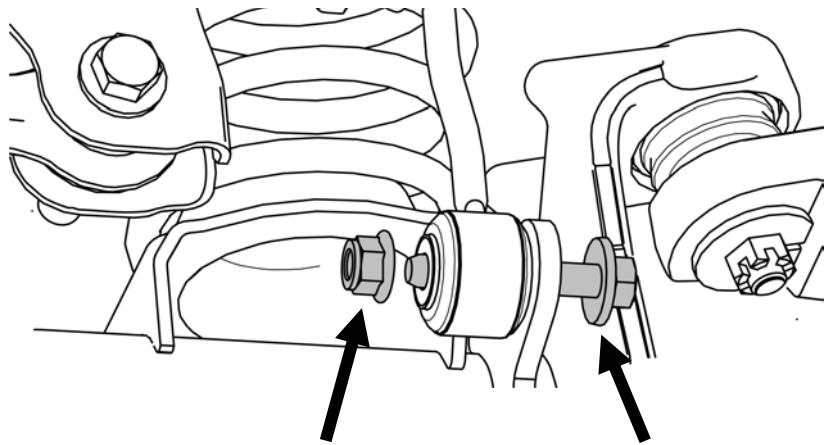
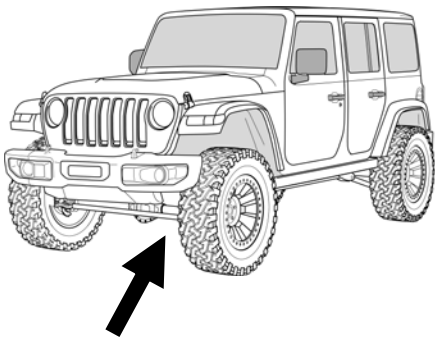

**5**

**REMOVE & DISCARD BRAKE LINE BRACKETS FROM LOWER CONTROL ARMS**

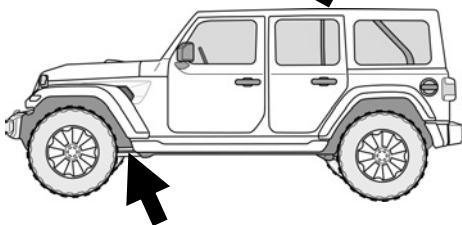
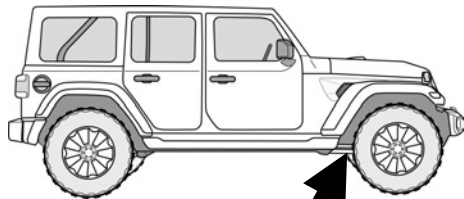

**2x**

**6**

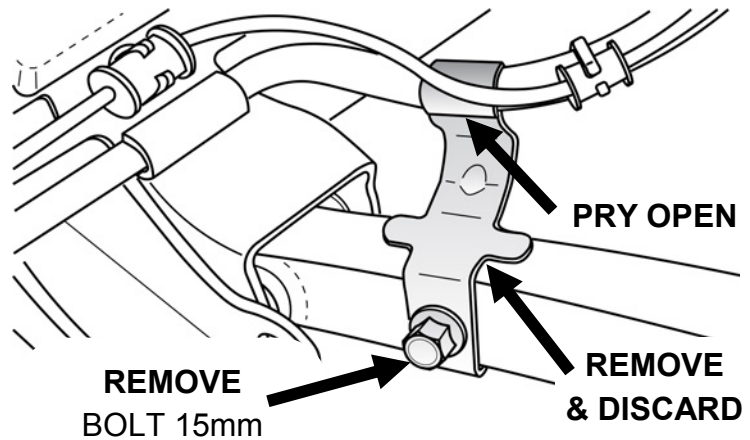

**DISCONNECT ACTUATORS AND VENT HOSE AT THE FRONT AXLE**

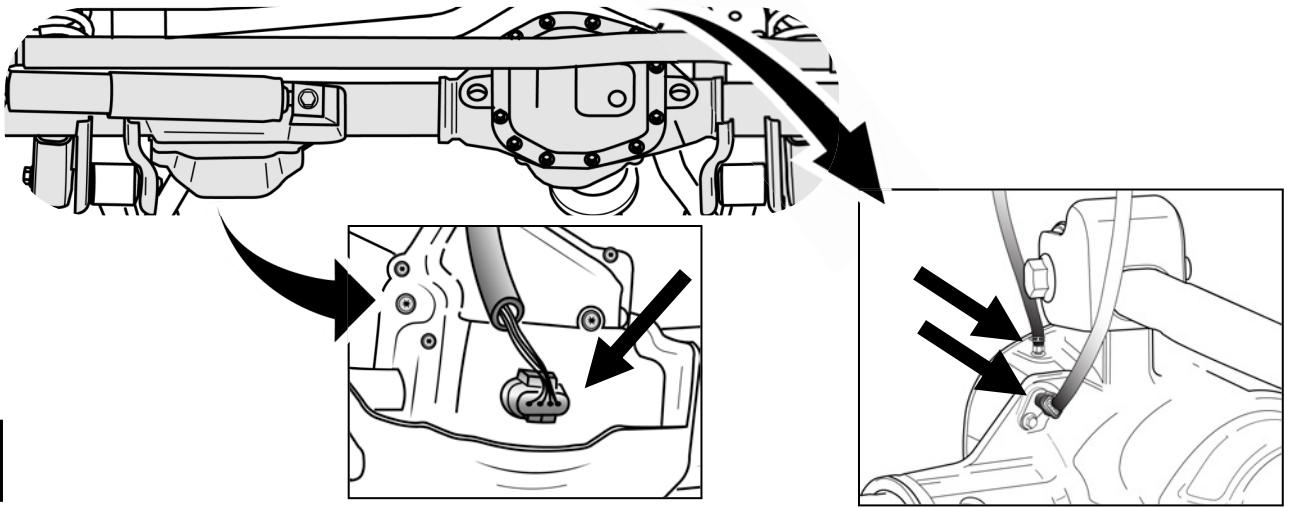

**7**

**LOOSEN FRONT CONTROL ARM BOLTS**

**NOTE: DO NOT REMOVE THE CONTROL ARM BOLTS**

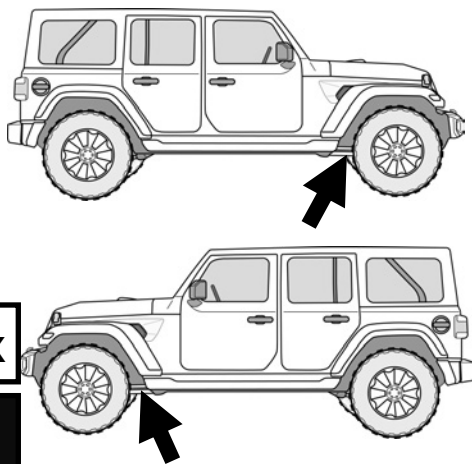

**2x**

**8**

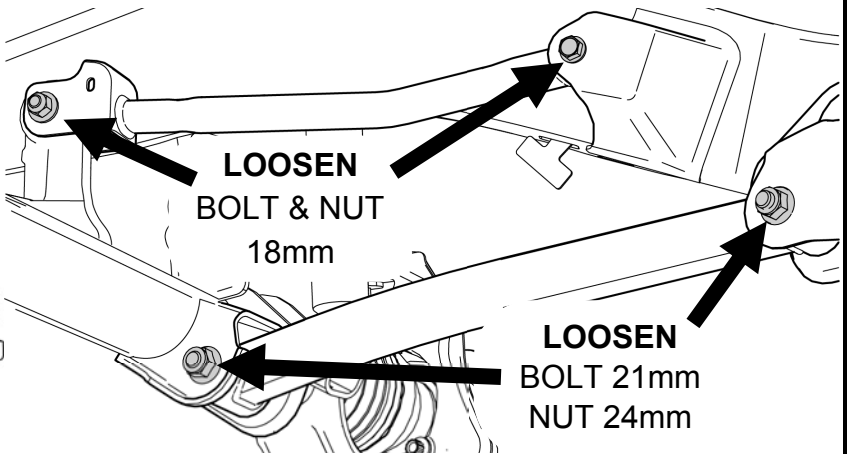

**LOOSEN  
BOLT & NUT  
18mm**

**LOOSEN  
BOLT 21mm  
NUT 24mm**

**REMOVE SHOCKS AT THE AXLE**

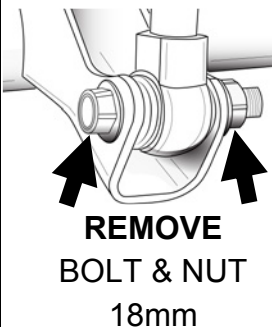

**REMOVE  
BOLT & NUT  
18mm**

**\*IF REPLACING\*  
\*SHOCKS\*  
REMOVE UPPER  
BOLT 18mm**

**2x**

**9**

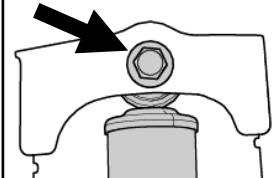

**LOWER AXLE & REMOVE SPRINGS**

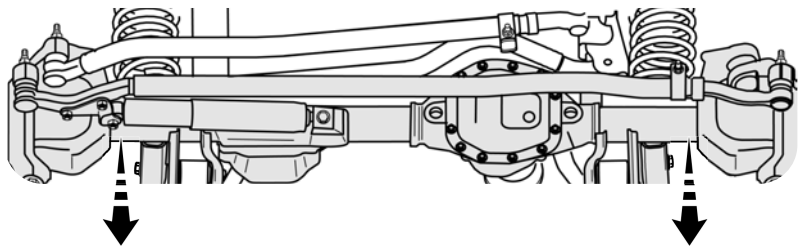

**NOTE: REMOVE ANY  
PLASTIC RETAINERS  
FROM WIRING OR  
HOSES AS NEEDED.**

**2x**

**10**

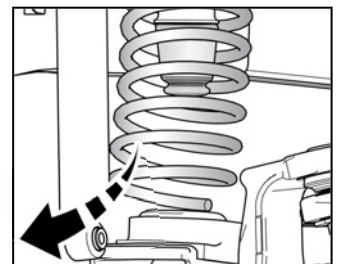



### INSTALL SPRING SPACER & FACTORY SPRING ISOLATOR ONTO JOUNCE TUBES

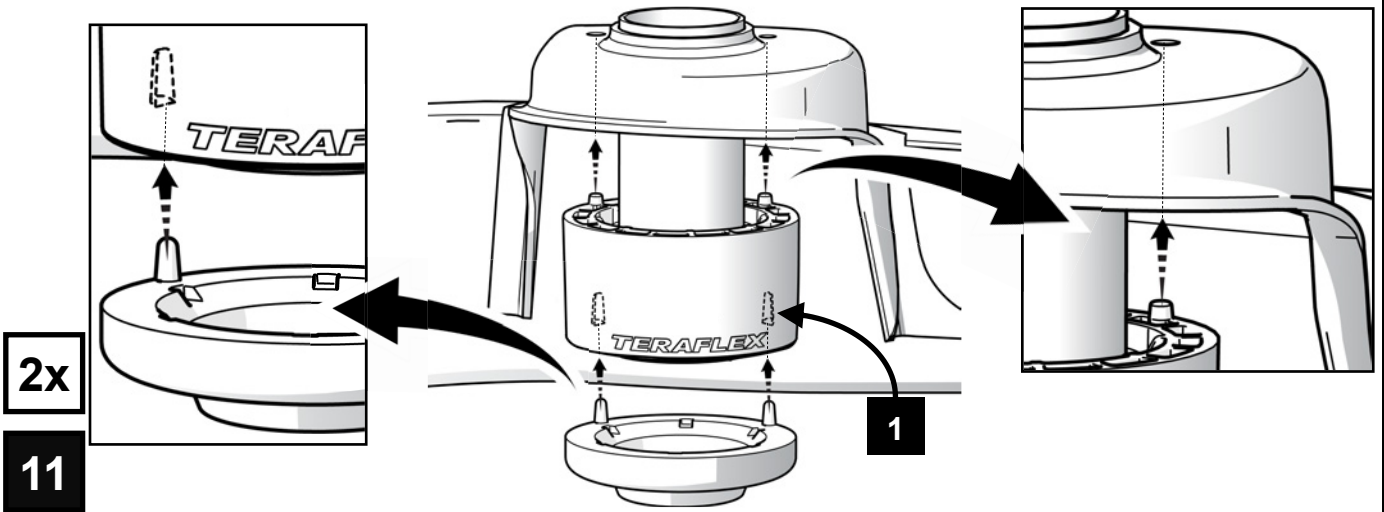

### REINSTALL THE SPRINGS

**NOTE: IF INSTALLING FALCON JOUNCE BUMPERS REFER TO INSTRUCTION #999308 BEFORE INSTALLING SPRINGS**

2x  
12

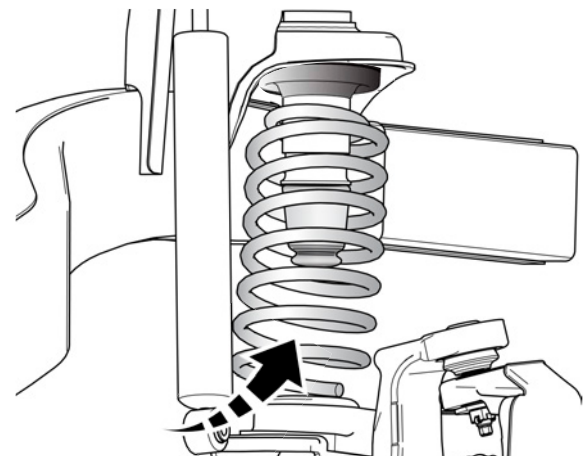

### SEAT SPRINGS INTO LOWER SPRING ISOLATOR

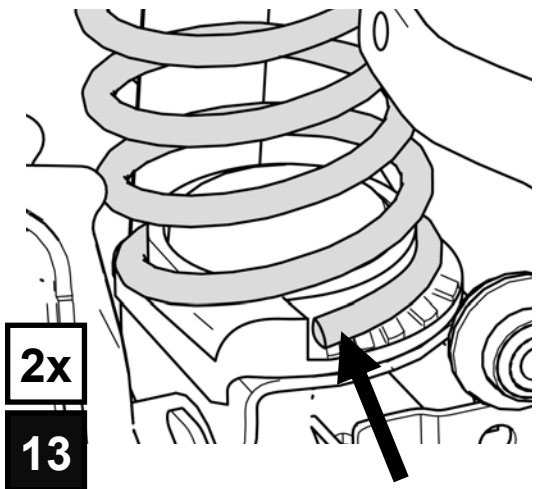

### RAISE AXLE & INSTALL SHOCKS

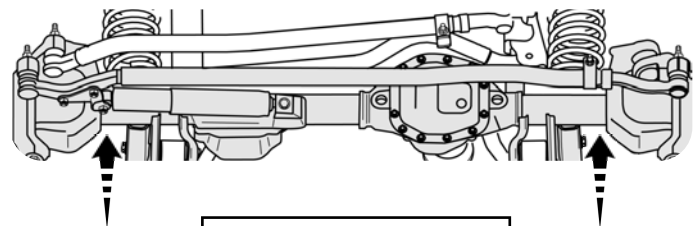

**TORQUE  
56 FT - LBS.  
BOLT & NUT 18mm**

**RECONNECT ACTUATORS AND VENT HOSE TO FRONT AXLE**

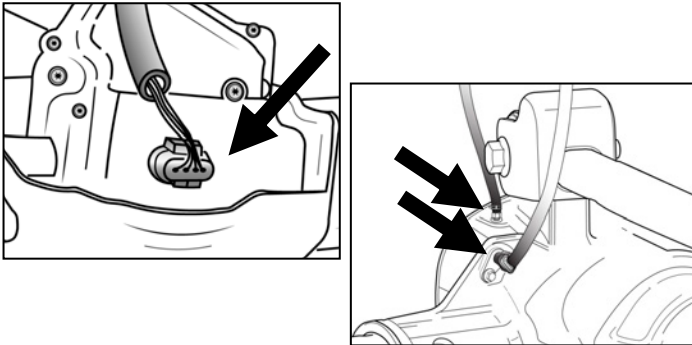

**NOTE: DO NOT TIGHTEN THE CONTROL ARM BOLTS UNTIL THE JEEP IS ON THE GROUND**

**14**

**RECONNECT PLASTIC RETAINERS FROM WIRING OR HOSES AS NEEDED**

**NOTE: IF ONLY FRONT OF JEEP WAS LIFTED REINSTALL TIRES & WHEELS AND LOWER JEEP BACK TO THE GROUND BEFORE LIFTING THE REAR**

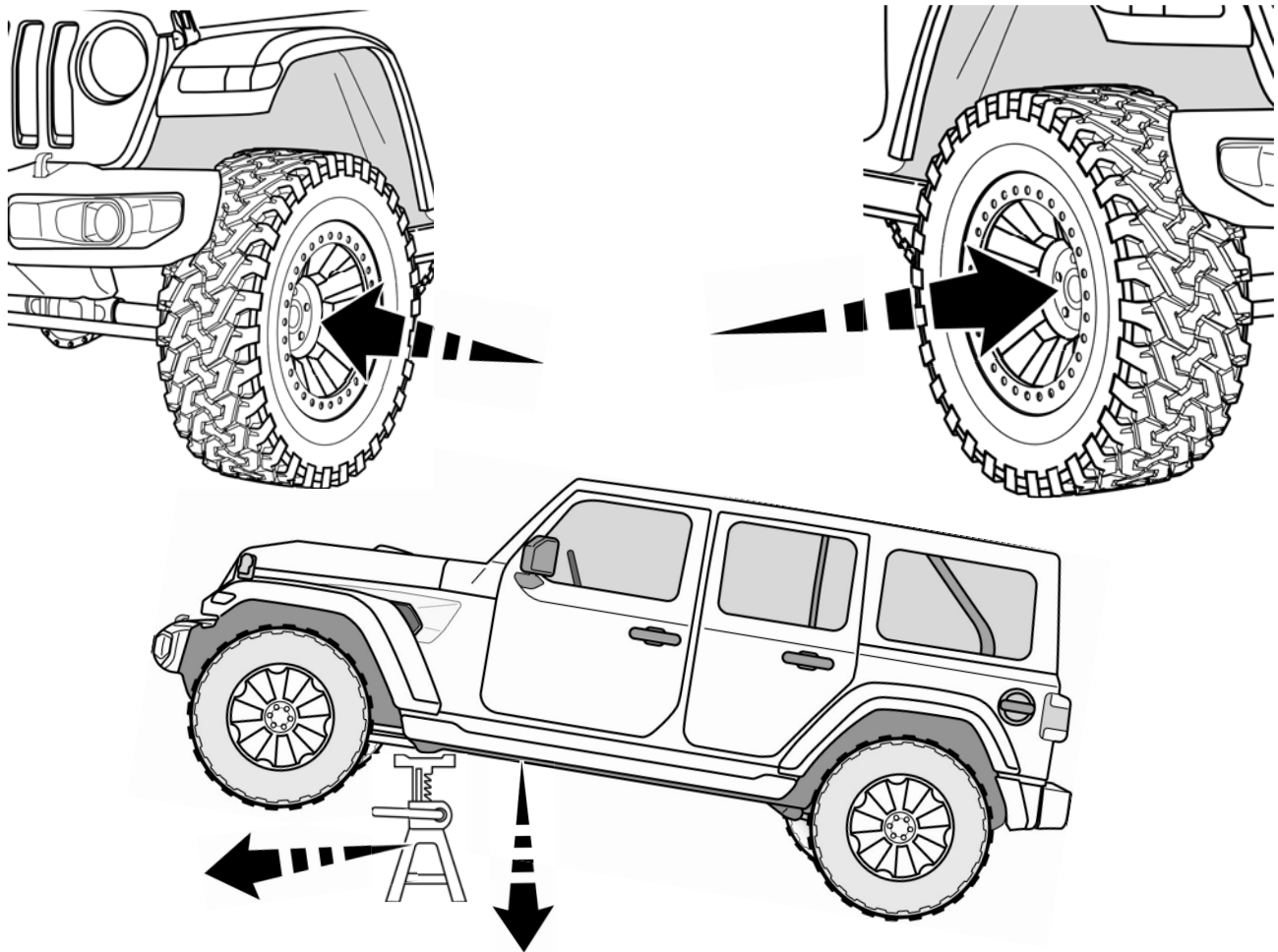

### LIFT AND SUPPORT AT FRAME

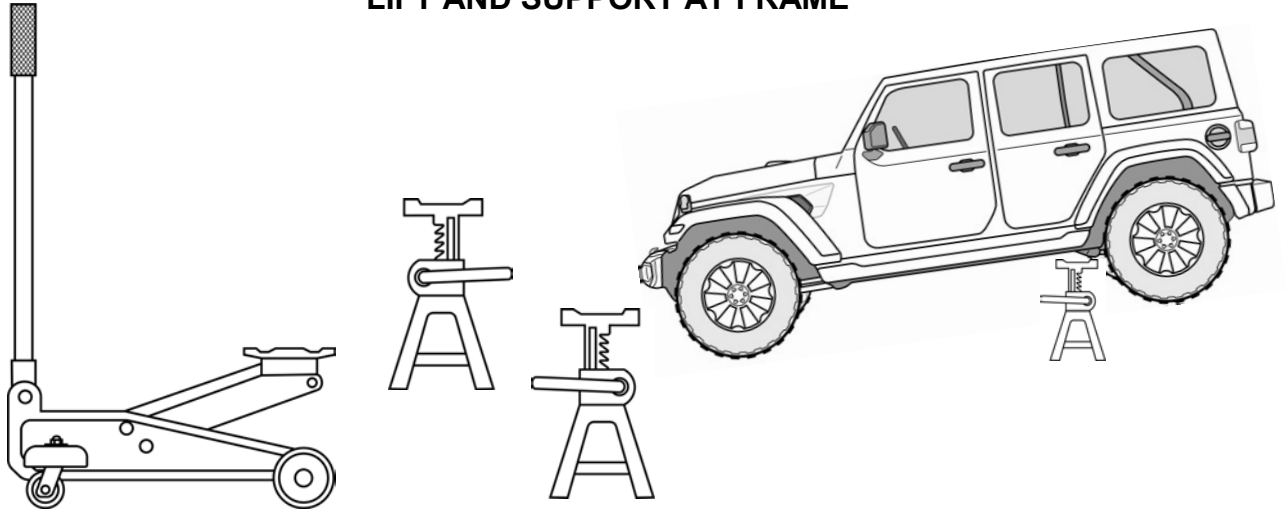

### REMOVE TIRES AND WHEELS

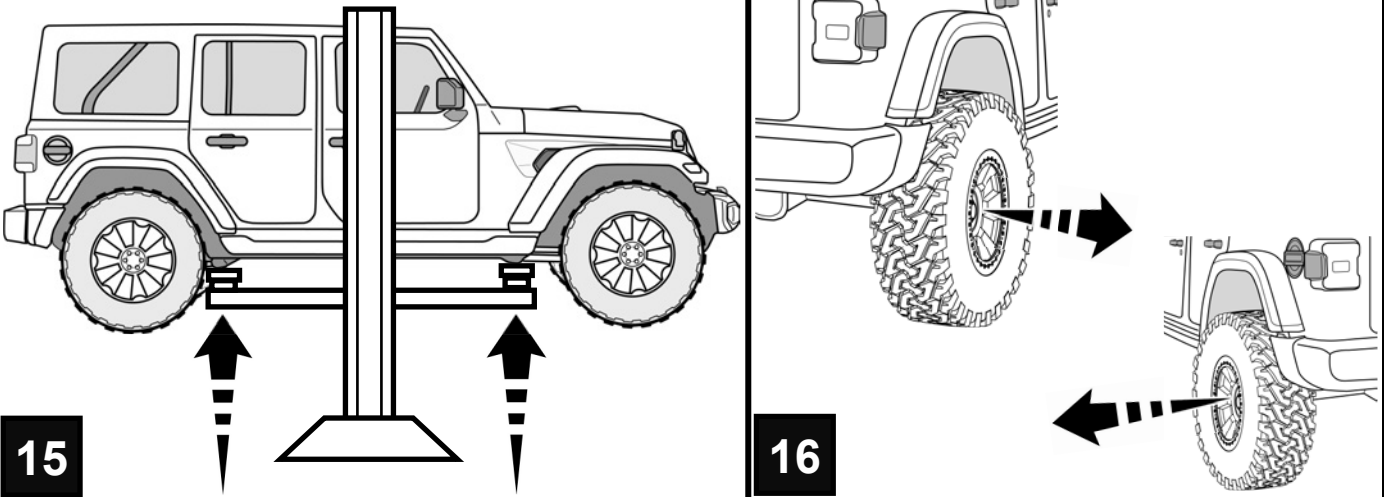

### SUPPORT REAR AXLE

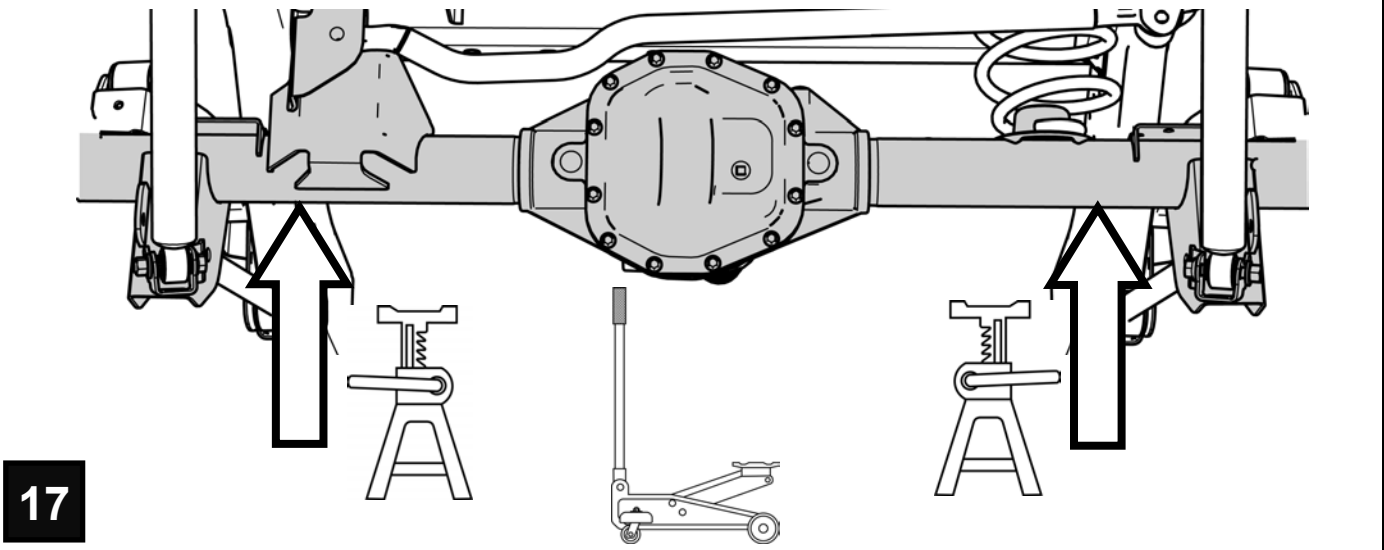



**REMOVE E-BRAKE CABLE BRACKET AND DISCARD**

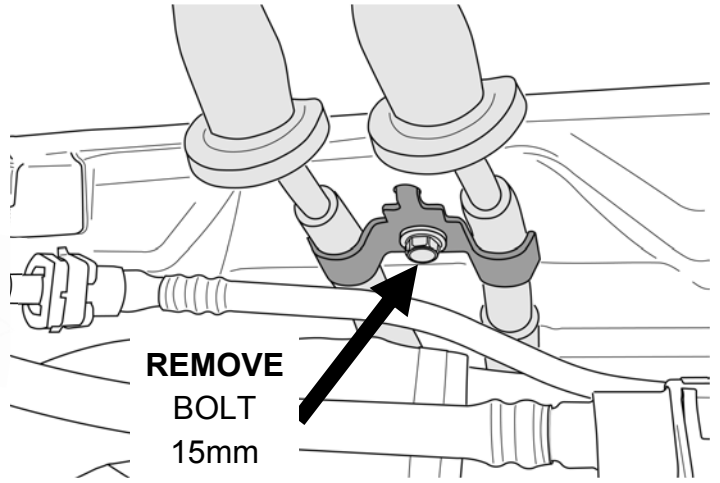
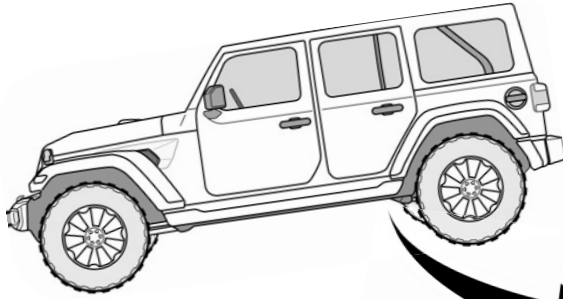

**REMOVE  
BOLT  
15mm**

**18**

**LOOSEN REAR CONTROL ARM BOLTS**

**DO NOT REMOVE THE CONTROL ARM BOLTS**

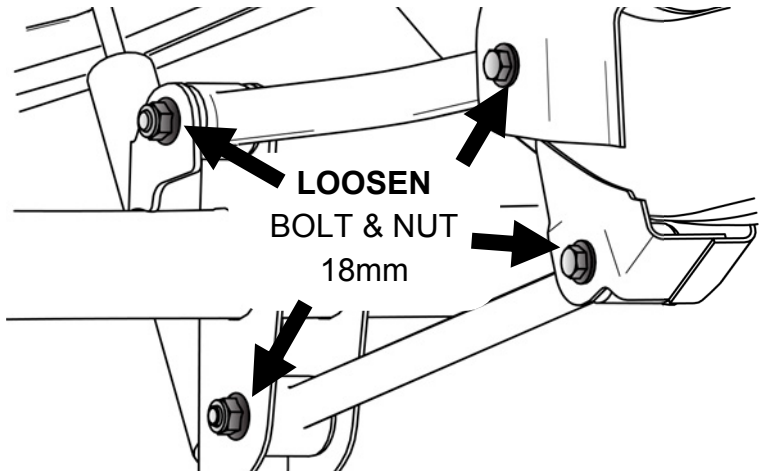
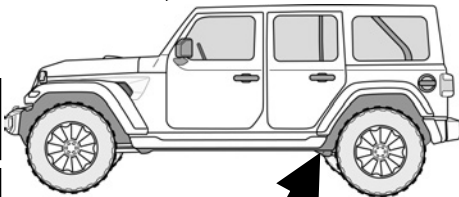
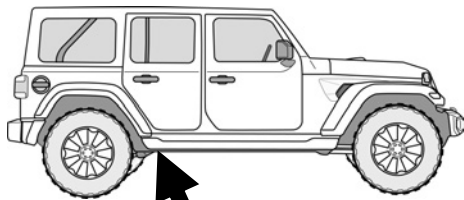

**LOOSEN  
BOLT & NUT  
18mm**

**2x**

**19**

**REMOVE SWAY BAR LINKS AT THE AXLE**



**REMOVE  
BOLT & NUT  
18mm**

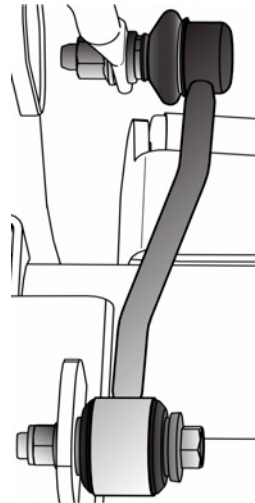

**REMOVE  
BOLT & NUT  
18mm**

**26**

**2x**

### REMOVE BRAKE LINE BRACKETS FROM AXLE

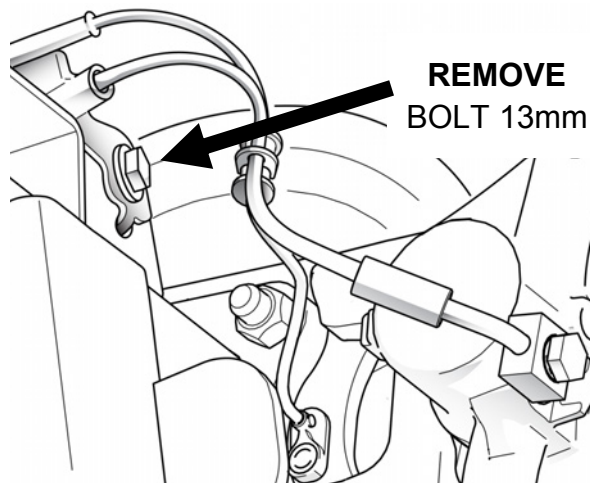
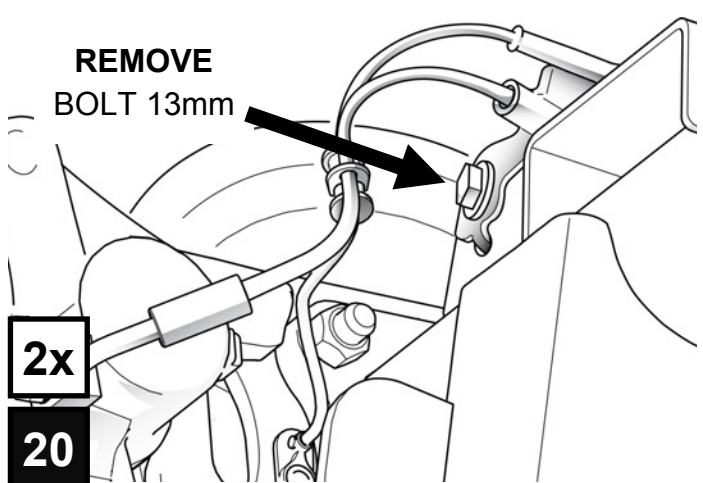

### REMOVE THE TRACK BAR FROM THE AXLE

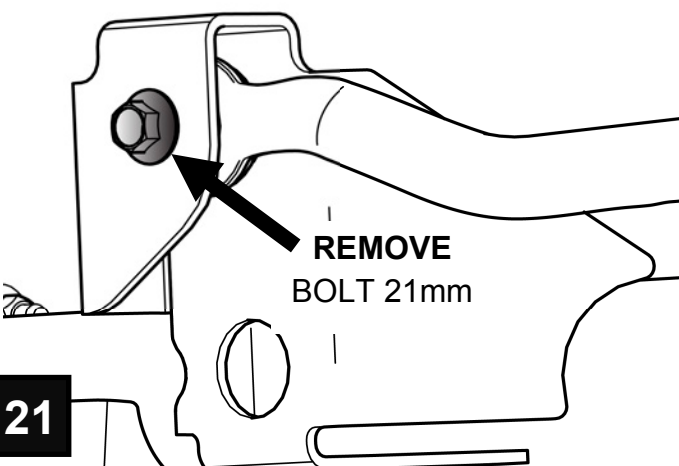

### REMOVE SHOCKS AT THE AXLE

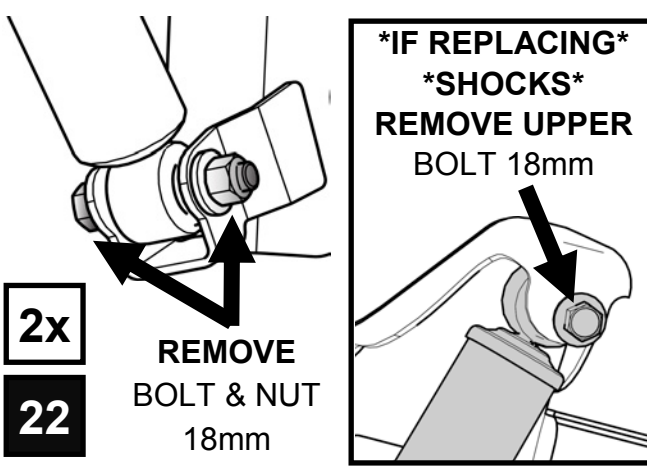

### LOWER AXLE & REMOVE THE SPRINGS

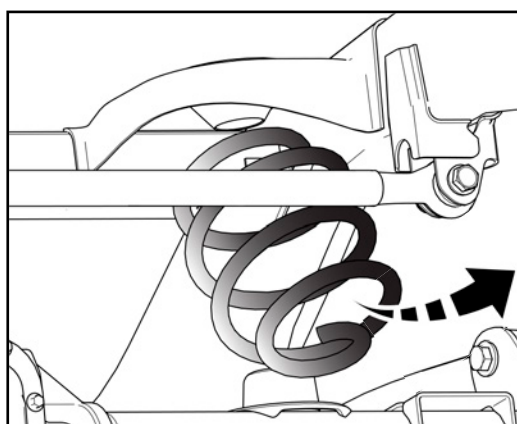
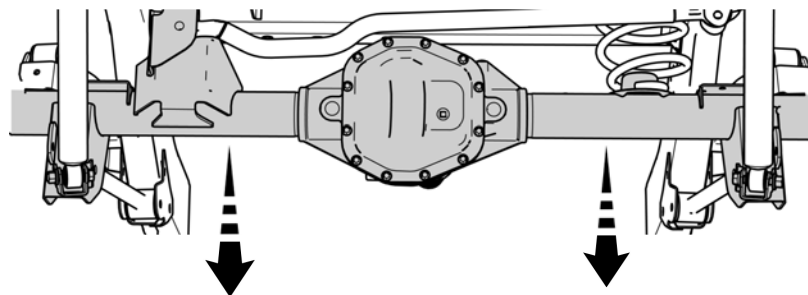

**NOTE: REMOVE ANY PLASTIC RETAINERS FROM WIRING OR HOSES AS NEEDED.**

### INSTALL REAR SPRING SPACER AND FACTORY SPRING ISOLATOR

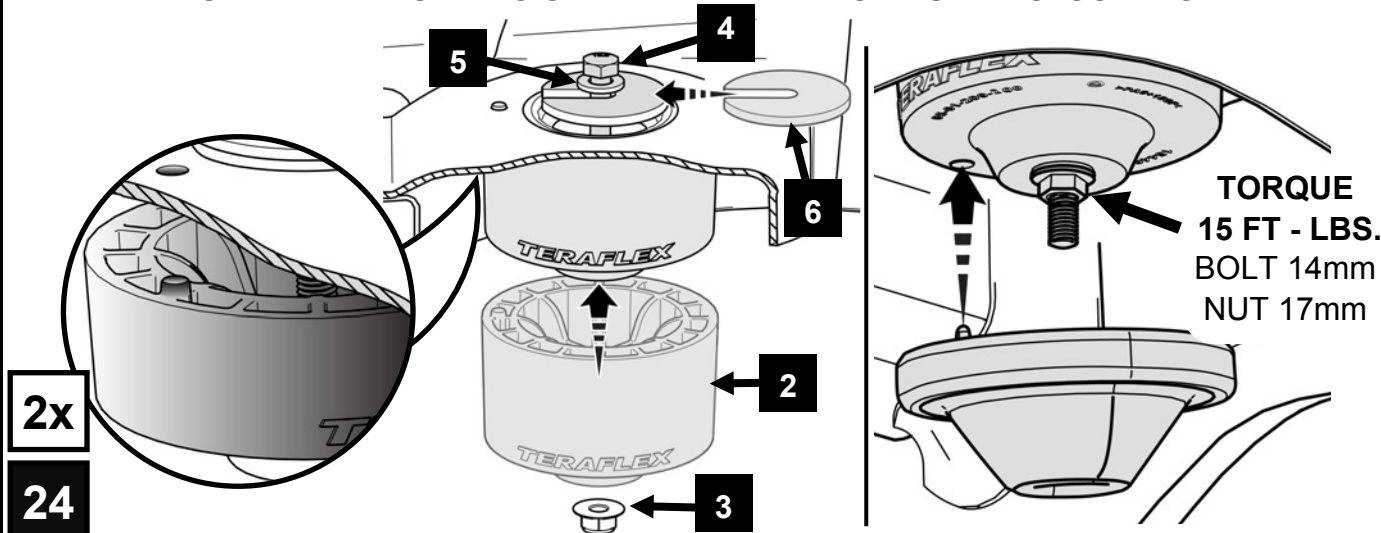

### REINSTALL REAR SPRINGS

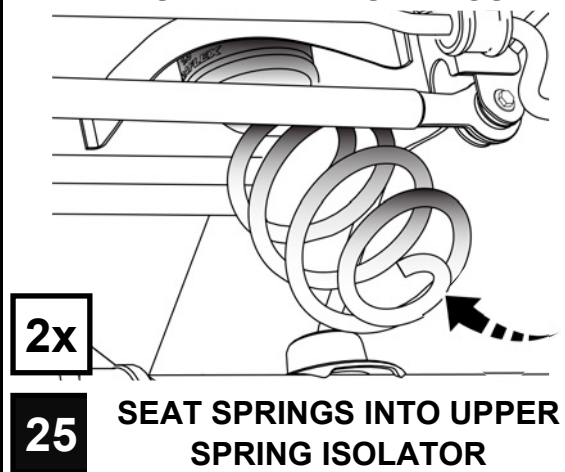

### RAISE AXLE & INSTALL SHOCKS

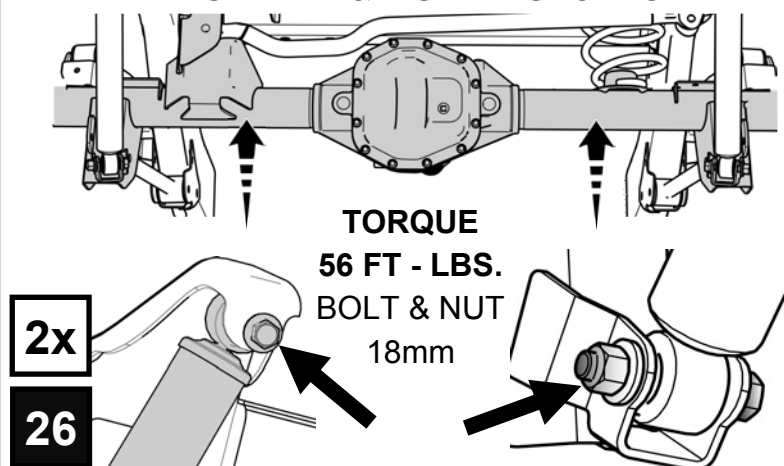

### REINSTALL BRAKE LINE BRACKETS RECONNECT PLASTIC RETAINERS FROM WIRING OR HOSES AS NEEDED

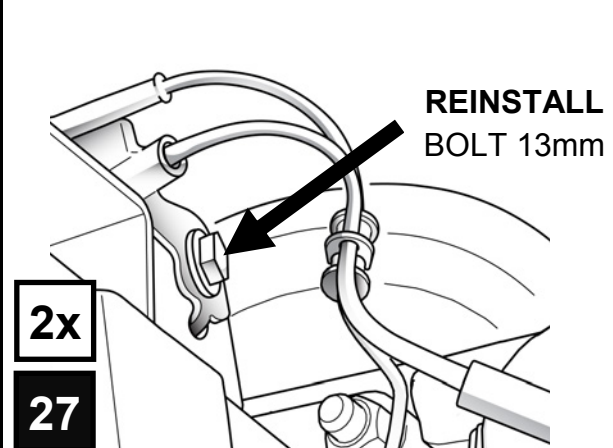

### REINSTALL SWAY BAR LINKS TO AXLE

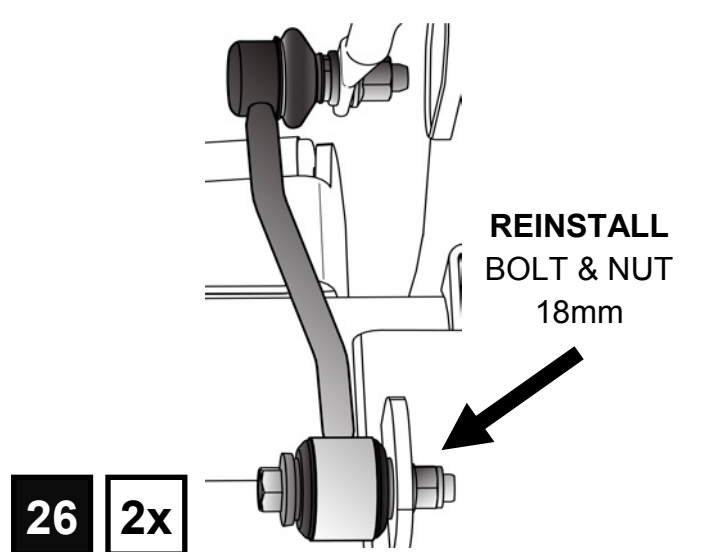

**REINSTALL TIRES AND WHEELS AND LOWER JEEP TO GROUND**  
**NOTE: DO NOT TIGHTEN THE CONTROL ARM BOLTS UNTIL THE JEEP IS ON THE GROUND**

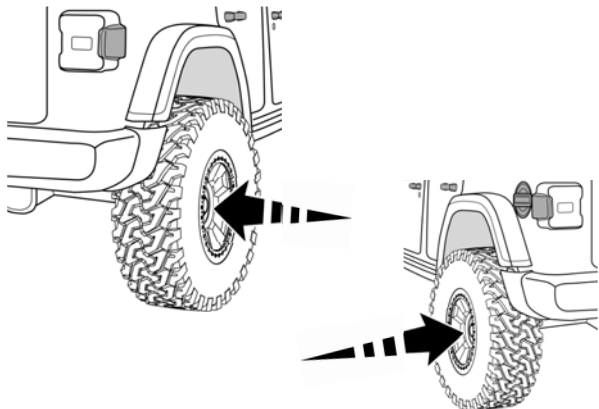

**TORQUE TO FACTORY SPEC**

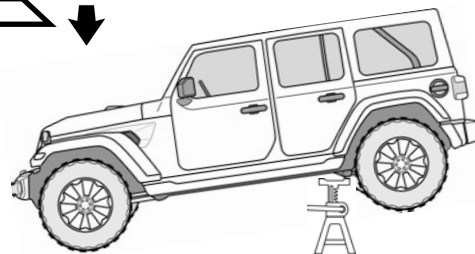
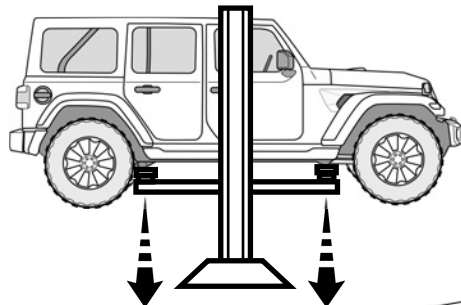

**28**

**REINSTALL TRACK BARS AND TORQUE TO FACTORY SPECS**

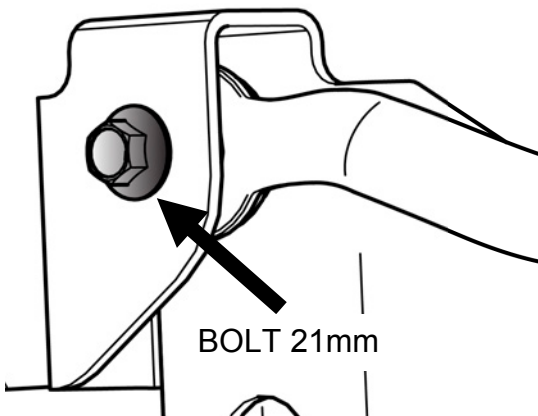

BOLT 21mm

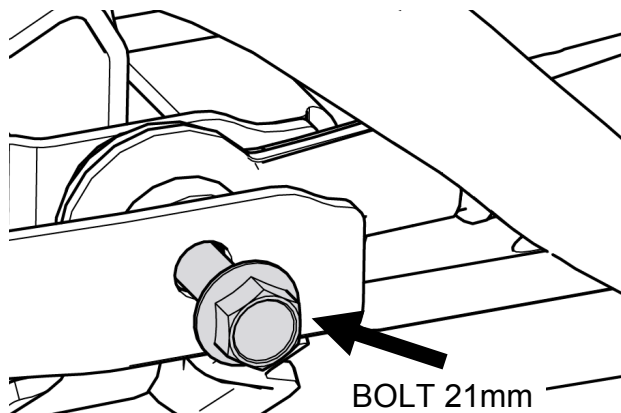

BOLT 21mm

**29**

**TORQUE FRONT AND REAR CONTROL ARM BOLTS TO FACTORY SPECS**

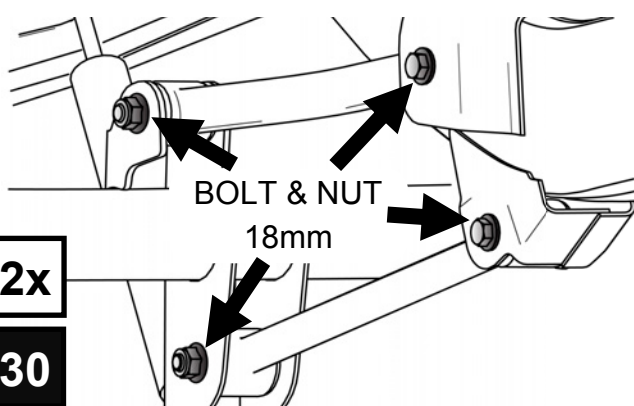

BOLT & NUT  
18mm

**2x**

**30**

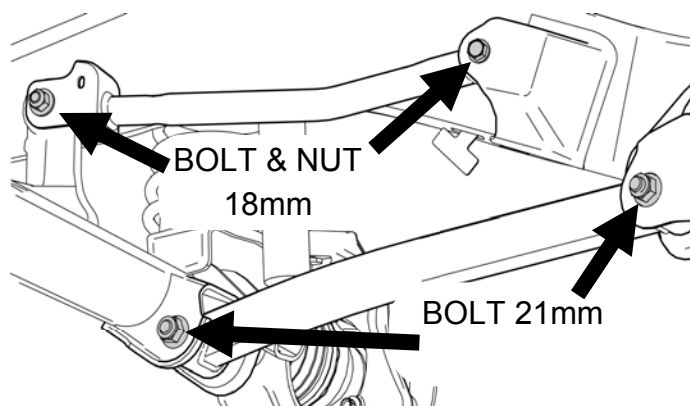

BOLT & NUT  
18mm

BOLT 21mm