

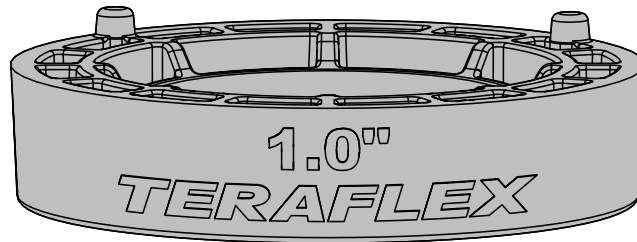

Jeep JL/JT 1" Front Load Level Kit

1155100

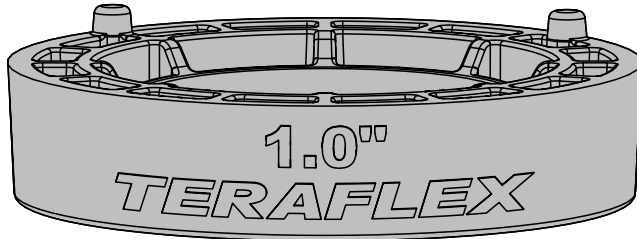

Item #	Part No.	Description	QTY
1	05-01-109-100	Spring Mount, Spacer, Front / 18-Current Jeep JL Wrangler, 1.0" Lift Height	2

Important Notes:

Prior to beginning this install, or any installation, read the instructions thoroughly to familiarize yourself with the required steps. Evaluate if you are experienced and capable to personally perform these modifications. A factory service manual should be used in conjunction with these installation instructions.

This product will change the highway handling characteristics of your vehicle, exercise caution. After altering the suspension it is always advisable to have an alignment done by a competent 4 wheel drive shop or by an alignment shop that is experienced with lifted 4 wheel drive vehicles.

Refer to the parts list to ensure that all necessary components and hardware has been included. If any parts are missing please contact your local TeraFlex dealer for assistance.

When reinstalling OEM hardware, refer to the torque specs given in the Factory Service Manual.

Tools Needed:

- Metric Sockets and Open End Wrenches
- Torque Wrench
- Factory Service Manual
- General Mechanics Tools

Maintenance Note:

After the first 300 miles and every 3,000 miles after that, re-torque all the suspension components and bolts.

LIFT JEEP AND SUPPORT AT THE FRAME

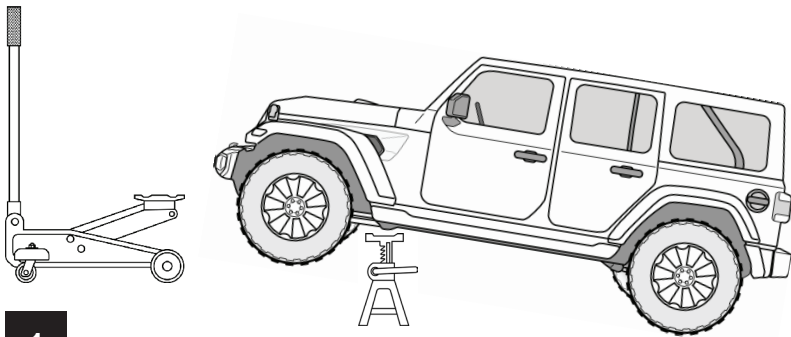

1

REMOVE FRONT WHEELS

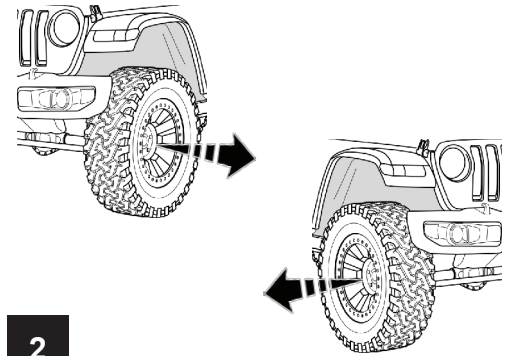

2

SUPPORT FRONT AXLE

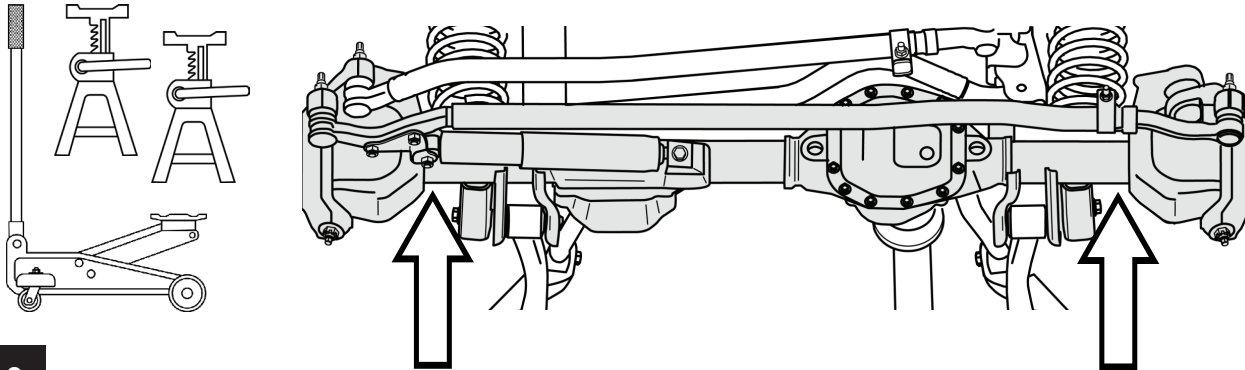

3

REMOVE SWAY BAR LINKS & TRACK BAR BOLTS AT THE AXLE

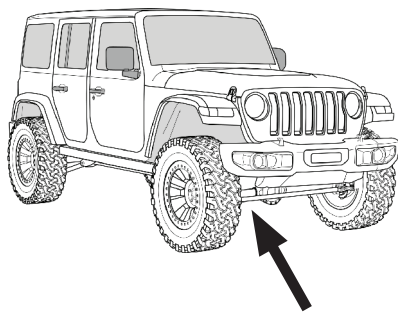

REMOVE
BOLT 18mm

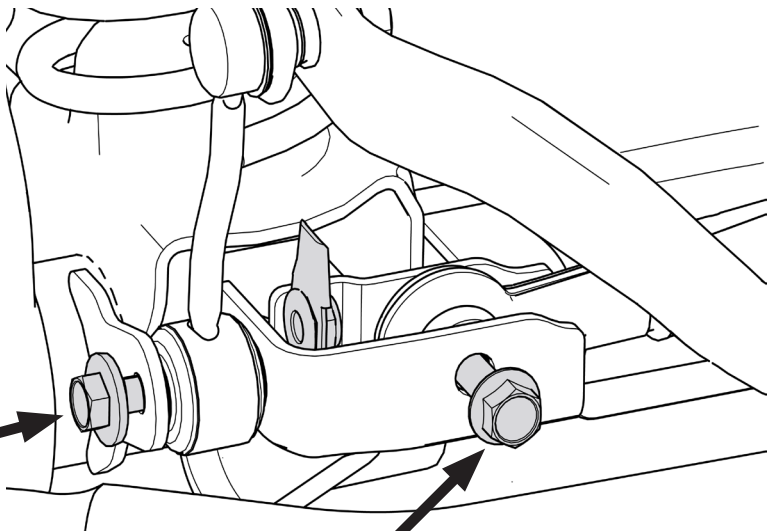

REMOVE
BOLT 18mm

4

REMOVE BRAKE LINE BRACKETS FROM LOWER CONTROL ARMS

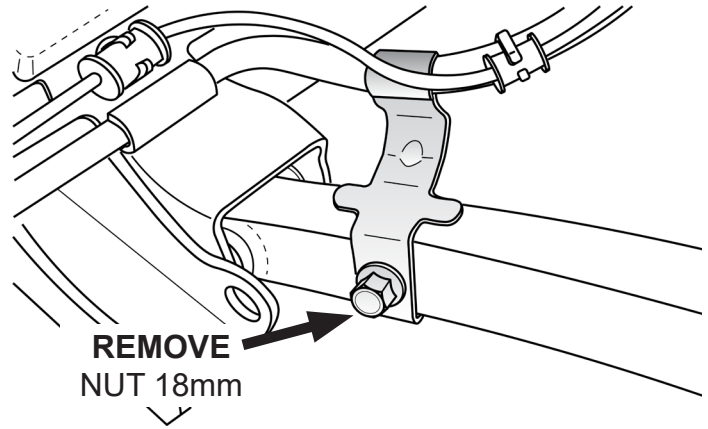
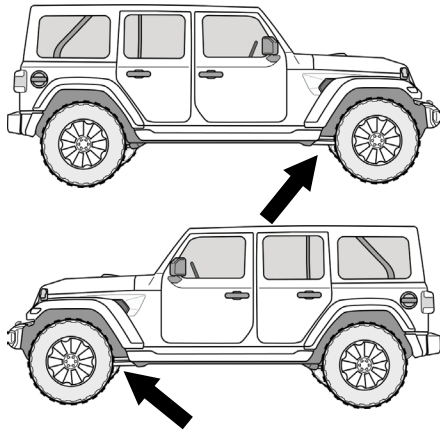

2X
5

DISCONNECT ACTUATORS & VENT HOSE AT THE FRONT AXLE

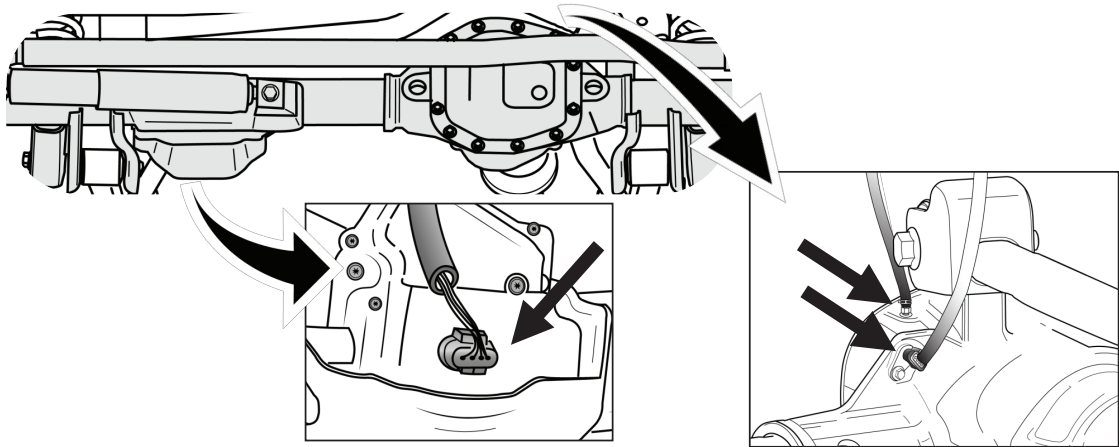

6

LOOSEN FRONT CONTROL ARM BOLTS DO NOT REMOVE THE CONTROL ARM BOLTS

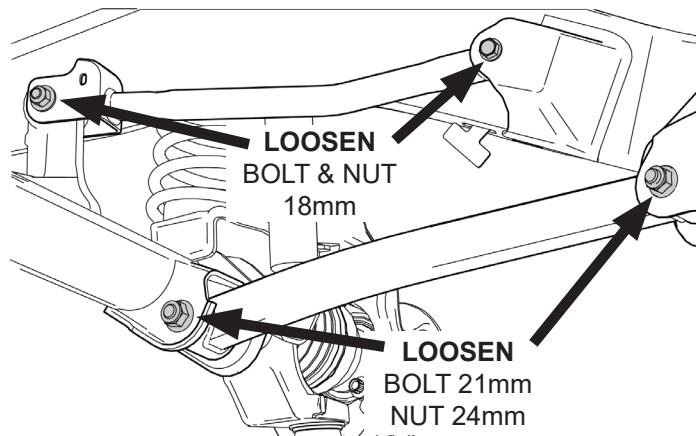
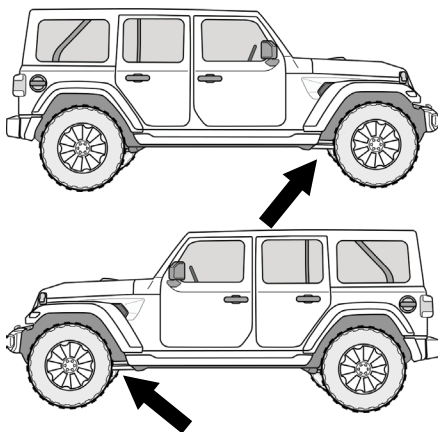

2X
7

REMOVE SHOCKS AT THE AXLE

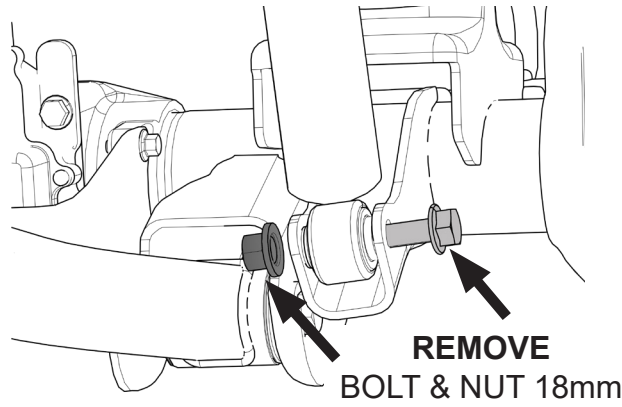

2X

8

LOWER AXLE & REMOVE FRONT SPRINGS.

NOTE: REMOVE ANY PLASTIC RETAINERS FROM WIRING OR HOSES AS NEEDED.

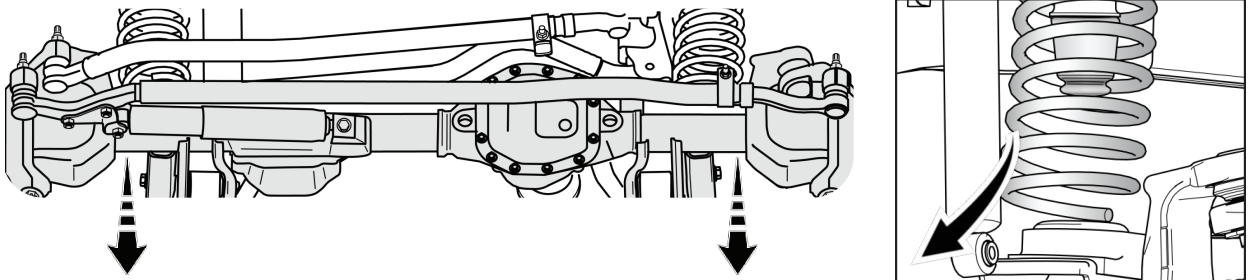

9

INSTALL FRONT SPRING SPACERS

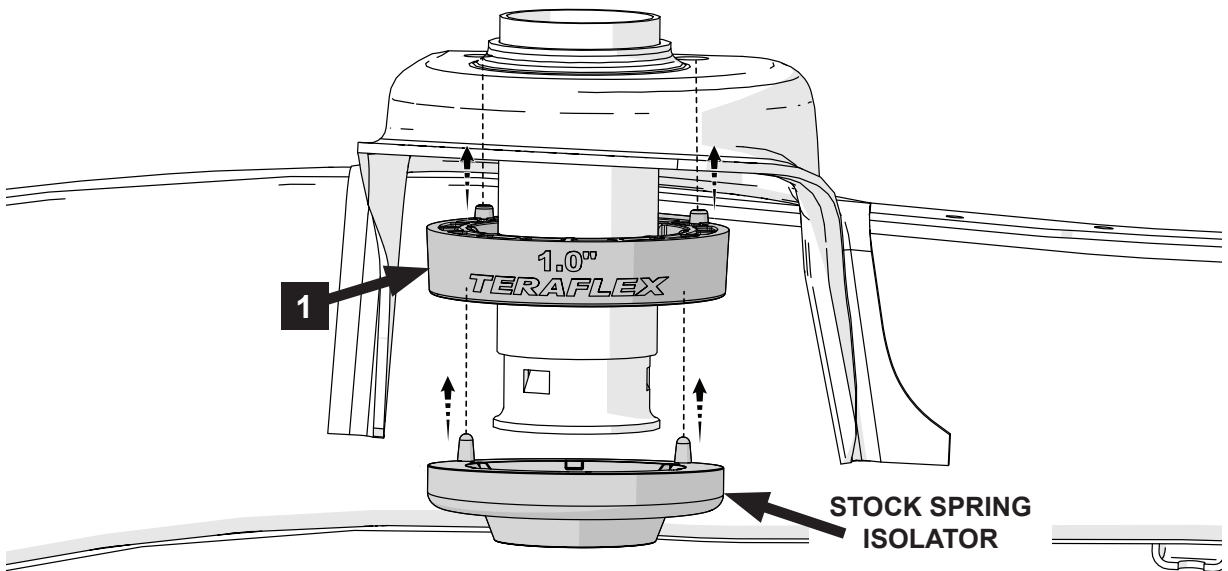

2X

10

**REINSTALL FRONT SPRINGS.
*DRIVERS SIDE FIRST***

2X

11

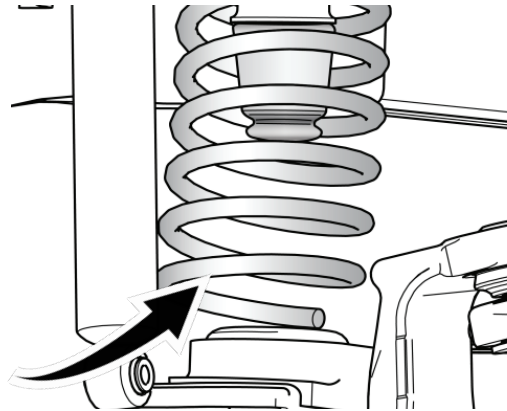

FULLY SEAT THE SPRINGS INTO THE LOWER SPRING ISOLATOR.

2X

12

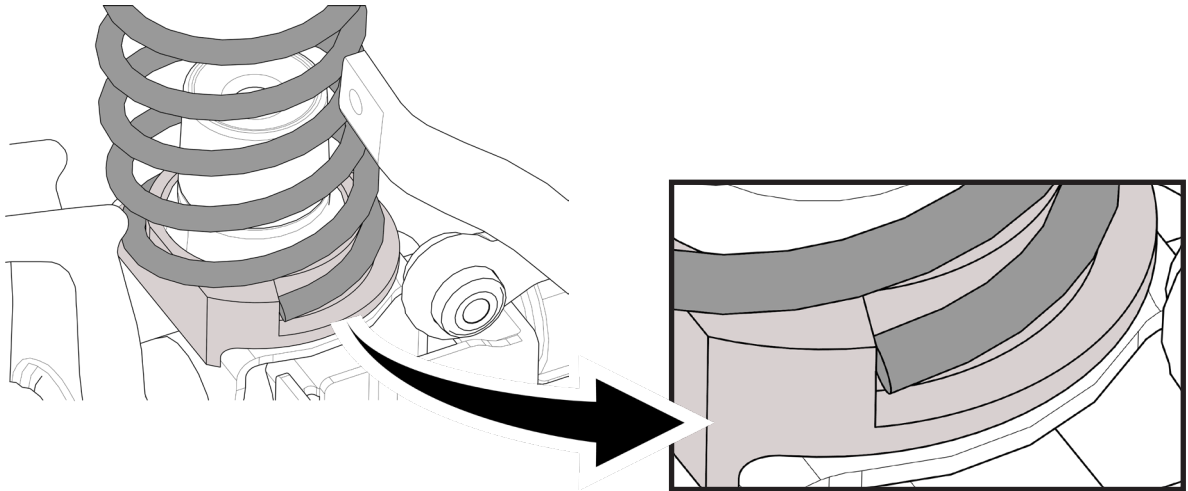

RAISE AXLE & INSTALL SHOCKS.

2X

13

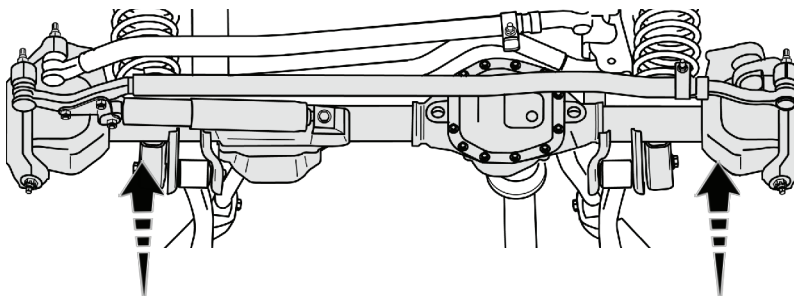

**TORQUE
BOLT & NUT 18mm
74 Ft Lbs**

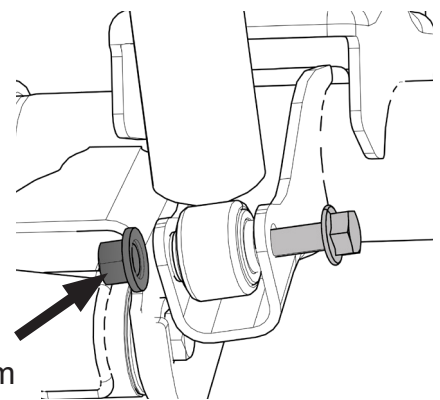

REINSTALL SWAY BAR LINK AT AXLE

TORQUE
BOLT 18mm
59 ft lbs

2X

14

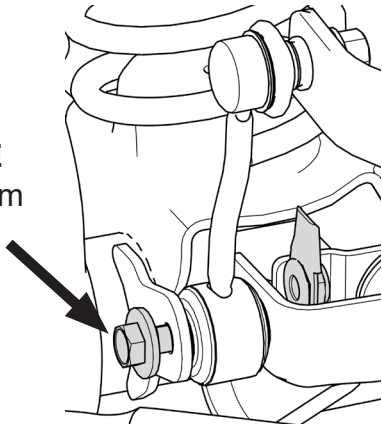

REINSTALL ANY REMAINING CONNECTORS

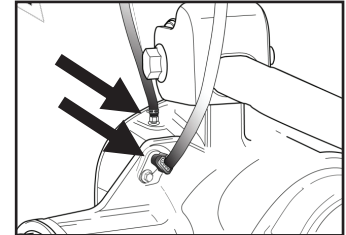
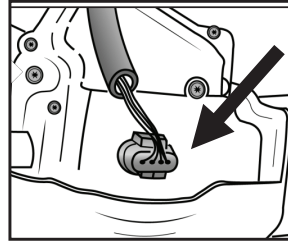

15

REINSTALL WHEELS AND LOWER JEEP BACK TO THE GROUND

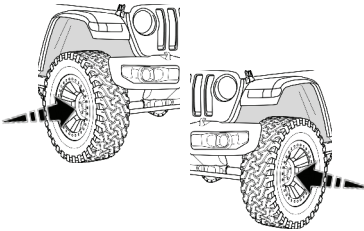

TORQUE
LUG NUTS
130 Ft Lbs

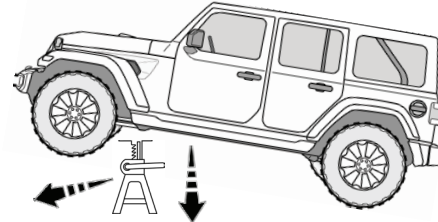

16

REINSTALL TRACK BAR

TORQUE
BOLT 21mm
52 Ft Lbs + 155°
(REF: 230-250 Ft Lbs)

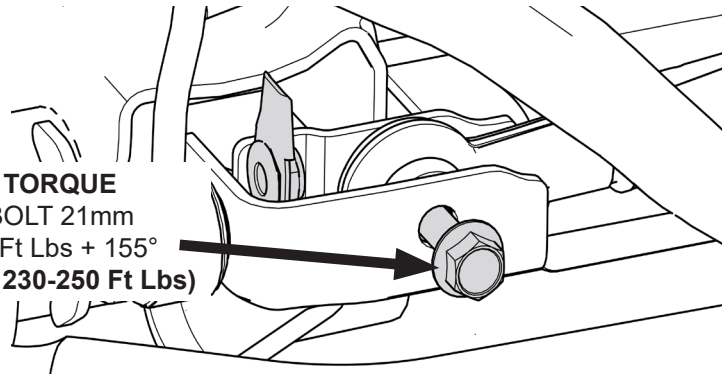

17

TORQUE FRONT CONTROL ARM BOLTS

TORQUE 18mm
41Ft Lbs + 185°
(REF: 140-160 Ft Lbs)

TORQUE 18mm
37 Ft Lbs +135°
(REF: 230-250 Ft Lbs)

TORQUE
103 Ft Lbs +145°
(REF: 230-250 Ft Lbs)
BOLT 21mm
NUT 24mm

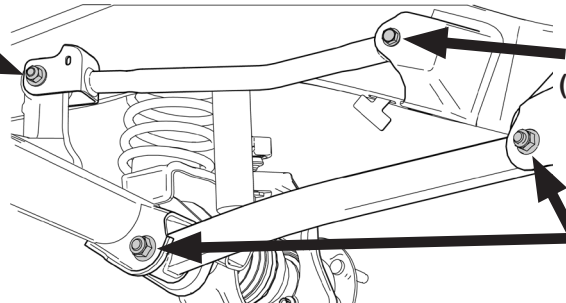

18