



## TJ 2" Lift Kit Instructions

Kit #1241200 (w/ Shocks)  
Kit #1141200 (w/o Shocks)



### Important Notes:

Prior to beginning this or any installation read these instructions to familiarize yourself with the required steps and evaluate if you are experienced and capable to personally perform these modifications. A factory service manual should be used in conjunction with these installation instructions.

This product will change the handling characteristics of your vehicle, drive with caution. A full four-wheel alignment is required after the installation of this product. We recommend your local, ASE Certified mechanic.

Refer to the parts list to ensure that all necessary components and hardware has been included. If any parts are missing please contact your local TeraFlex dealer for assistance.



### Boxes Received

Spring Box	
Springs	2 Front; 2 Rear
Rear Sway Bar Links	2
Bumpstop Extensions	2 Front; 2 Rear
Rear Track Bar Bracket	1
Hardware Bag	2

Shock Box (Kit #1241200 Only)	
Shocks	2 Front; 2 Rear

Carefully check this list prior to beginning the installation. If any parts are missing please contact your local Teraflex dealer for assistance. See installation instructions for more detailed parts lists.



## TJ 2" Suspension Lift Kit Master Installation Check-List

- Remove the Front Track Bar (See: Page 4)
- Disconnect Front Sway Bar Links (See: 999127 Quick Disconnects/Removal)
- Remove Front Shocks (See: 999188 Shocks/Front Removal)
- Remove Front Springs (See: 999187 Springs/Front Removal)
- Install Front Bumpstop Extensions (See: 999192 Bumpstop Extensions/Rear/Installation Follow the rear installation instructions for the front install)
- Install New Front Springs (See: 999187 Springs/Front Installation)
- Install Front New or Existing Shocks (See: 999188 Shocks/Front Installation)
- Drill and Reconnect the Front Track Bar (See: Page 4)
- Reconnect the Front Sway Bar Links (See: 999127 Quick Disconnects/Installation)
- Remove Rear Track Bar (See: 999195 Rear Track Bar Bracket/Removal)
- Remove Rear Sway Bar Links (See: 999191 Rear Sway Bar Link/Removal)
- Remove Rear Shocks (See: 999188 Shocks Rear Removal)
- Remove Rear Springs (See: 999187 Springs/Rear Removal)
- Install Rear Bumpstop Extensions (See: 999192 Rear/Installation)
- Install New Rear Springs (See: 999187 Springs/Rear Installation)
- Install New or Existing Rear Shocks (See: 999188 Shocks/Rear Installation)
- Install Rear Track Bar Bracket (See: 999195 Rear Track Bar Bracket/Installation)
- Reconnect the Rear Sway Bar Links (See: 999191 Rear Sway Bar Links/Installation)

## REMOVAL

This install can be performed with the vehicle sitting on the ground. Make sure it is safely support-

1

Remove from the axle bracket with either a T50 torx or a 17mm.

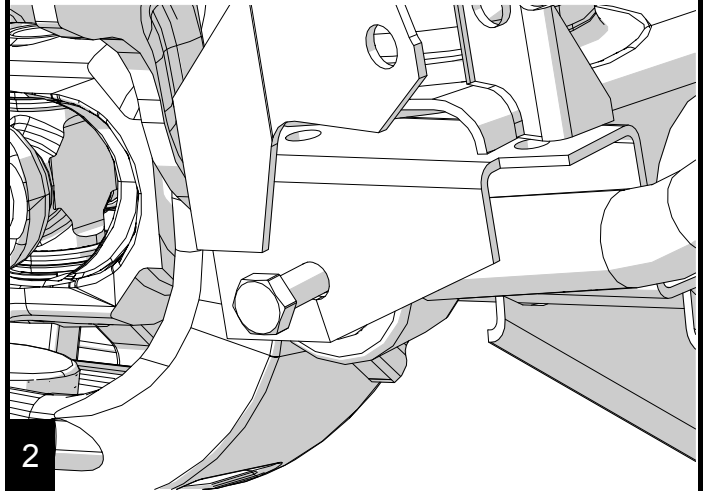

2

## INSTALLATION

With the steering wheel centered, bounce the Jeep up and down. Use the bumper for this. Without moving any other components, raise the end of the track bar up into its mounting bracket.

If you have room in the bracket so the hole does not overlap, go ahead and drill a hole with a 13/32" drill bit. If you drilled in the correct location the bar should line up with the new hole.

3

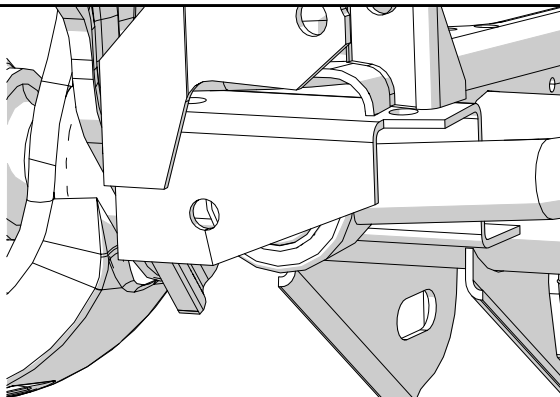

4

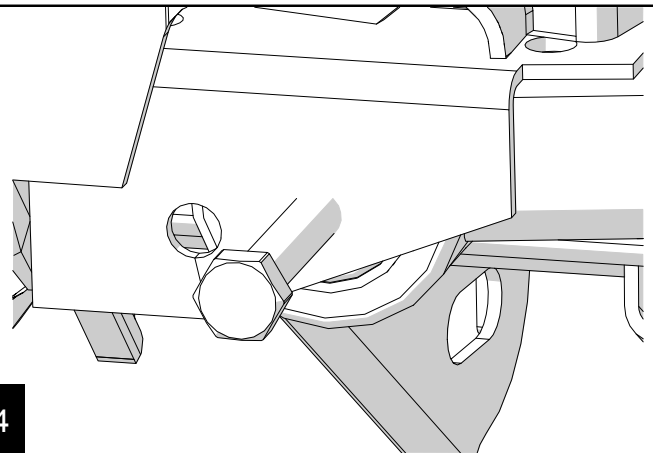

Insert the new 10mm x 75mm bolt. Torque to 40 ft-lbs.

5

