

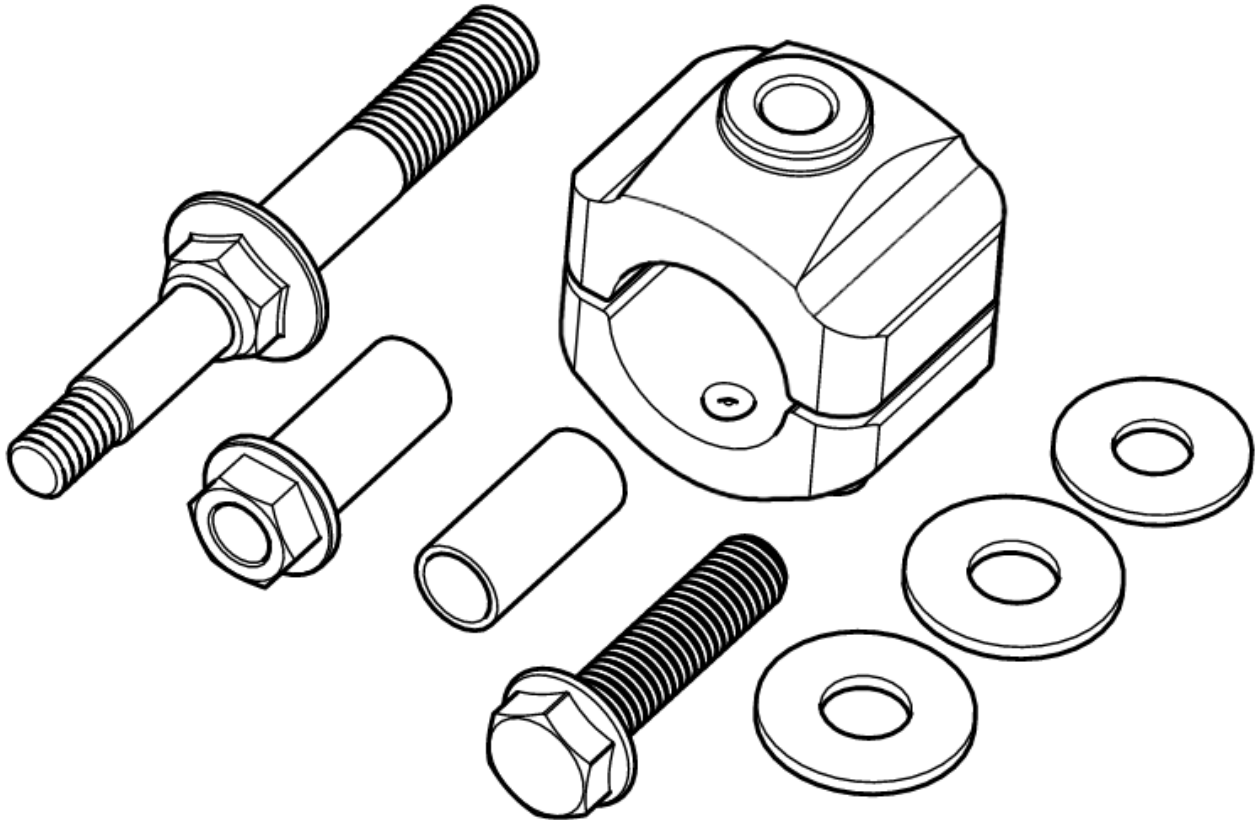

JK Steering Stabilizer Relocation Kit (for Stock Tie Rod)

Kit #1123140



Important Notes:

Prior to beginning this or any installation read these instructions to familiarize yourself with the required steps and evaluate if you are experienced and capable to personally perform these modifications. A factory service manual should be used in conjunction with these installation instructions.

Refer to the parts list to ensure that all necessary components and hardware has been included. If any parts are missing please contact your local TeraFlex dealer for assistance.

Tools needed:

- This installation guide
- Jack
- Jack Stands
- Basic mechanics tool set
- Pry Bar
- Blue LocTite
- Tape Measure

Bill of Materials for 1123140

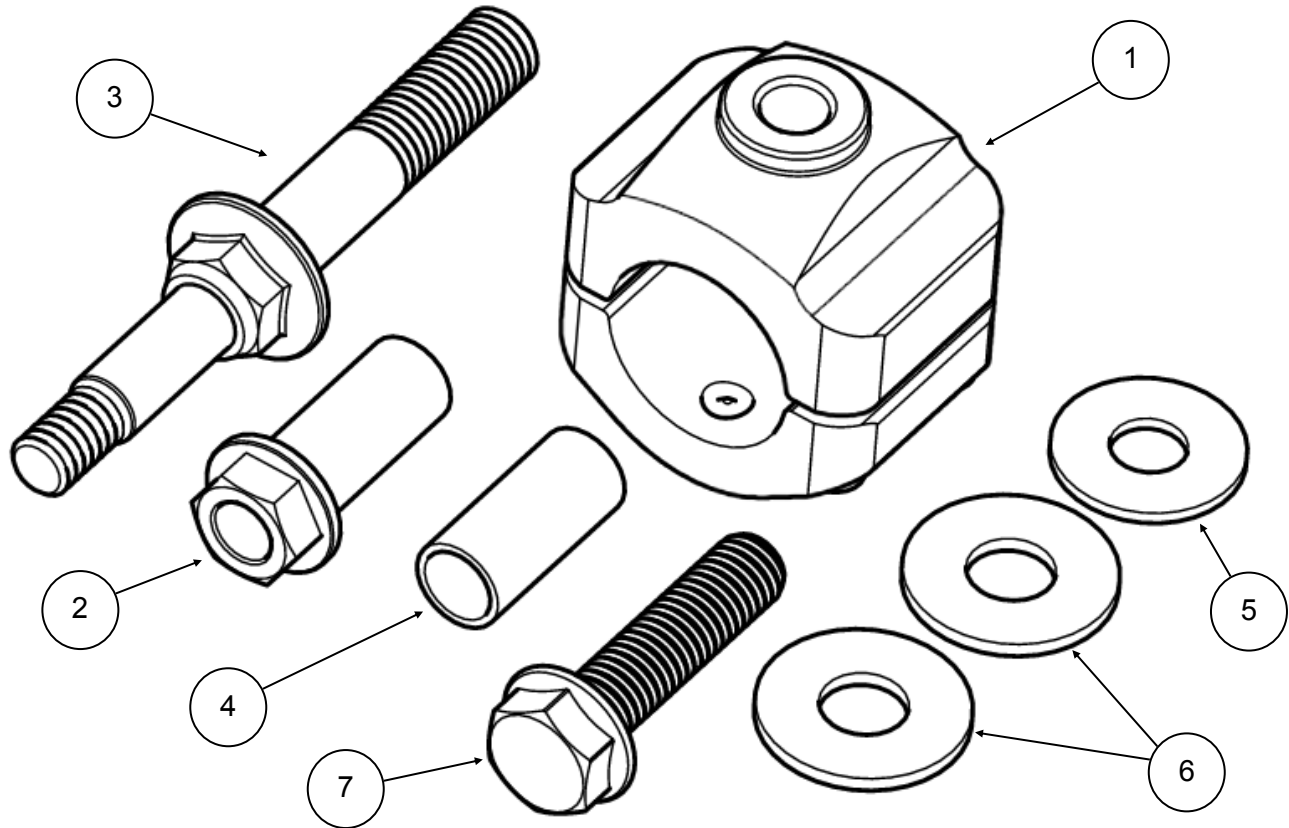

ITEM NO.	PART NUMBER	DESCRIPTION	QTY.
1	123199	Tie Rod Clamp for Steering Stabilizer 35mm (stock) Tube	1
2	513002	JK Track Bar Steering Stabilizer Relocation Stud Sleeve Nut	1
3	980882	JK Track Bar Bolt/Steering Stabilizer Relocation Mounting Stud	1
4	62148	Sleeve for Steering Stabilizer Bushings (13mm Bore)	1
5	134	Washer 7/16" Flat Zinc Plated	1
6	37	Washer 1/2" Flat Zinc Plated	2
7	267	Bolt 1/2"-20 UNC x 2-1/4" Hex Head, Zinc Plated, Medium-Strength Grade 5	1

Bill of Materials for 123199

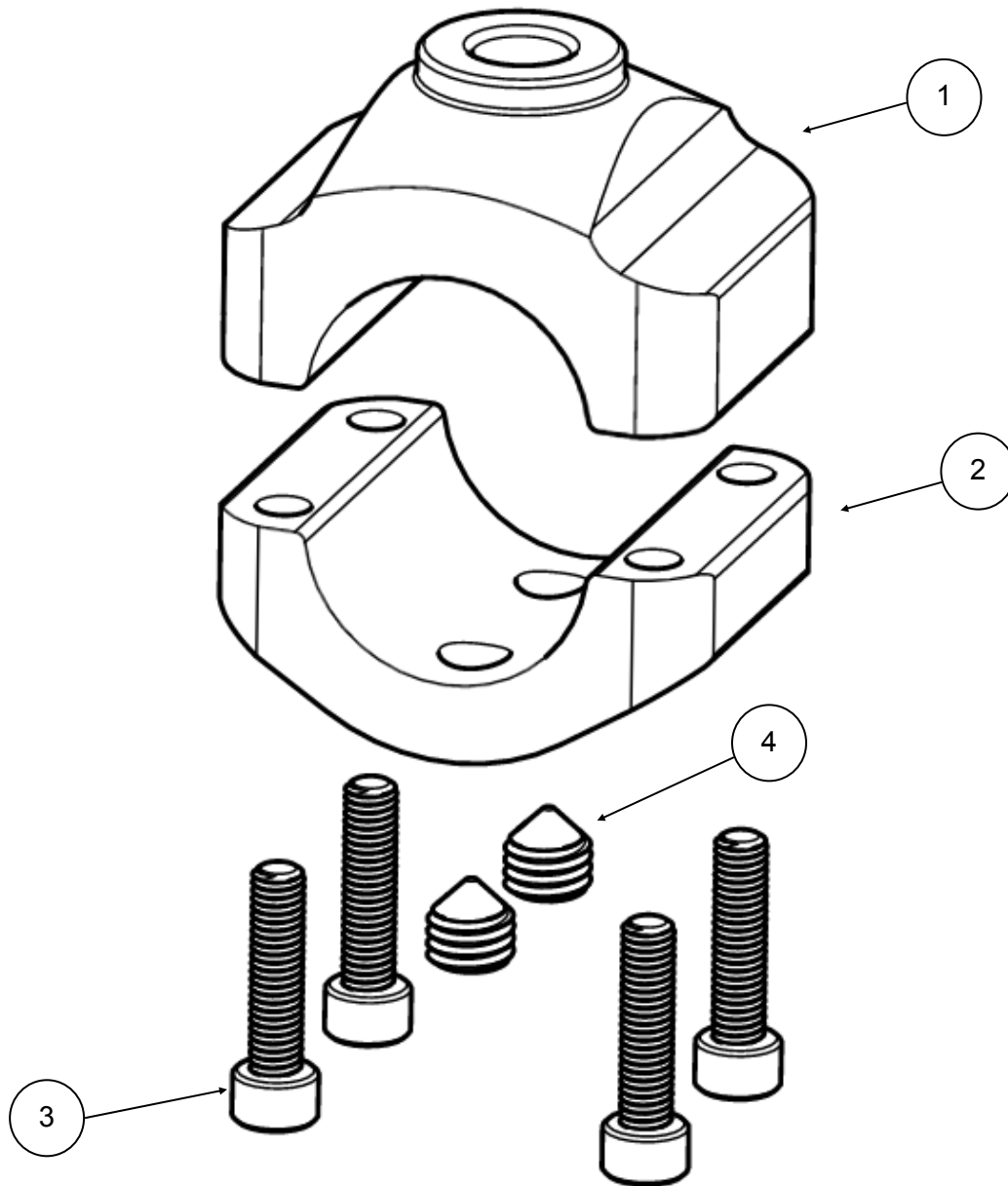

ITEM NO.	PART NUMBER	DESCRIPTION	QTY.
1	23-03-02-003	Mounting Hardware (S), Clamp, Tie Rod, 1-3/8" Tube / Top / 1/2-20 Thread	1
2	23-03-01-002	Mounting Hardware (S), Clamp, Through Shaft, 35MM Tube / Bottom	1
3	52-02-01-001	Fastener (S), Socket Head Cap Screw, Stainless, M6 X 1 / 25 mm Long	4
4	52-01-01-002	Fastener (S), Set Screw, Stainless, Cone Point / M10 X 1.5 / 10mm Long	2

Start your install with safety in mind. Begin by chocking your rear tires. Raise the front of the Jeep so that the tires are off the ground and support at the axle. (This will help with track bar bolt alignment)

1

Use an 18mm to remove the steering stabilizer.

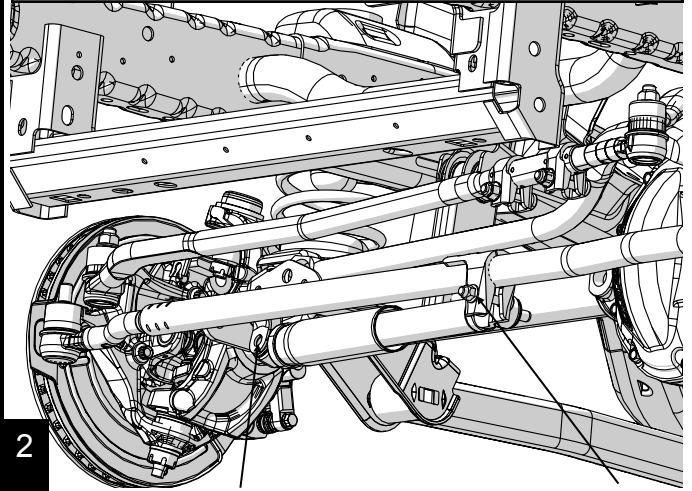

2

Remove the bolt and nut from the factory steering stabilizer tie rod clamp using a 15mm.

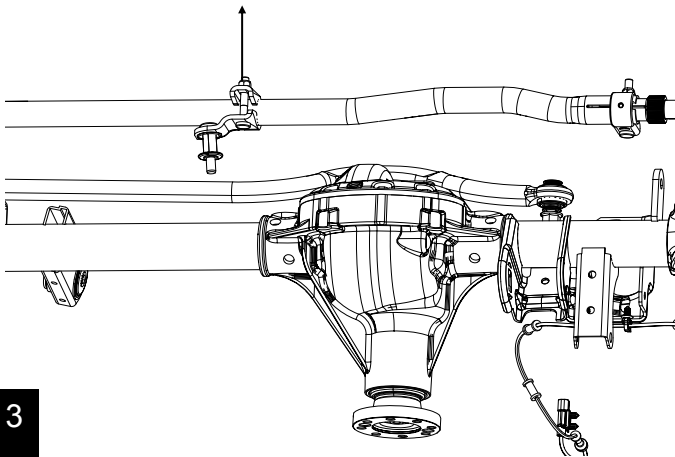

3

Use a large pry bar to pry open the factory stabilizer tie rod mount and remove the mount from the tie rod.

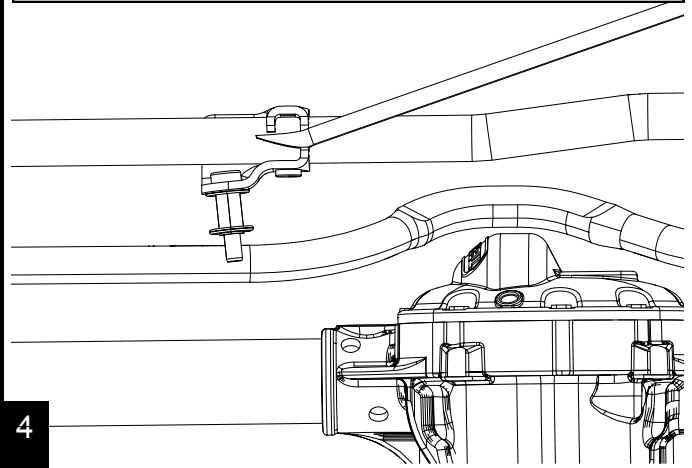

4

Hint: Slide the stabilizer mount over to the track bar bracket and rotate it until the stud contacts the bottom of the track bar bracket. This will provide a good location to pry on the stabilizer bracket. After prying, slide the bracket to the passenger side of the tie rod. The smaller diameter of the tie rod end will aid in removing the stabilizer mount.

5

With a 21mm, remove the axle side track bar bolt. Replace the bolt with the provided track bar bolt/steering stabilizer stud(980882). Use the factory nut and torque to 125 ft-lbs.

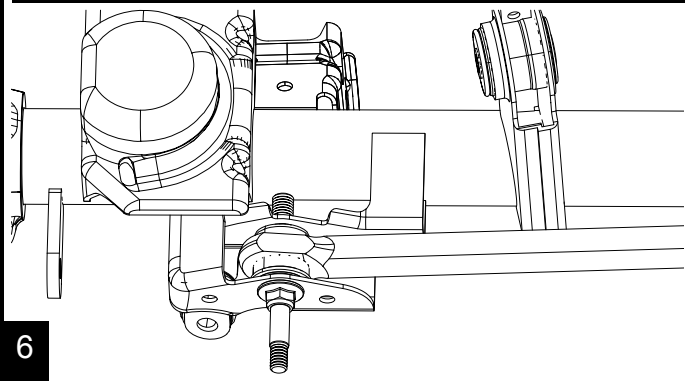

6

Remove both metal sleeves from the steering stabilizer. Install the supplied 1/2" sleeve (61248) into the piston side of the stabilizer.

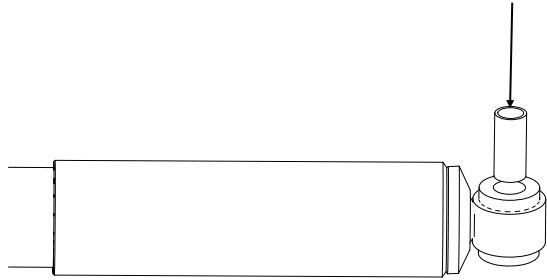

7

Place the 7/6" Washer on to the new track bar stud.

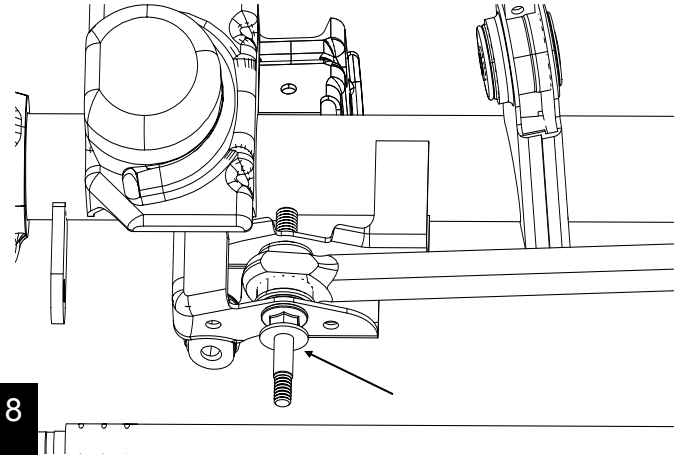

8

Install the body end of the stabilizer onto the stud and install the sleeve nut through the stabilizer eye. Loosely tighten

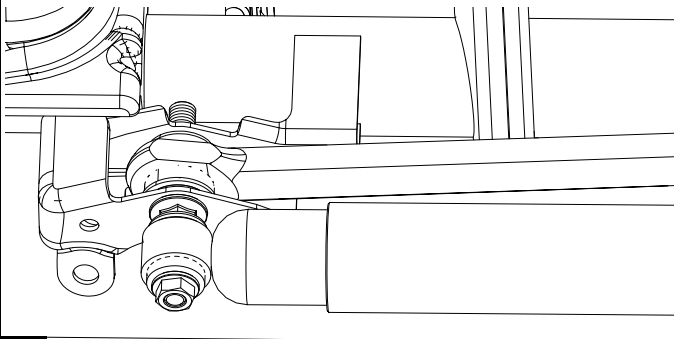

9

Make sure the tires are straight, then manually collapse the steering stabilizer to its centered position. Hint, use a tape measure. Make a mark on the tie rod where the stabilizer eyelet aligns with the tie rod.

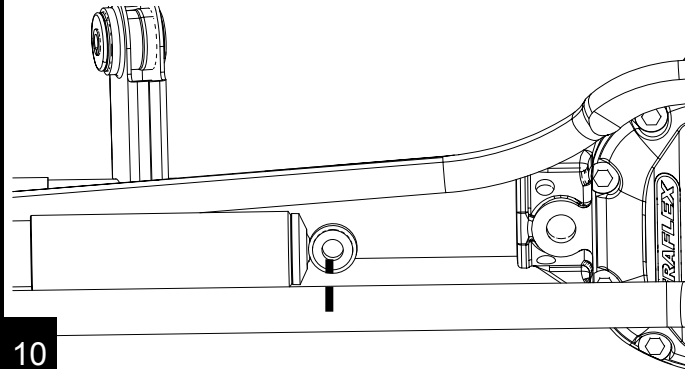

10

Apply Blue Loctite to the threads of the M6 Socket Head Cap Screws. Loosely install the clamp, centering it on the mark you just made. Lightly snug in a cross pattern the 4 clamp bolts. Final tightening will be done in step 14

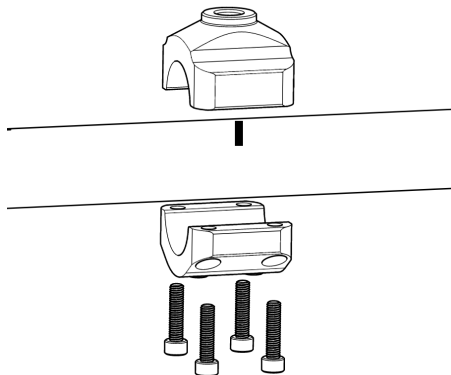

11

Use a 3/4" to install the remaining end of the stabilizer onto the top of the clamp using the 1/2" bolt and two 1/2" washers. Use Blue Loctite and Torque to 47 ft-lbs.

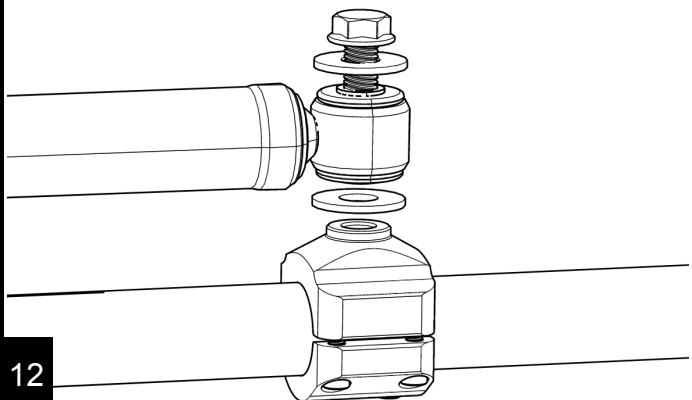

12

Use a 18mm to tighten the sleeve nut.
Torque to 47 ft-lbs

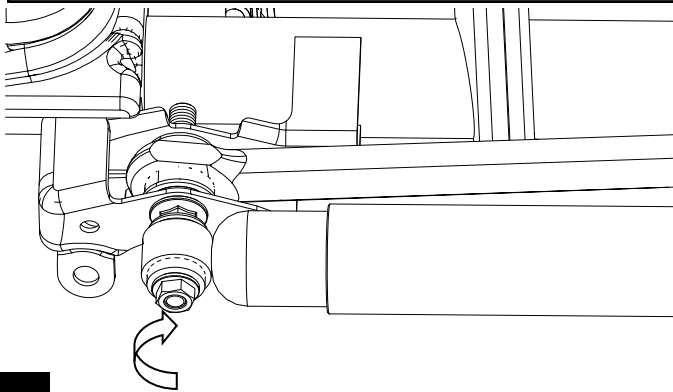

13

Have a second person SLOWLY turn the steering wheel lock to lock while you watch the stabilizer. Verify that the stabilizer clears all of the components. Once clearance and position of the clamp have been verified, use a 5mm hex bit and tighten the 4 clamp bolts, in a cross pattern, to **6 ft-lbs**. Then tighten the two set screws to **15 ft-lbs**.

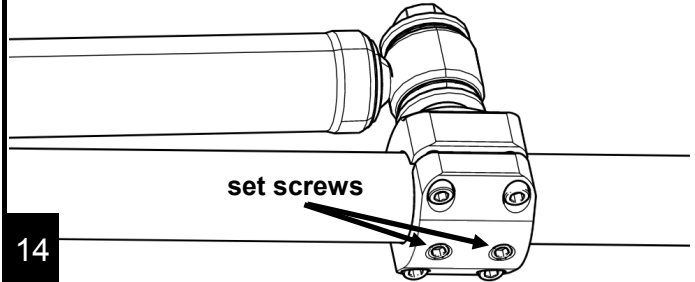

14

Congratulations! You have successfully installed your
TeraFlex Steering Stabilizer Relocation Kit.

15

PRODUCT INFORMATION

MAINTENANCE INFORMATION:

It is the buyer's responsibility to have all suspension, drivetrain, steering, and other components checked for proper tightness and torque after the first 100 miles and every 3000 miles after that.

NOTICE TO INSTALLER:

The enclosed "Warning to Driver" sticker must be installed in the vehicle in driver's view. This sticker is to act as a constant safety reminder when operating the vehicle. It is your responsibility as the equipment installer to install the provided sticker and to forward the product instructions to the vehicle's owner for review. If a "Warning to Driver" sticker or product installation guide were not included in the kit, FREE replacement stickers and instructions are available by request. It is the installer's duty to ensure a safe and controllable vehicle after the modifications have been performed.

WARNING:

Neither the seller nor the manufacturer will be liable for any loss, damage, or injury directly or indirectly arising from the use of or inability to determine the use of these products. Before using, the user shall determine the suitability of the products for its intended use, and the user shall assume all responsibility and risk in connection therewith.

WARNING TO DRIVER:

This vehicle has been modified to enhance off road performance and has unique handling characteristics. Use in harsh environments can cause extreme stress on the components. Vehicle should be inspected after being off road to make sure that all the components are in working order and safe to travel on the highway. All fasteners should be checked so that they are at the correct torque specifications as the vibration and stresses from off roading may cause critical fasteners to work loose. Extra care should be taken to inspect the critical components, steering, and brake systems. During each oil change components such as arms, tie rod ends, etc should be greased and checked for excessive wear. Any worn components should be replaced. When returning to the pavement always set or restore tire air pressure to the factory recommendation and connect or engage any disabled sway bar mechanisms. Because of the higher center of gravity and larger tires, this vehicle handles and reacts differently than many passenger cars, both on and off road. You must drive it safely! Extreme care should be taken to prevent vehicle rollover or loss of control, which can result in serious injury or death. Avoid sudden sharp turns or abrupt maneuvers. Generally, braking performance and capabilities are decreased when significantly larger/heavier tires are used, especially when used in combination with transfer case low-range reduction kits. Take this into consideration while driving. Do not add, alter or fabricate any factory or aftermarket parts to increase vehicle height over the intended height of the TeraFlex product purchased. Mixing component brand is not recommended. TeraFlex Inc. will not be responsible for any altered product or any improper installation or use of our products. We will be happy to answer any questions concerning the design, function, and correct use of our products. It is ultimately the buyer's responsibility to have all bolts/nuts checked for tightness after the first 100 miles and then every 3000 miles. Wheel alignment, steering system, suspension and drive line systems must be inspected by a qualified professional mechanic at least every 3000 miles.