



MODEL 20 One-Piece Axle Kit Instructions

Please take the time to read these instructions. A shop manual is also recommended. Please follow ALL safety precautions when working on your vehicle. The use of wheel chocks, jack stands, eye protection and proper tools is strongly recommended.

Important! Confirm you have the correct kit before disassembly. Measure from inside backing plate to centerline of differential (reference Figure A). Compare your measurements to the chart below to confirm you have the correct kit (LENGTHS ARE APPROXIMATE – HOUSINGS MAY VARY SLIGHTLY. You will find the Model 20 Kit part number on the end of your box). **THIS KIT WILL NOT WORK WITH THE POWERTRAX NO-SLIP UNIT IN A TRAC-LOCK. CALL TEN FACTORY FOR DETAILS.**

Figure A:

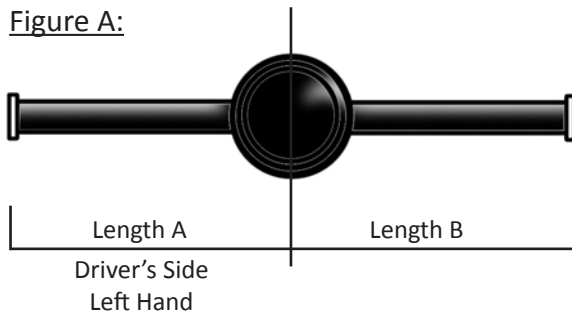

Measure your housing to be sure of the correct axle kit.		
LENGTH A	LENGTH B	KIT PART #
21-3/4"	24-3/4"	MG22125
23-15/16"	27-1/16"	MG22126

DISASSEMBLY

1. Remove differential cover. Drain oil. Please recycle used oil.
2. **Check for a "PowerLock" differential. If there are 4 spider gears, and the differential case is bolted together, it is a PowerLock. If it is a PowerLock, call TEN Factory for instructions.** A differential with a PowerLock unit requires different length axles, which may or may not be available. If there is not a PowerLock installed in your differential, continue with the installation.
3. Disconnect parking brake cables from brake assembly and backing plate. Loosen the nut on the axle until almost off. (Don't remove the nut completely yet, it will act as a stop when the hub pops off.)
4. Using the proper hub puller, carefully remove the hub and then the axle nut. Disconnect the brake line at the backing plate. Don't forget to cap or plug the brake line to avoid leaking brake fluid.
5. Remove the 4 bolts from the backing plate. Remove your Jeep's original protective guard. Remove the outer seal/retainer. Remove the backing plate. (Mark Left and Right on each side's backing plate for easier re-assembly.) Remove original shims. Save these shims. (If your housing end is out of spec, you may need these later.) Removing brake shoes makes assembly easier. (You may want to leave one side assembled for use as a reference when re-assembling.) Repeat on other side.
6. Tap on axle with a mallet to remove the opposite axle. Repeat. Remove original axles. Remove original inner seals. Discard. Clean the housing ends, original protective guards and backing plates. You are now ready to assemble. (Turn page)

Continued>



MODEL 20 One-Piece Axle Kit Instructions

Continued...

ASSEMBLY

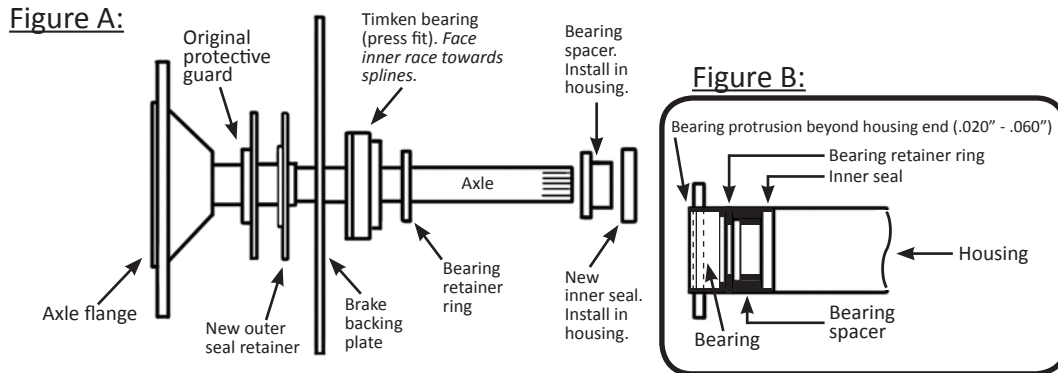

1. Install threaded wheel studs in axle flanges with supplied thread locker. Torque to 65-75 ft./lb. Install inner seal into axle housing end. Use a seal installation tool to ensure no damage to seal and seat against shoulder in housing. Apply a small amount of oil or grease on seal surface.
2. Install bearing spacer into axle housing end. (Reference Fig. B) Be sure spacer fully seats in housing. WITHOUT the axle shaft installed, test fit bearing into housing end. Be sure bearing is installed as in Figure A with the inner race facing towards the center of differential. Make sure bearing is against bearing spacer. Bearing should protrude .020" to .060" beyond housing end. (Reference Fig. B) If more than .060 extends beyond housing, remove bearing spacer, then evenly grind bearing spacer OR use original shims to "lengthen" housing end until these measurements are achieved.
3. Remove bearing for step 4. Slide the original protective guard onto axle. Passenger side axle is the longer of the two shafts. Put a small amount of oil on outer seal/retainer and slide onto axle.
4. Slide the corresponding backing plate onto the axle. Be sure brake shoe side faces the axle flange. Pack the bearing with high quality EP wheel bearing grease then press the bearing onto the axle. Be sure bearing is installed as in Fig. A with inner race facing the axle splines. Use a press suitable for axle bearings. Most auto parts stores or repair shops can press these safely. Do NOT use a hammer.
5. Press bearing retainer ring onto axle. Press tightly against bearing. Use a press suitable for axle bearings. Most auto parts stores or repair shops can press these safely. Do NOT use a hammer.
6. Apply a small amount of RTV silicone on housing end and outer seal/retainer. Slide axle assembly into housing. Align splines and gently tap into place. Align backing plate, seal/retainer and housing end holes. Install bolts and tighten.
7. Check for smooth rotation of axle with no bind. Re-assemble brakes. Install parking brake cable. Install brake line. REPEAT for other side.
8. Check brake fluid and bleed brakes. Replace differential cover. Add high quality gear oil.

You're done! Enjoy the confidence you will have knowing these axles will get you home, on or off the road.