

advanced FLOW engineering

Instruction Manual P/N: TM-2018B-R / TM-2018B-D



Make: **Lexus** Model: **RC 200t/300** Year: **2016-2019** Engine: **I4-2.0L Turbo**

Make: **Lexus** Model: **GS 200t/300** Year: **2016-2019** Engine: **I4-2.0L Turbo**

Make: **Includes F Sport models.**



- Please read the entire instruction manual before proceeding.
- Ensure all components listed are present.
- Ensure you have all necessary tools before proceeding.
- Do not attempt to work on your vehicle when the engine is hot.
- Disconnect the negative battery terminal before proceeding.
- Retain factory parts for future use.

Retain factory parts for future use.

Label	Qty.	Description	Part Number
A1	1	Air Filter (Pro DRY S)	21-91103
A2	1	Air Filter (Pro 5R)	24-91103
B	1	Tube	05-T2019B1
C	1	Housing	05-T2018B2
D	1	Coupling, Silicone Elbow	05-01466
E	2	Clamp, #044	03-50019
F	2	Screw, Torx: M4	03-50491
G	1	Clamp Mini, #024	03-50093

Installation will require the following tools:

Flat head screw driver, ratchet, 10mm socket, extension, 8mm nut driver.

Note: Legal in California for use on race vehicles only. The use of this device on vehicles used on public streets or highways is strictly prohibited in California and others states that have adopted California emission regulations.

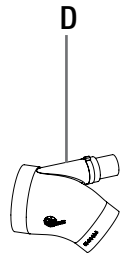
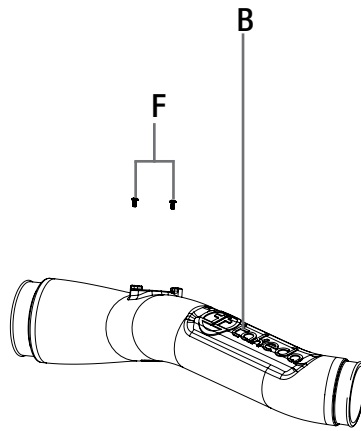
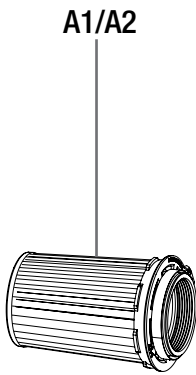
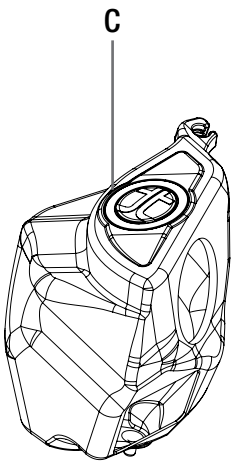



Figure A

Refer to Figure A for Steps 1-2

Step 1: Remove the engine bay cover on top of the OE airbox by taking off the plastic clips.

Step 2: Disconnect the MAF sensor harness.

**Figure B****Refer to Figure B for Steps 3-6**

Step 3: Disconnect the crank case hose off the OE intake tube.

Step 4: Remove the two 10mm bolts on the OE housing and 10mm bolt on the OE intake tube.

Step 5: Loosen the OE clamp on the turbo inlet tube.

Step 6: Remove the OE airbox and intake tube as one piece, out of vehicle.



Figure C

Refer to Figure C for Steps 7-8

Step 7: Slide the Takeda air filter into the Takeda housing, assure filter retain tabs are locked.

Step 8: Transfer the OE grommet from the OE air box onto the Takeda air box.



Figure D

Refer to Figure D for Steps 9-10

Step 9: Install coupling onto turbo inlet tube with clamps and slide the crank case hose onto the aluminum fitting, do not tighten clamps at this time.

Step 10: Install the Takeda housing and filter into the engine bay, assure the housing sits in the OE grommet and secure it using one of the OE 10mm bolt.



Figure E

Refer to Figure E for Steps 11-12

Step 11: Remove MAF sensor from OE airbox housing.

Step 12: Transfer MAF sensor into Takeda intake tube using the provided screws.



Figure F

Refer to Figure F for Steps 13-17

- Step 13: Install the Takeda tube into the vehicle. Slide the tube first into the filter then into the coupling on the throttle body.
- Step 14: Align the tube correctly then tighten all clamps.
- Step 15: Re-connect MAF harness to sensor.
- Step 16: Re-install engine bay cover.
- Step 17: Make sure all clamps and connections are secured. Your installation is now completed.

NOTE: Check all bolts, clamps and connectors after 100-200 miles.

[Learn more about other performance air intake systems by Takeda on our website.](#)