

advanced FLOW engineering

Instruction Manual P/N: TM-1026B-D / TM-1026B-R



Make: **Honda** Model: **Civic Si** Year: **2017-2019** Engine: **I4-1.5L Turbo**



- Please read the entire instruction manual before proceeding.
- Ensure all components listed are present.
- If you are missing any of the components, call customer support.
- Ensure you have all necessary tools before proceeding.
- Do not attempt to work on your vehicle when the engine is hot.
- Disconnect the negative battery terminal before proceeding.
- Retain factory parts for future use.

Retain factory parts for future use.

Label	Qty.	Description	Part Number
A1	1	Air Filter (Pro DRY S)	21-91103 (Grey Media)
A2	1	Air Filter (Pro 5R)	24-91103 (Blue Media)
B	1	Tube	05-T1024B1
C	1	Housing	05-T1026B2
D	1	Coupling, Silicone	05-01410
E	2	Clamp, #044	03-50019
F	2	Screw, Torx: M4	03-50491

Installation will require the following tools:

Flat head screw driver, ratchet, 10mm socket, extension, 8mm nut driver

Note: Legal in California for use on race vehicles only. The use of this device on vehicles used on public streets or highways is strictly prohibited in California and others states that have adopted California emission regulations.

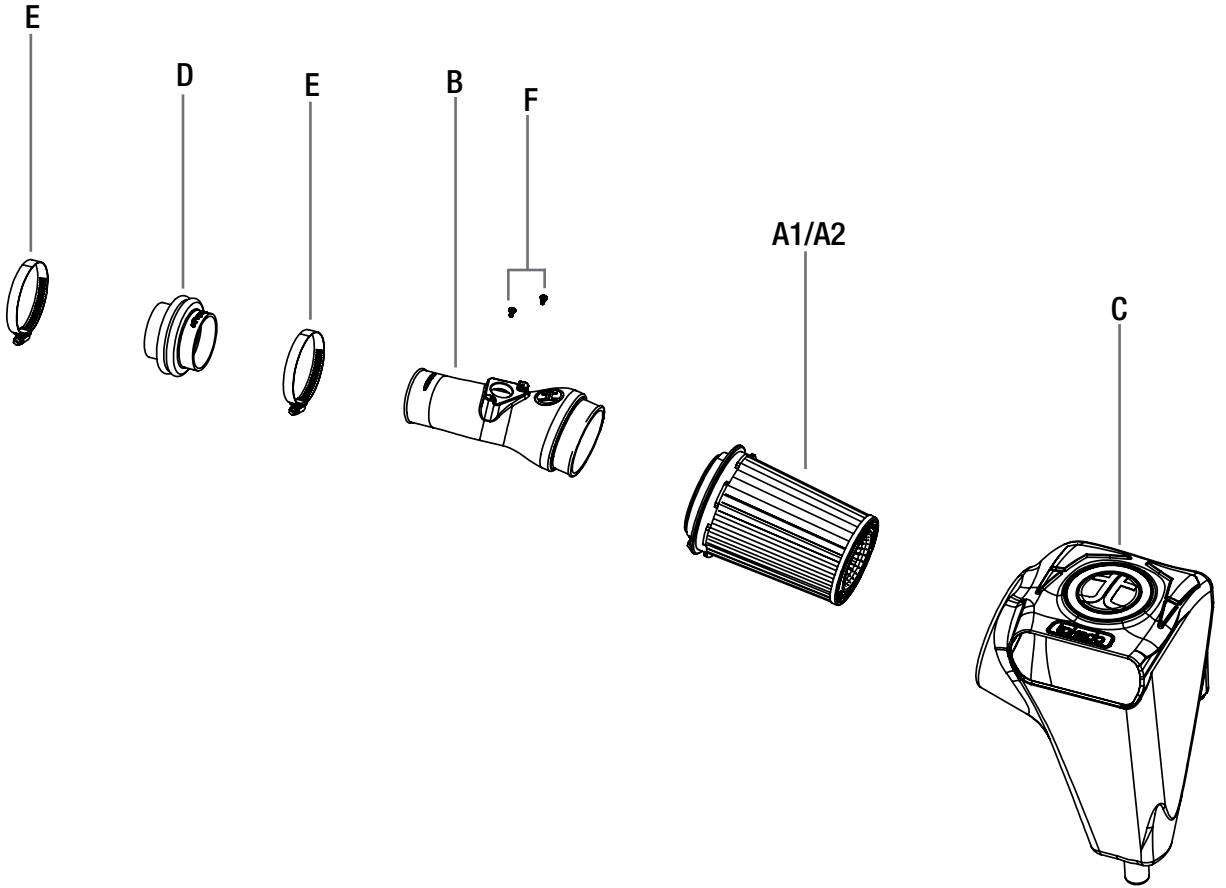

**Figure A****Refer to Figure A for Steps 1-4**

- Step 1: Disconnect the MAF sensor harness, with a small flat head screwdriver unclip the harness holder and release it from the air box.
- Step 2: Loosen the clamp on the OE intake tube connecting to the turbo inlet tube.
- Step 3: Remove the two 10mm bolts retaining the OE housing.
- Step 4: With an upward motion remove the OE intake system out of the vehicle.

INSTALL



Figure B

Refer to Figure B for Step 5

Step 5: Transfer one of the OE grommets onto the Takeda Housing with the metal insert



Figure C

Refer to Figure C for Steps 6-7

Step 6: Install the Takeda housing into the vehicle assure the OE grommet has not moved from the OE resonator.

Step 7: Secure the housing with one of the OE bolts removed previously.



Figure D

Refer to Figure D for Step 8

Step 8: Slide the Takeda air filter into the Takeda housing, assure the filter tabs are locked on the housing.



Figure E

Refer to Figure E for Steps 9-10

Step 9: Transfer the MAF sensor from the OE housing to the Takeda intake tube with the supplied screws.

Step 10: Install the reducer coupling onto the Takeda intake tube with clamps, assure the larger opening on the coupling stops on the retain hump. Tighten clamp on tube.



Figure F

Refer to Figure F for Steps 11-13

Step 11: With a small flat head screwdriver, un-clip the 4 tabs and open the wire cover.

Step 12: Re-route the wire harness to add more length.

Step 13: Close the wire cover.



Figure G

Refer to Figure G for Steps 14-16

Step 14: Slide the tube into the air filter first then onto the turbo inlet, align tube then tighten clamps.

Step 15: Re-connect MAF sensor harness.

Step 16: Make sure all clamps and connections are secured. Your installation is now completed.

NOTE: Check all bolts, clamps and connectors after 200 miles.



Pro DRY S Air Filter



P/N: 21-91103

Pro 5R Air Filter



P/N: 24-91103

Pro DRY S Restore Kit



P/N: TP-7015C

Blue Squeeze Restore Kit



P/N: 90-50501

SCORCHER GT Module



P/N: 77-46601

(Coupe) Exhaust Cat-Back



P/N: 49-36618-L (Blue Tips)
49-36618-P (Pol. Tips)
49-36618-C (C/F Tips)

(Sedan) Exhaust Cat-Back



P/N: 49-36621-L (Blue Tips)
49-36621-P (Pol. Tips)
49-36621-C (C/F Tips)

Takeda T-Shirt



P/N: 40-30332 (M)
40-30333 (L)
40-30334 (XL)