

advanced FLOW engineering

Instruction Manual P/N: TM-1025B-D / TM-1025B-R

Make: **Honda** Model: **Civic Type R** Year: **2017-2018** Engine: **I4-2.0L Turbo**



- Please read the entire instruction manual before proceeding.
- Ensure all components listed are present.
- Ensure you have all necessary tools before proceeding.
- Do not attempt to work on your vehicle when the engine is hot.
- Disconnect the negative battery terminal before proceeding.
- Retain factory parts for future use.

Retain factory parts for future use.

Label	Qty.	Description	Part Number
A1	1	Air Filter (Pro DRY S)	21-91103 (Grey Media)
A2	1	Air Filter (Pro 5R)	24-91103 (Blue Media)
B	1	Tube	05-T1025B1
C	1	Housing	05-T1025B2
D	1	Coupling, Silicone Hump	05-01455
E	2	Clamp, #044	03-50019
F	2	Screw, Torx: M4	03-50491
G	1	Torx Bit: T20	03-50066
H	1	Slit Loom (12" inches)	03-50586

Installation will require the following tools:

Flat head screw driver, ratchet, 10mm socket, extension, 8mm nut driver.

Note: Legal in California for use on race vehicles only. The use of this device on vehicles used on public streets or highways is strictly prohibited in California and others states that have adopted California emission regulations.

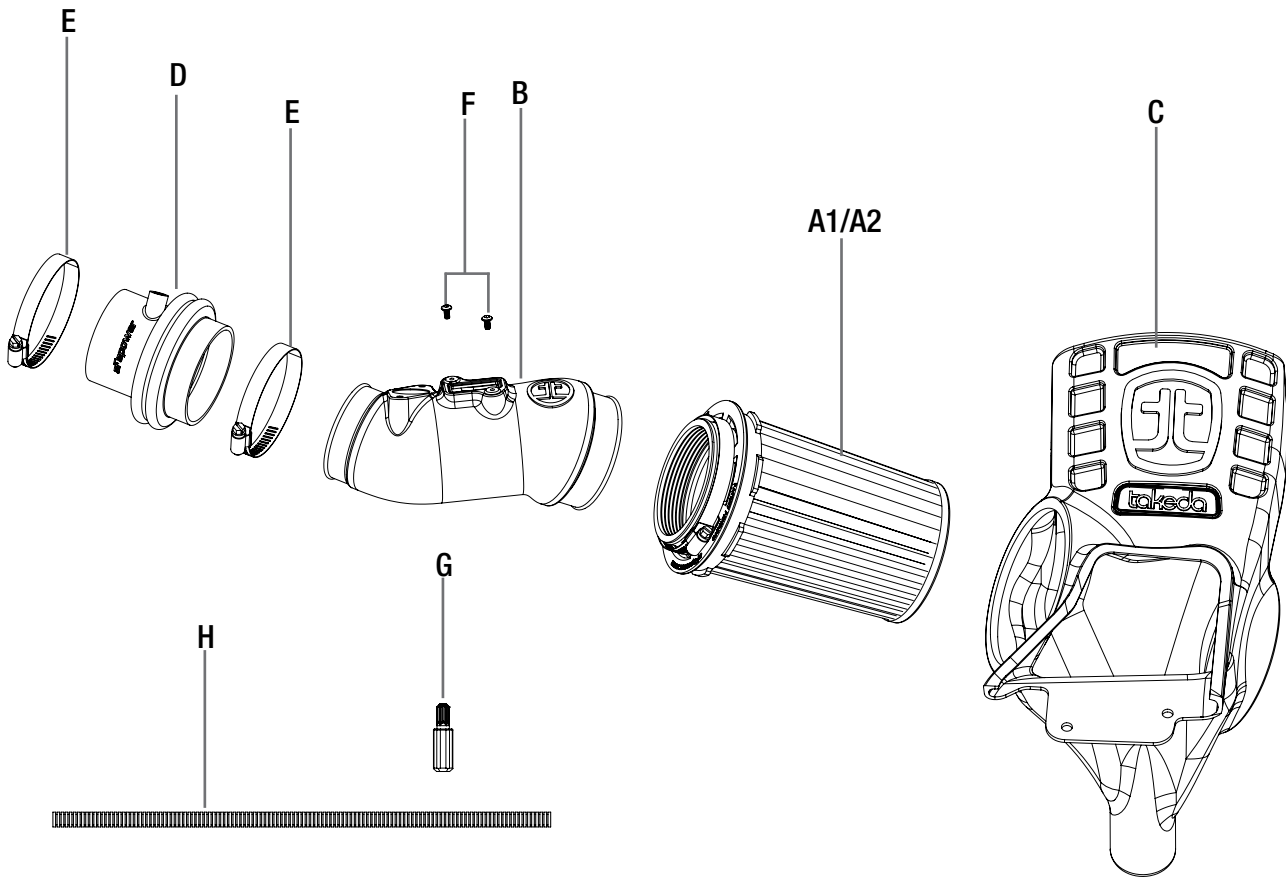



Figure A

Refer to Figure A for Step 1

Step 1: Disconnect MAF harness.



Figure B

Refer to Figure B for Steps 2-3

Step 2: Disconnect the both hose on the Purge jet.

Step 3: With an upwards motion pull off the crank case line from the stock coupling.



Figure C

Refer to Figure C for Step 4

Step 4: With A small flat head screwdriver unclip the harness holder and open to release the harness free.



Figure D

Refer to Figure D for Step 5

Step 5: Carefully remove seal trim off the stock airbox with retaining clips.



Figure F

Refer to Figure F for Steps 9-10

Step 9: Transfer one of the mounting grommet on the stock airbox to the Takeda housing.

Step 10: Transfer the stock grommet from the bottom of the airbox to the Takeda housing.

**Figure G****Refer to Figure G for Steps 11-12**

Step 11: Using a Philips screw driver remove the MAF sensor from the stock intake tube and transfer to the Takeda intake tube using the supplied torx screws.

Step 12: With a 10mm remove the purge jet off the stock intake tube and transfer to the Takeda intake tube securing it with the stock hardware.



Figure H

Refer to Figure H for Steps 13-14.

Step 13: Install the split loom over the exposed MAF wire harness.

Step 14: Install the Takeda housing into the engine bay, by locating the bottom stock grommet location.



Figure 1

Refer to Figure 1 for Steps 15-17

Step 15: Reusing the 10mm bolts in Step 7, secure the housing and discard the extra bolt.

Step 16: Install the stock trim seal on the Takeda housing.

Step 17: Insert the aFe filter into the Takeda housing, assure the locking tabs are lock on the housing.



Figure J

Refer to Figure J for Step 18

Step 18: Insert the stock crank case fitting into the supplied coupling and slide with clamps onto the turbo manifold inlet. Do not tighten clamps at this time.

**Figure K****Refer to Figure K for Steps 19-23**

Step 19: Slide the Takeda intake tube into the air filter then slide into the coupling.

Step 20: Reconnect the two hoses on the purge jet accordingly.

Step 21: Reconnect MAF sensor harness.

Step 22: Align the intake tube with the air filter and coupling. Tighten the coupling then the air filter.

Step 23: Make sure all clamps and connections are secured. Your installation is now completed.



Pro DRY S Air Filter



P/N: 21-91103

Pro 5R Air Filter



P/N: 24-91103

Pro DRY S Restore Kit



P/N: TP-7015C

Blue Squeeze Restore Kit



P/N: 90-50501

SCORCHER GT Module



P/N: 77-46601

Cat-Back Exhaust System



P/N: 49-36616-L (Blue Tips)
49-36616-P (Pol. Tips)
49-36616-C (C/F Tips)
49-36616-B (Blk. Tips)

Turbo Downpipe



P/N: 48-36606-HC (Street)
48-36606-HN (Race)

Rear Downpipe/Mid-Pipe



P/N: 49-36617

Intercooler Chargepipes



P/N: 46-20324-R

Test Pipe/Delete Pipe



P/N: 49-36622

aFe Control Lowering Springs



P/N: 410-701001-N

aFe Control Sway Bars

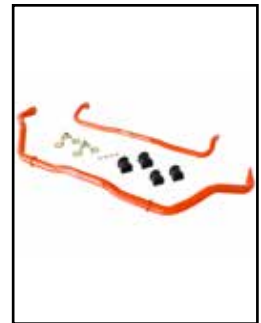

P/N: 440-701001-N